

**OPERATOR'S AND ORGANIZATIONAL
MAINTENANCE MANUAL**

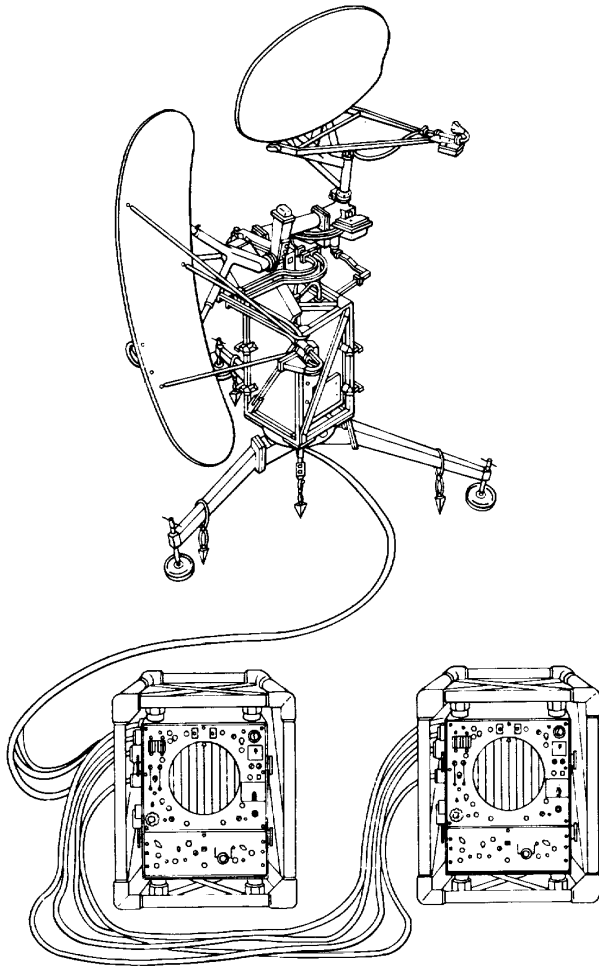

| | |
|------------------------------|--|
| OPERATOR PMCS PAGE 2-8 | |
|------------------------------|--|

| | |
|--|--|
| OPERATION UNDER USUAL CONDITIONS PAGE 2-10 | |
|--|--|

| | |
|---|--|
| OPERATOR TROUBLESHOOTING PROCEDURES PAGE 3-1 | |
|---|--|

| | |
|--|--|
| ORGANIZATIONAL (PMCS) PAGE 4-103 | |
|--|--|

| | |
|---|--|
| ORGANIZATIONAL TROUBLESHOOTING PROCEDURES PAGE 4-105 | |
|---|--|

| | |
|---|--|
| ORGANIZATIONAL MAINTENANCE PROCEDURES PAGE 4-117 | |
|---|--|

| | |
|---------------------------------------|--|
| MAINTENANCE ALLOCATION PAGE B-1 | |
|---------------------------------------|--|

**RADAR SET
ANITPN-18A (NSN 5840-01-070-9415)**

DEPARTMENT OF THE ARMY

15 JANUARY 1986



5

SAFETY STEPS TO FOLLOW IF SOMEONE IS THE VICTIM OF ELECTRICAL SHOCK

1

DO NOT TRY TO PULL OR GRAB THE INDIVIDUAL

2

IF POSSIBLE, TURN OFF THE ELECTRICAL POWER

3

IF YOU CANNOT TURN OFF THE ELECTRICAL POWER, PULL, PUSH OR LIFT THE PERSON TO SAFETY USING A DRY WOODEN POLE OR A DRY ROPE OR SOME OTHER INSULATING MATERIAL

4

SEND FOR HELP AS SOON AS POSSIBLE

5

AFTER THE INJURED PERSON IS FREE OF CONTACT WITH THE SOURCE OF ELECTRICAL SHOCK, MOVE THE PERSON A SHORT DISTANCE AWAY AND IMMEDIATELY START ARTIFICIAL RESUSCITATION

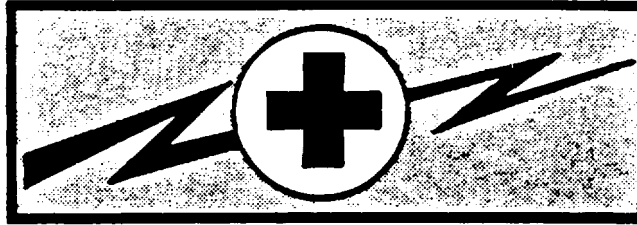
WARNING**WARNING****HIGH VOLTAGE****IS USED IN THE OPERATION OF THIS EQUIPMENT****DEATH ON CONTACT****MAY RESULT IF PERSONNEL FAIL TO OBSERVE SAFETY PRECAUTIONS**

Never work on electronic equipment unless there is another person nearby who is familiar with the operation and hazards of the equipment and who is competent in administering first aid. When the technician is aided by operators, he or she must warn them about dangerous areas.

Whenever possible, the power supply to the equipment must be shut off before beginning work on the equipment. Take particular care to ground every capacitor likely to hold a dangerous potential. When working inside the equipment, after the power has been turned off, always ground every part before touching it.

Never bypass (cheat) interlocks or ignore warning and caution labels. Remove Jewelry such as rings, watches, etc before performing maintenance tasks.

Never stand in front of idle radar antenna when transmitter high voltage is on. Use caution when working on the transmitter high-voltage power supply, Silicon-Controlled-Rectifier (scr) charger, scr modulator, Power Supply PP-7158/TPN-18, or the 120-208 vac line connections.

Whenever the nature of the operation permits, keep one hand away from the equipment to reduce the hazard of current flowing through vital organs of the body.

Do not be misled by the term "low voltage". Potentials as low as 50 volts may cause death under adverse conditions.

B

WARNING

EXTREMELY DANGEROUS VOLTAGES EXIST IN THE FOLLOWING UNITS:

| | |
|--------------------------------|---|
| Receiver-Transmitter RT-1172/- | |
| TPN-18 | 3300 vdc, 5200 v pulsed, and 22,000 v pulsed and 120/208 vac |
| Control-Indicator C-6988A/- | |
| TPN-18 | 300 vdc, 450 vac, 10,000 vac, and 120/208 vac |

WARNING

ANTENNA SCAN CONTROL

If it is necessary to work near Antenna AS-1281/TPN-18 or Antenna AS-1292/TPN-18 with power on, make sure that scan mechanism is disabled to avoid being hit by scanning antennas. Place SCAN switch on Receiver-Transmitter RT-1172/TPN-18 control panel to OFF until after work is completed.

WARNING

RF RADIATION HAZARD

To prevent exposure to hazardous rf radiation levels, do not stand within 80 feet (24.5 m) in front of Antenna AS-1291/TPN-18 or Antenna AS-1292/TPN-18 while Radar Set ANITPN-18 is transmitting.

For Artificial Respiration, refer to FM 21-11.

WARNING

TRICHLOROTRIFLUOROETHANE

Fumes of TRICHLOROTRIFLUOROETHANE are poisonous. Provide adequate ventilation whenever you use TRICHLOROTRIFLUOROETHANE. Do not use solvent near heat or open flame. TRICHLOROTRIFLUOROETHANE will not burn, but heat changes the gas into poisonous, irritating fumes. DO NOT breathe the fumes or vapors. TRICHLOROTRIFLUOROETHANE dissolves natural skin oils. DO NOT get the solvent on your skin. Use gloves, sleeves, and an apron which the solvent cannot penetrate. If the solvent is taken internally, consult a physician immediately.

WARNING

DO NOT SERVICE OR ADJUST ALONE

Extremely dangerous voltages exist in this equipment. Do not attempt internal service or adjustment unless another person capable of rendering first aid and resuscitation is present.

**WARNING
RADIATION HAZARD**

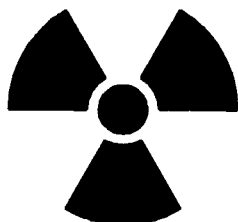

**RADIOACTIVE MATERIAL
CONTROLLED DISPOSAL REQUIRED
ACCOUNTABILITY NOT REQUIRED**

| | | | |
|------|-----------|--------|---------------------------|
| | | | STD RW--2 |
| Tube | Spark Gap | TG-163 | Cesium-137 |
| Tube | TR | 140879 | Tritium (H ₃) |

Radiation Hazard Information: The following radiation hazard information must be read and understood by all personnel operating or repairing Radar Set ANITPN-18A. Hazardous radioactive materials are present in the above listed components of the Receiver-Transmitter RT-1172/TPN-18. The components are potentially hazardous when broken. See qualified medical personnel and the local Radiological Protection Officer (RPO) immediately if you are exposed to or cut by broken components. First aid instructions are contained in TB 43-0116, TB 43-0122, and AR 755-15.

NEVER place radioactive components in your pocket. Use extreme care NOT to break radioactive components while handling them. NEVER remove radioactive components from cartons until you are ready to use them. If any of these components are broken, notify the local RPO immediately. The RPO will survey the immediate area for radiological contamination and will supervise the removal of broken components. Disposal of broken, unserviceable, or unwanted radioactive components will be accomplished in accordance with the instructions in AR 755-15.

SAFETY PRECAUTION

A periodic review of safety precautions in TB 385-4, Safety Precautions for Maintenance of Electrical/Electronics Equipment, is recommended. When the equipment is operated with covers removed, DO NOT TOUCH exposed connections or components. MAKE CERTAIN you are not grounded when making connections or adjusting components Inside the test instrument.

Technical Manual
 No. 11-5840-281-12-1

HEADQUARTERS
 DEPARTMENT OF THE ARMY
 Washington, DC, 15 January 1986

**OPERATOR'S AND ORGANIZATIONAL
 MAINTENANCE MANUAL**

**RADAR SET AN/TPN-18A
 (NSN 5840-01-070-9415)**

REPORTING ERRORS AND RECOMMENDING IMPROVEMENTS

You can help improve this manual. If you find any mistakes or if you know of a way to improve the procedures, please let us know. Mail your letter, DA Form 2028 Recommended Changes to Publications and Blank Forms), or DA Form 2028-2 located in the back of this manual direct to: Commander, US Army Communications-Electronics Command and Fort Monmouth, ATTN: AMSEL-ME-MP, Fort Monmouth, New Jersey 07703-5007. A reply will be furnished direct to you.

| | | Page |
|-----------|--|-------|
| CHAPTER 1 | INTRODUCTION | 1-1 |
| Section | I General Information..... | 1-1 |
| | II Equipment Description..... | 1-3 |
| | III Technical Principles of Operation | 1-14 |
| CHAPTER 2 | OPERATING INSTRUCTIONS..... | 2-1 |
| Section | I Description and Use of Operator's Controls and Indicators..... | 2-1 |
| | II Operator Preventive Maintenance Checks and Services (PMCS) | 2-8 |
| | III Operation Under Usual Conditions..... | 2-10 |
| | IV Operation Under Unusual Conditions..... | 2-34 |
| CHAPTER 3 | OPERATOR MAINTENANCE | 3-1 |
| Section | I Operator Troubleshooting Procedures..... | 3-1 |
| | II Operator Maintenance Procedures..... | 3-1 |
| CHAPTER 4 | ORGANIZATIONAL MAINTENANCE..... | 4-1 |
| Section | I Repair Parts, Special Tools, TMDE, and Support Equipment..... | 4-1 |
| | II Service Upon Receipt..... | 4-1 |
| | III Organizational Preventive Maintenance Checks and Services (PMCS)..... | 4-103 |
| | IV Organizational Troubleshooting | 4-105 |
| | V Organizational Maintenance | 4-117 |
| | VI Preparation for Storage and Shipment..... | 4-155 |

*This manual supersedes TM 11-5840-281-12-1, dated 12 September 1980, in its entirety.

| | Page |
|--|------------|
| APPENDIX A REFERENCES | A-1 |
| B MAINTENANCE ALLOCATION | B-1 |
| C COMPONENTS OF END ITEM AND-BSIC ISSUE ITEMS LIST | C-1 |
| D ADDITIONAL AUTHORIZATION LIST | D-1 |
| E EXPENDABLE SUPPLIES AND MATERIALS LIST | E-1 |
| GLOSSARY | Glossary-1 |
| INDEX | Index-1 |

HOW TO USE THIS MANUAL

This manual is designed to help you operate and maintain Radar Set ANITPN-18A. The front cover table of contents is provided for quick reference to important information. There is also an Index located in the final pages for use in locating specific items of information.

Measurements in this manual are given in both US standard and metric units. A metric to US standard conversion chart can be found in the back of this manual.

Warning pages are located in the front of this manual. You should learn the warnings before operating or doing maintenance on the equipment.

Paragraphs In this manual are numbered by chapter and order of appearance within a chapter. A subject index appears at the beginning of each chapter listing sections that are included in that chapter. A more specific subject index is located at the beginning of each section to help you find the exact paragraph you're looking for.

Read all preliminary information found at the beginning of each task. It has Important Information and safety instructions you must follow before beginning the task.

NOTE

All ranges are given in nautical miles (nmi) (6,080 ft).

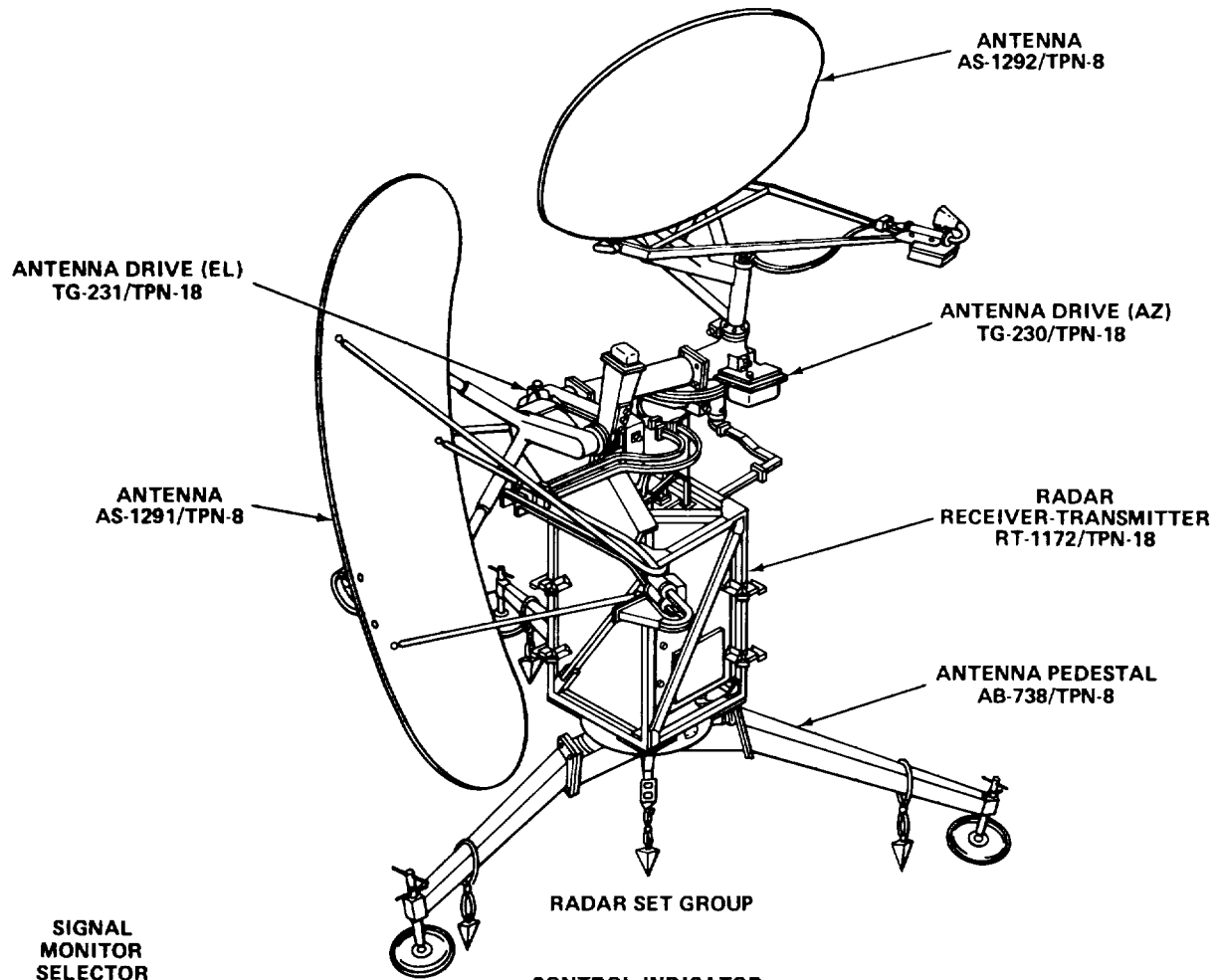

SIGNAL MONITOR SELECTOR SA-2035/TPN-18

CONTROL-INDICATOR C-6988A/TPN-18

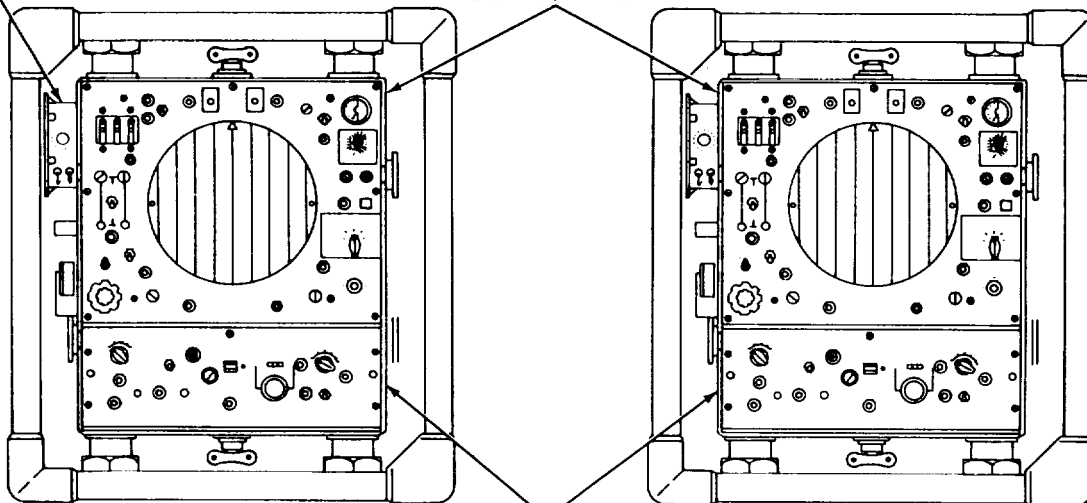

CONTROL-INDICATOR GROUP

PULSE GENERATOR O-1690/TPN-18

CONTROL-INDICATOR GROUP

305NE002

CHAPTER 1

INTRODUCTION

| Subject | Section | Page |
|---|---------|------|
| General Information | I | 1-1 |
| Equipment Description | II | 1-3 |
| Technical Principles of Operation | III | 1-14 |

Section I GENERAL INFORMATION

| Subject | Para | Page |
|---|------|------|
| Scope | 1-1 | 1-1 |
| Consolidated Index of Army Publications and Blank Forms | 1-2 | 1-1 |
| Maintenance Forms, Records, and Reports | 1-3 | 1-1 |
| Destruction of Army Materiel to Prevent Enemy Use | 1-4 | 1-2 |
| Administrative Storage | 1-5 | 1-2 |
| Reporting Equipment Improvement Recommendations (EIR) | 1-6 | 1-2 |
| Nomenclature Cross-Reference List | 1-7 | 1-2 |
| List of Abbreviations | 1-8 | 1-2 |

1-1. SCOPE.

Type of Manual: Operator's and Organizational Maintenance.

Equipment Name and Model Number: Radar Set ANITPN-18A

Purpose of Equipment: Radar Set AN/TPN-18A is a lightweight, helicopter-transportable radar set designed for use during all weather conditions. The radar set is used at forward airstrips and heliports to provide a ground controlled approach for aircraft.

1-2. CONSOLIDATED INDEX OF ARMY PUBLICATIONS AND BLANK FORMS.

Refer to the latest issue of DA PAM 310-1 to determine whether there are new editions, changes, or additional publications concerning the equipment.

1-3. MAINTENANCE FORMS, RECORDS, AND REPORTS.

REPORTS OF MAINTENANCE AND UNSATISFACTORY EQUIPMENT

Department of the Army forms and procedures used for equipment maintenance will be those prescribed by DA PAM 738-750 as contained in Maintenance Management Update.

REPORT OF PACKAGING AND HANDLING DEFICIENCIES

Fill out and forward SF 364 (Report of Discrepancy (ROD)) as prescribed in AR 735-11-2/DLAR 4140.55/NAVMATINST 4355.73A/AFR 400-54/MCO 4430.3F.

DISCREPANCY IN SHIPMENT REPORT (DISREP) (SF 361)

Fill out and forward Discrepancy in Shipment Report (DISREP) (SF 361) as prescribed In AR 55-38/NAVSUPINST 4610.33C/AFR 75-181MCO P4610.19D/DLAR 4500.15.1-1

1-4. DESTRUCTION OF ARMY MATERIEL TO PREVENT ENEMY USE.

Destruction of Army materiel to prevent enemy use shall be in accordance with TM 750-244-2.

1-5. ADMINISTRATIVE STORAGE.

Equipment to be placed in administrative storage will have preventive maintenance performed in accordance with the PMCS charts before storing. When removing the equipment from administrative storage, the PMCS should be performed to assure operational readiness. Disassembly and repacking of equipment for shipment or limited storage is covered in paragraphs 4-51 through 4-53.

1-6. REPORTING EQUIPMENT IMPROVEMENT RECOMMENDATIONS (EIR).

If your Radar Set AN/TPN-18A needs improvement, let us know. Send us an EIR. You, the user, are the only one who can tell us what you don't like about your equipment. Let us know why you don't like the design. Put it on an SF 368 (Quality Deficiency Report). Mail it to: Commander, US Army Communications-Electronics Command and Fort Monmouth, ATTN: AMSEL-ME-MP, Fort Monmouth, New Jersey 07703-5007. We'll send you a reply.

1-7. NOMENCLATURE CROSS-REFERENCE LIST.

This list contains common names used in place of official nomenclature In this manual.

| COMMON NAME | OFFICIAL NOMENCLATURE |
|---------------------------|-------------------------------------|
| azimuth antenna | Antenna AS-1292/TPN-8 |
| azimuth antenna drive | Antenna Drive TG-230/TPN-18 |
| antenna pedestal | Antenna Pedestal AB-738/TPN-8 |
| control-indicator | Control-Indicator C-6988A/TPN-18 |
| elevation antenna | Antenna AS-1291/TPN-8 |
| elevation antenna drive | Antenna Drive TG-231/TPN-18 |
| Indicator power supply | Power Supply PP-7158/TPN-18 |
| local control monitor | Control-Indicator C-9762/TPN-18 |
| pulse generator | Pulse Generator 0-1690/TPN-18 |
| receiver-transmitter | Receiver-Transmitter RT-1172/TPN-18 |
| radar set | Radar Set AN/TPN-18A |
| transmitter control panel | Control-Indicator C-9763/TPN-18 |

1-8. LIST OF ABBREVIATIONS.

This list contains uncommon abbreviations used throughout this manual.

| ABBREVIATION | WORD OR TERM |
|--------------|------------------------------|
| BITE | Built-in Test Equipment |
| clr | Centerline of Runway |
| iar | Increased Angular Resolution |
| pfn | Pulse Forming Network |
| rpl | Runway Parallel Line |
| scr | Silicon-Controlled Rectifier |
| td | Touchdown |

Section II EQUIPMENT DESCRIPTION

| Subject | Para | Page |
|---|------|------|
| Equipment Characteristics, Capabilities, and Features | 1-9 | 1-3 |
| Location and Description of Major Components..... | 1-10 | 1-3 |
| Equipment Data | 1-11 | 1-8 |
| Equipment Configuration..... | 1-12 | 1-12 |
| Safety, Care, and Handling | 1-13 | 1-14 |

1-9. EQUIPMENT CHARACTERISTICS, CAPABILITIES, AND FEATURES.

The radar set consists of three major groups of equipment: a radar set group and two control indicator groups. The radar set group contains the base pedestal, the receiver-transmitter group, azimuth antenna, azimuth antenna drive, elevation antenna, and elevation antenna drive. The two control-indicator groups are identical. Each control-indicator group consists of a control-indicator, pulse generator, and tubular frame. The radar set provides information used for air traffic control, airport surveillance radar (asr) to a maximum range of 40 nautical miles and ground controlled approach (gca) landing of aircraft. Range, azimuth, and elevation information relative to the aircraft's position is displayed to direct the aircraft along electronic cursors (elevation glidepath and azimuth course line) for a precision gca landing. A height-finding capability is provided with a direct readout of the aircraft that is within a 30-degree sector of the gca flightpath. The radar displays include an Identification Friend or Foe (IFF) presentation capability (during asr) designed for use with Interrogator Set AN/TPX-44.

1-10. LOCATION AND DESCRIPTION OF MAJOR COMPONENTS.

AZIMUTH ANTENNA

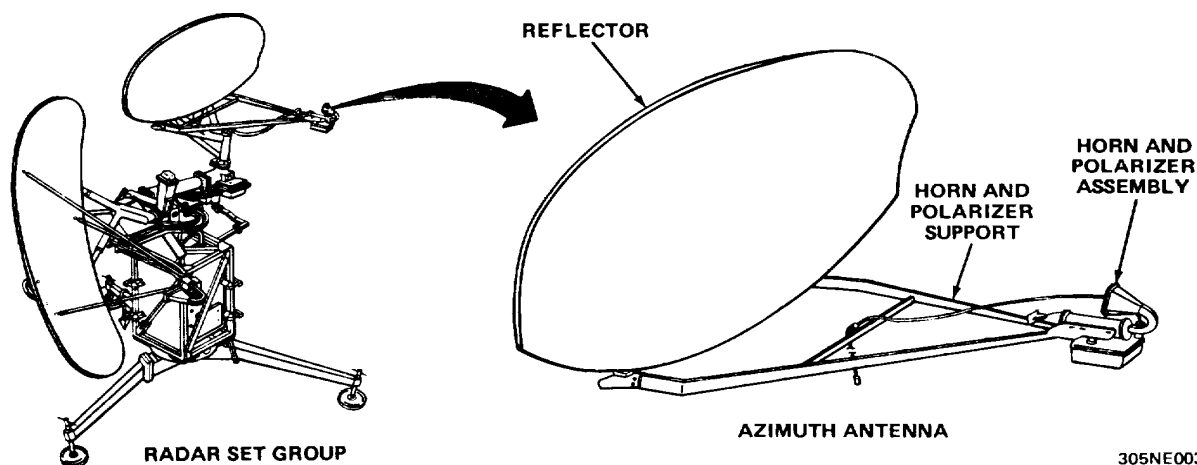

The azimuth antenna consists of an azimuth reflector, an azimuth waveguide radiation horn and polarizer assembly, and an azimuth horn and polarizer support. The reflector is constructed of a fiberglass exterior over a lightweight honeycomb. The reflecting surface is a laminate of woven metal cloth on the front side (concave side).

1.10. LOCATION AND DESCRIPTION OF MAJOR COMPONENTS. (CONT)

AZIMUTH ANTENNA DRIVE

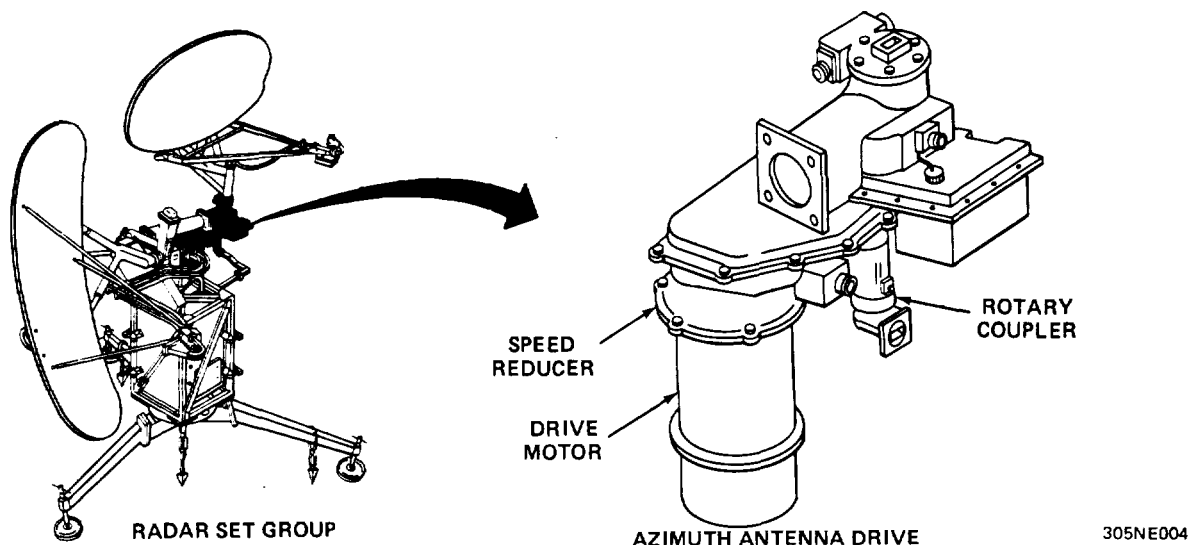

The azimuth antenna drive is attached to the elevation antenna drive support tube on top of the receiver-transmitter group and supports the azimuth antenna. The azimuth antenna drive contains the azimuth drive reducer (speed reducer), azimuth drive motor, azimuth rotary coupler, azimuth data takeoff, and azimuth slipping assembly.

ELEVATION ANTENNA

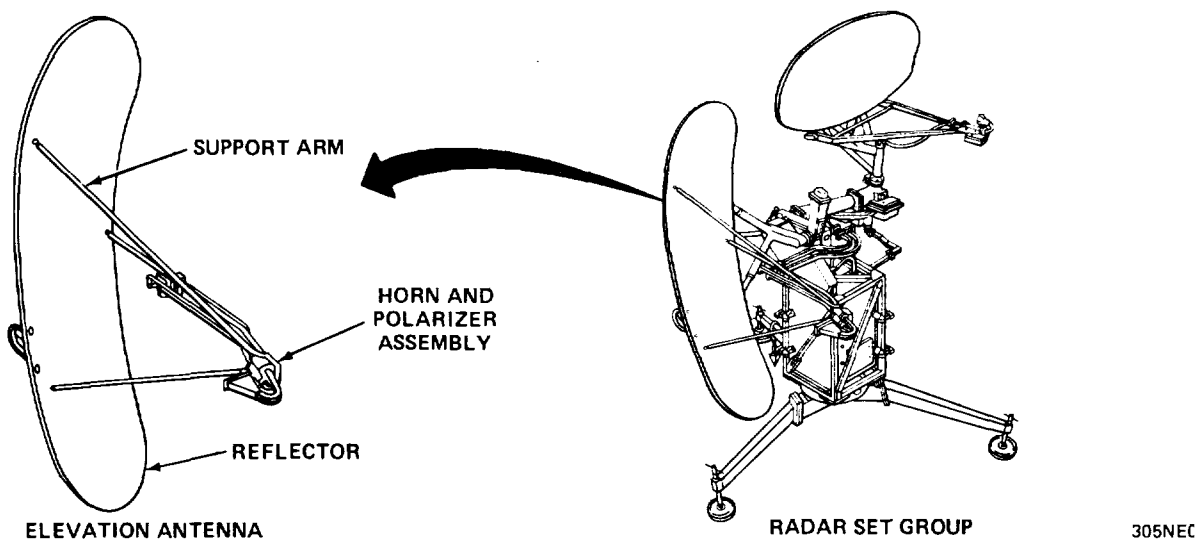

The elevation antenna consists of an elevation reflector, an elevation waveguide radiation horn and polarizer assembly, and three support arms for the waveguide radiation horn and polarizer assembly. The reflector is made of a fiberglass exterior over a lightweight honeycomb core. The reflecting surface is a laminate of woven metal cloth on the reflector side (concave side).

1-10. LOCATION AND DESCRIPTION OF MAJOR COMPONENTS. (CONT)

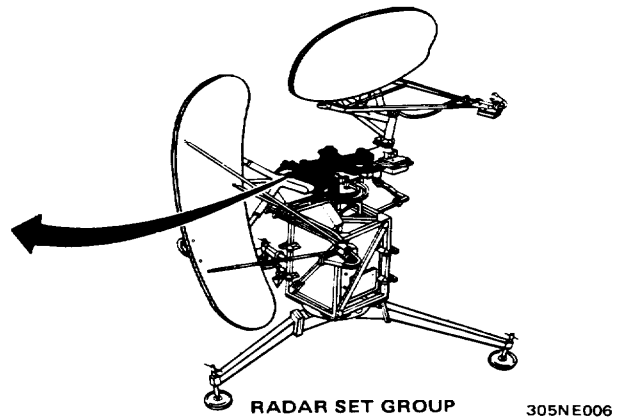
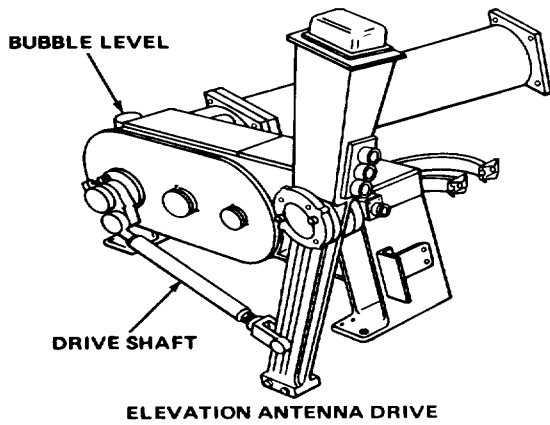

The elevation antenna drive is attached to the top of the receiver-transmitter group, and supports the elevation antenna. The drive unit contains the elevation drive motor, elevation drive gear train, elevation synchros, elevation actuator, elevation trigger and unblinking microswitches, elevation angle data potentiometer, elevation rotary coupler joints, elevation antenna drive support tube, and bubble level to level the radar set group.

BASE PEDESTAL

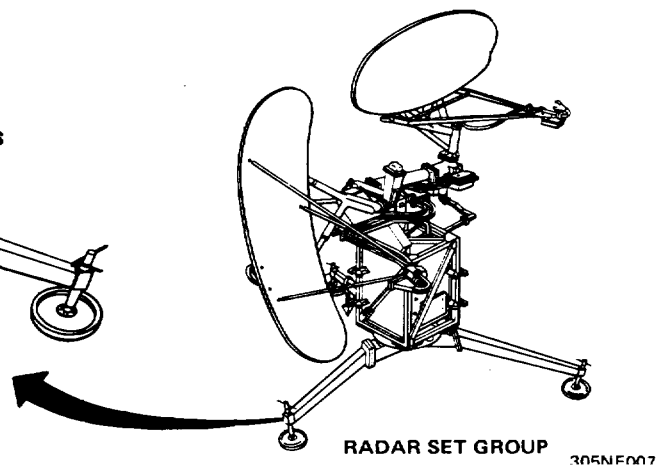
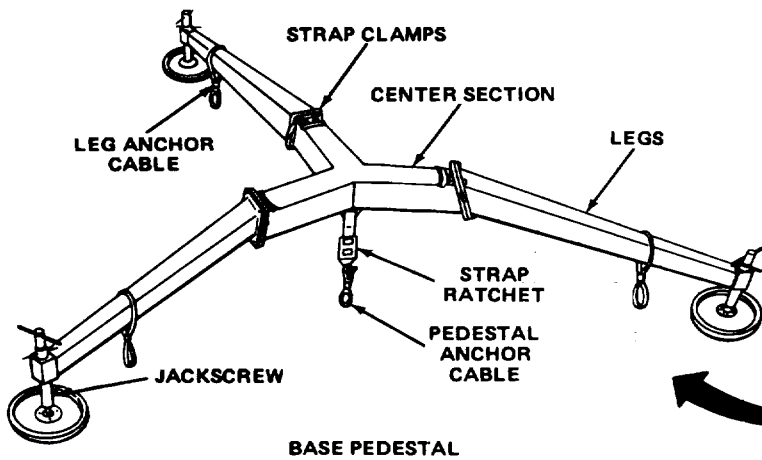

The base pedestal is the tripod assembly on which the radar set group is mounted. It consists of a center section, three legs with adjustable leveling jackscrews, and retaining hardware. The retaining hardware consists of a pedestal anchor cable, strap ratchet, three leg anchor cables, and three strap clamps. The strap clamps permit the receiver-transmitter group to be rotated and repositioned.

1.10. LOCATION AND DESCRIPTION OF MAJOR COMPONENTS. (CONT)

RECEIVER-TRANSMITTER GROUP

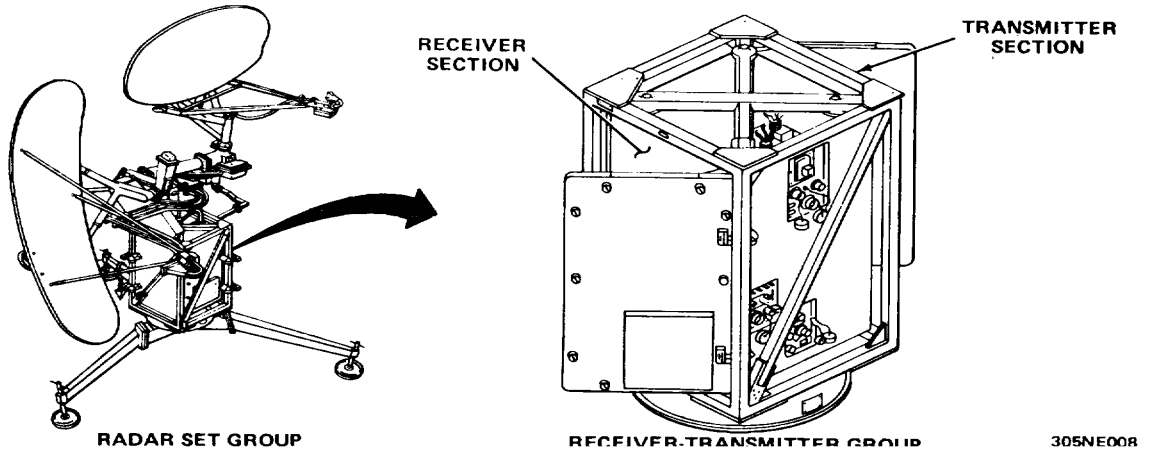

The receiver-transmitter group is contained within its own weatherproof equipment case. The receiver-transmitter equipment case is partitioned to form a receiver section and transmitter section. Hinged doors on the receiver side and the transmitter side are opened or removed to gain access to the components of the receiver and transmitter. The door for the receiver side provides storage facilities for the clinometer, card test adapter, preselector filters, and wrench set. The card extractor and sighting scope are stored on the transmitter door. When the receiver-transmitter is installed in its tubular frame, it becomes the receiver-transmitter group. The tubular frame also provides structural support for the antennas and associated drive mechanisms during operation, and serves as a shipping frame for the receiver-transmitter during transit.

CONTROL-INDICATOR GROUP

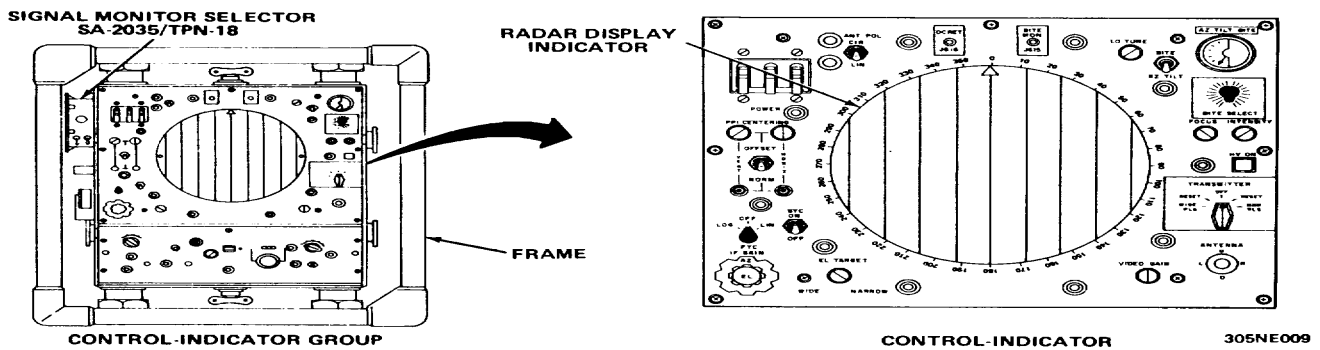

1-10. LOCATION AND DESCRIPTION OF MAJOR COMPONENTS. (CONT)

The control-indicator group is contained within its own weatherproof equipment case. It consists of the control-indicator, pulse generator, and indicator power supply. The control-indicator, along with the pulse generator, contains the operational controls for the radar set. The radar display indicator, or cathode-ray tube (crt), located in the center of the control-indicator, is used to display the processed radar video information. The radar display indicator is an integral part of the control-indicator and cannot be removed as a unit. A signal monitor selector is provided with the radar set and is mounted on the left side of one of the control-indicators. It is used at a higher level of maintenance to monitor signal waveforms on an oscilloscope.

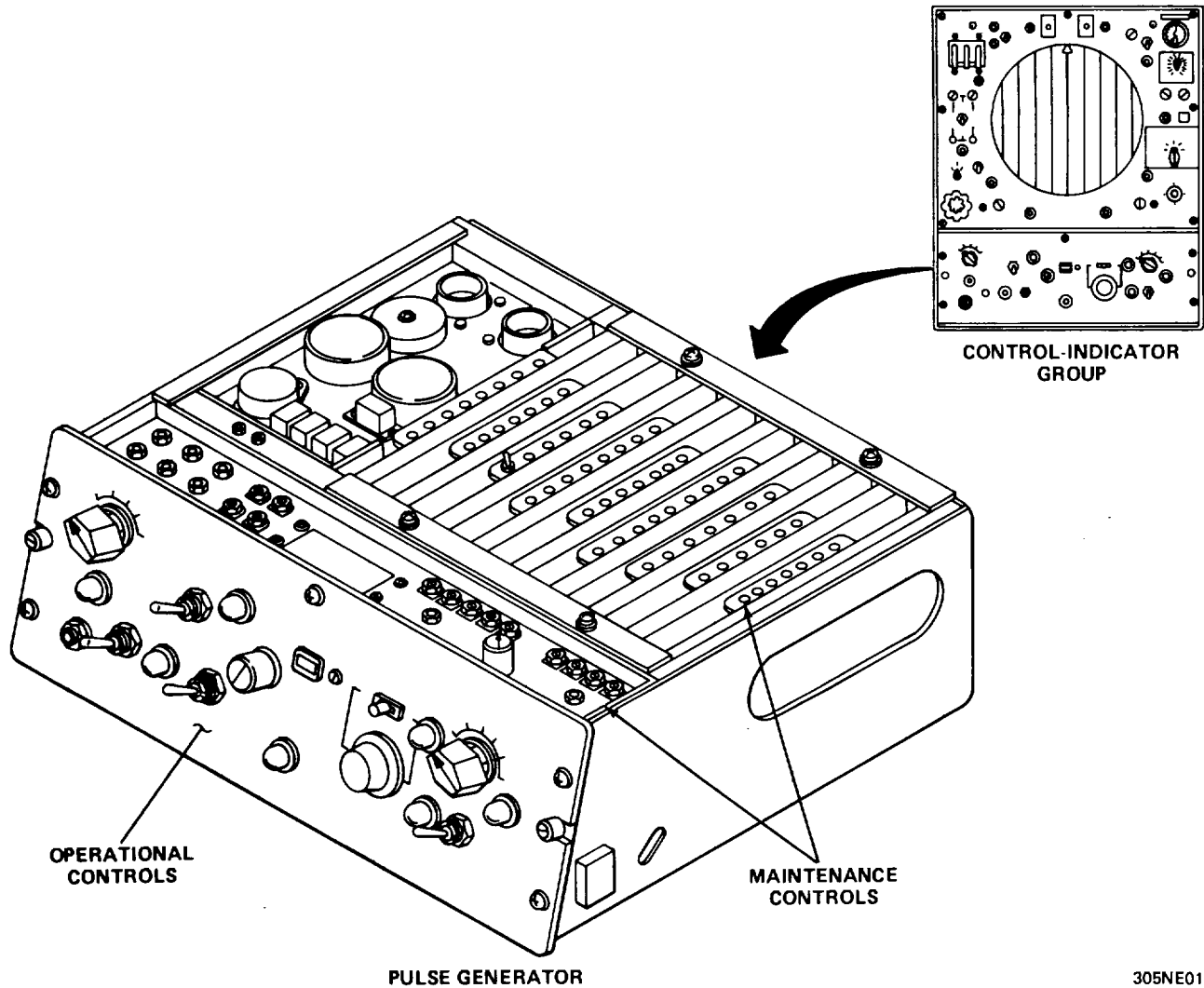

The pulse generator unit is located in the bottom-front of the control-indicator. This unit, along with the control-indicator, contains the operational controls for the radar set on the front panel and will slide out (with power applied) in order to make internal alignments and adjustments.

1-10. LOCATION AND DESCRIPTION OF MAJOR COMPONENTS. (CONT)

INDICATOR POWER SUPPLY

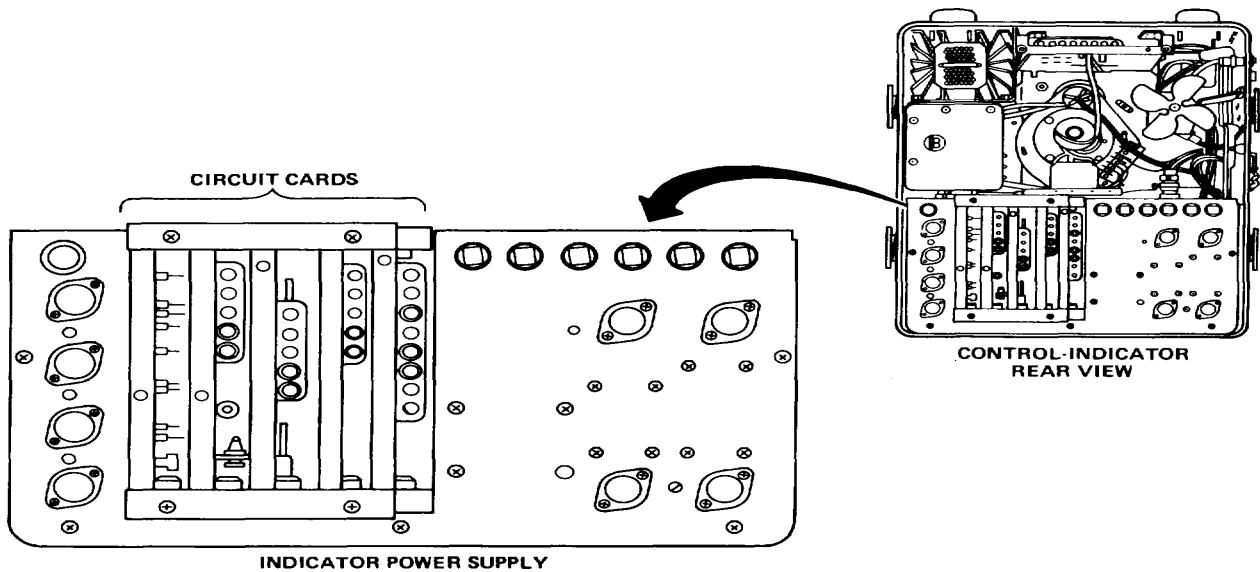

305NE011

The indicator power supply is located in the bottom-rear of the control-indicator and provides the regulated and unregulated dc voltages that are used in the control-indicator circuits.

1.11. EQUIPMENT DATA.

OVERALL SYSTEM

| | |
|---|--|
| Range (display) | |
| Minimum | 5 nmi (9 km) |
| Maximum | 40 nmi (74 km) |
| IFF (maximum) | 80 nmi (148 km) |
| Azimuth Antenna Coverage | |
| Precision | 30 degrees and 60 degrees |
| Search | 360 degrees |
| Elevation Antenna Coverage | -1 degree to + 10 degrees or - 1 degree to + 35 degrees |
| Transmitter Power | 200 kw nominal |
| Receiver Minimum Discernible Signal (MDS) | |
| Wide Pulse | - 107 db |
| Narrow Pulse | -101 db |
| Input Power | Operates from a 120/208v + 10 percent, 400 Hz ± 5 percent, 4 kw 3-phase primary power source |
| Installation time | |
| Single runway installation with partially assembled equipment | Approximately 8.5 task-hours |
| Single runway installation with packed and crated equipment | Approximately 15 task-hours |

1-11. EQUIPMENT DATA. (CONT)**ELEVATION ANTENNA**

Beamwidth (between half-power points)
Vertical

Apparent beamwidth 1.1 degree max (0.37
apparent) optimized increased angular
resolution (iar)

Horizontal

3.4 degrees max

Gain

35 db min

Polarization

Vertical or circular

Precision scan coverage

Scan -1 degree to + 10 degrees or -1 degree
to 35 degrees

Horizontal servo

± 15 degrees (0 degree to 15 degrees
left, 0 degree to 15 degrees right)

Vertical height

8 ft (240 cm)

Horizontal width

2 ft (60 cm)

AZIMUTH ANTENNA

Beamwidth (between half-power points)

Vertical

3.5 degrees max csc² to 30 degrees

Horizontal

1.2 degrees max

Gain

36.5 db

Polarization

Horizontal or circular

Scan coverage

30 degrees or 60 degrees (precision) and
360 degrees (search)

Tilt (vertical servo) from horizontal

- 1 degree to + 25 degrees

Vertical height

4 ft (120 cm)

Horizontal width

6.5 ft (193 cm)

TRANSMITTER

Operating frequency

X-band (9 to 9.6 GHz)

Pulse width

0.2 or 0.8 s

Pulse repetition frequency (prf)

1200 pps (pulse per second)

Peak power output

200 kw nominal

RECEIVER (DUAL CONVERSION)

Minimum discernible signal (mds)

Wide pulse 107 db min

Narrow pulse 101 db min

Receiver if bandwidth

Wide pulse, 2 ± 0.05 MHz

Narrow pulse, 5 + 1 MHz

Receiver ftc (lin or log)

Wide pulse, 0.8 s

Narrow pulse, 0.2 s

Receiver stc

ON or OFF operation selected by operator

Receiver tuning

Local oscillator tuning from control-
indicator and receiver front panel

Noise figure

6.6 db max

Preamp/converter

Conversion gain

30 db max

Bandwidth

12 MHz

Center frequency

290 + 2 MHz

Noise figure

2.8db

Dynamic range

36 db max

Output if frequency

60 + 0.5 MHz

Log if amplifier

Small signal gain

70 db min

Bandwidth (3 db)

7 + 1 MHz

Center frequency

60 +0.5 MHz

1-11. EQUIPMENT DATA. (CONT)**RECEIVER (DUAL CONVERSION) (CONT)**

Noise figure 10 db max
 Dynamic range 60 db (ref to input + 1 to + 6 v)

Gain control amplifier

Power gain - wide band
 - narrow pulse

Bandwidth - wide pulse 7 + 1 MHz
 - narrow pulse 2 + 0.5 MHz

Center frequency 60 MHz

Noise figure 10 db max

Gain control range 60 db min

Lin/log if amplifiers

If gain-linear 60 db min at 60 MHz

Small signal gain log 70 db min at 60 MHz

Bandwidth 7 + 1 MHz

Center frequency 60 + 0.5 MHz

Noise figure 10 db max

If delay line

Delay 0.24 s

Impedance 50 ohms

Attenuation 8db max

GaAs fet amplifier

Gain at 9 GHz to 9.6 GHz 20 +3 -0db

Instantaneous bandwidth at 1.5 db
 points 600 MHz min

Noise figure 4 db max

Frequency range Tunable 9 to 9.6 GHz

CONTROL-INDICATOR GROUPS**General**

Number of control-indicator groups (indicators) Two, one master and one slave

Indicator presentation Ppi or beta scan can be selected on both indicators in SEARCH and NORM modes, respectively; ppi display on slave indicator and beta display on master indicator in SIMULT mode only.

Remoting Separation between control-indicator and receiver-transmitter may be 250 ft (76 m) or less.

Surveillance

Type of display Ppi (10 in. (25 cm) dia crt)

Ranges Linear (5, 10, 20, and 40 nmi (9, 19, 37, and 74 km) sweeps), 80 nmi (148 km) sweep

for IFF video presentation only

Offset ranges Full radius on all ranges

Range marks 1 nmi (1.9 km) spacing on 5 and 10 nmi (9 and 19 km) sweeps, 5 nmi (9 km) spacing on 20 and 40 nmi (37 and 74 km) sweeps; 10 nmi (19 km) spacing on 80 nmi (148 km) sweep

Range mark accuracy + 2 percent

Deflection Rotating coil

1-11. EQUIPMENT DATA. (CONT)

| | |
|--------------------------------------|--|
| Scan rate | 16 + 1 rpm |
| Precision approach and height finder | |
| Display | Beta scan (azimuth and elevation) |
| Ranges | Exponential 5 and 10 nmi (9 and 19 km) sweeps; linear 20 and 40 nmi (37 and 74 km) sweeps |
| Range marks | 1 nmi (1.9 km) spacing on 5 and 10 nmi (9 and 19 km) sweeps; 5 nmi (9 km) spacing on 20 and 40 nmi (37 and 74 km) sweeps |
| Range mark accuracy | ± 1 percent |
| Azimuth display | 30- or 60-degree sector scan or 360 degrees in SIMULT mode, within - 1 to + 25 degrees elevation sector |
| Elevation display | -1 to + 10 degrees or - 1 to + 35 degrees within 30 degrees azimuth sector scan |
| Data rate (approximately) | One azimuth and one elevation presentation every second in NORM mode One azimuth and one elevation presentation every second in 350EL mode One azimuth and one elevation presentation every 2 seconds in 600AZ mode Approximately 16 azimuth and 30 elevation presentations every 60 seconds in SIMULT mode |
| Glidepath cursors (elevation) | Two preset electronic cursors for each control-indicator, adjustable to any glide slopes from + 1 to + 45 degrees in elevation. |
| Runway cursors (azimuth) | Two preset electronic cursors for each control-indicator, adjustable to any runway heading reciprocal within siting criteria. |
| Height finding | 300 to 30,000 ft (92 to 9200 m) with accuracy of 0.4 percent of range and + 10 percent in altitude |
| SERVICE CONDITIONS | |
| Ambient temperature | |
| Operating | - 400C (- 400F) to + 71 °C (+ 1600F) |
| Nonoperating | - 500C (- 580F) to + 71 °C (+ 1600F) |
| Relative humidity | No adverse effects up to 95 percent relative humidity (operating and nonoperating) |
| Altitude | |
| Operating | Sea level to 10,000 ft (3100 m) |
| Nonoperating | Sea level to 50,000 ft (15,500 m) |
| Winds | |
| Operating | 43 knots with holddown stake |
| Nonoperating | 100 knots with holddown stake |
| Vibration and shock | No damage or impairment to operation when subjected to sinusoidal vibration or shock encountered during transport |
| Transport | Cargo transport helicopter capable of transporting 3643 lb (shipping gross weight) or 2 1/2-ton M-35 truck |
| Gross weight | 3643 lb |

1-11. EQUIPMENT DATA. (CONT)

WEIGHTS AND DIMENSIONS

| COMPONENT | DIMENSIONS in. (cm) | | DEPTH | WEIGHT lb (kg) |
|---|------------------------|-------------|-------------|-------------------|
| | HEIGHT | WIDTH | | |
| Antenna Pedestal | 26 (66) | 56 (142) | 56 (142) | 102 (46) |
| Azimuth Antenna Drive | 15 1/2 (39) | 17 1/2 (45) | 14 (36) | 225 (102) |
| Elevation Antenna Drive | 30 1/2 (78) | 35 (89) | 23 1/2 (60) | 205 (93) |
| Elevation Antenna | 96 (244) | 24 (61) | 67 (170) | 227 (103) |
| Azimuth Antenna | 54 (137) | 78 (198) | 48 (122) | 155 (70) |
| Control-Indicator (two) (With Frame) | 26 (66) | 24 (61) | 24 (61) | 187 (85) |
| Receiver-Transmitter (With Frame and Base) | 42 (107) | 34 (86) | 36 (92) | 580 (263) |

Cable assembly W3007 is 8 feet (2.5 m) long. Cable assembly W3006 is 10 feet (3 m) long. Cable assemblies W9501, W9502, W9503, and W9504 are 25 feet (7.5 m) long. Cable assemblies W3003 and W3004 are 135 feet (41 m) long. Cable assemblies W3001, W3002, and W3005 are 250 feet (76 m) long. The total weight of all the cable assemblies is 1060 pounds (481 kg).

1-12. EQUIPMENT CONFIGURATION.

The ANITPN-18A radar set can be installed in two basic configurations: unshelterized and shelterized.

UNSHELTERIZED CONFIGURATION

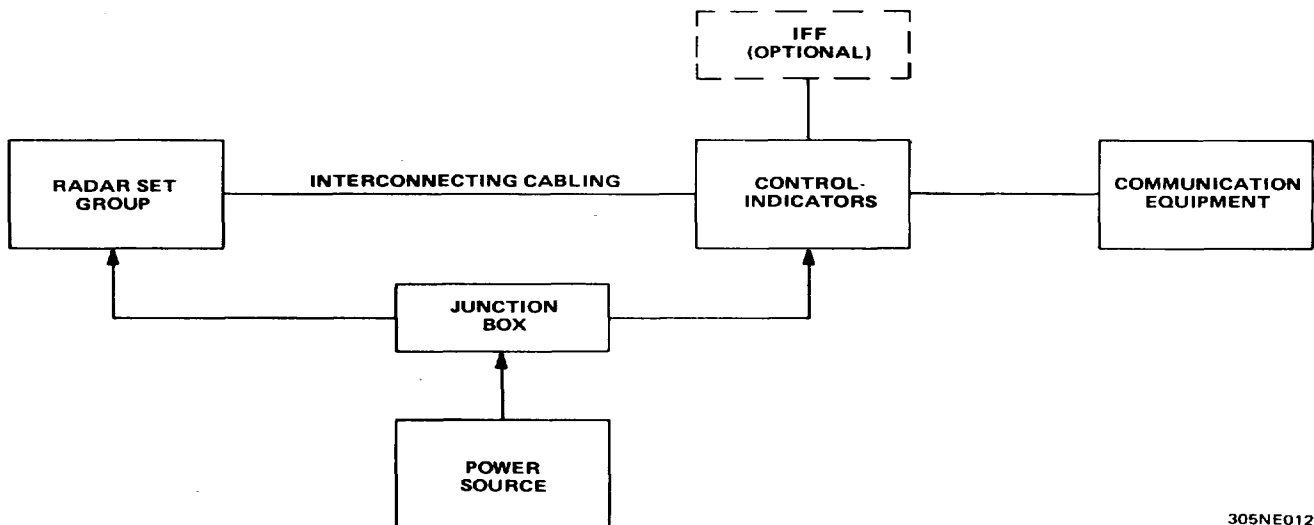

305NE012

1-12. EQUIPMENT CONFIGURATION. (CONT)

In the unsheltered configuration, the IFF input from the ANITPX-44 interrogator set is optional. When utilizing the IFF input, refer to TM 11-5895-468-12 for operation of the ANITPX-44 interrogator set. There are no IFF operator controls on the AN/TPN-18A radar set. Also, only one control-indicator may be used to operate the radar set in this configuration.

SHELTERIZED CONFIGURATION

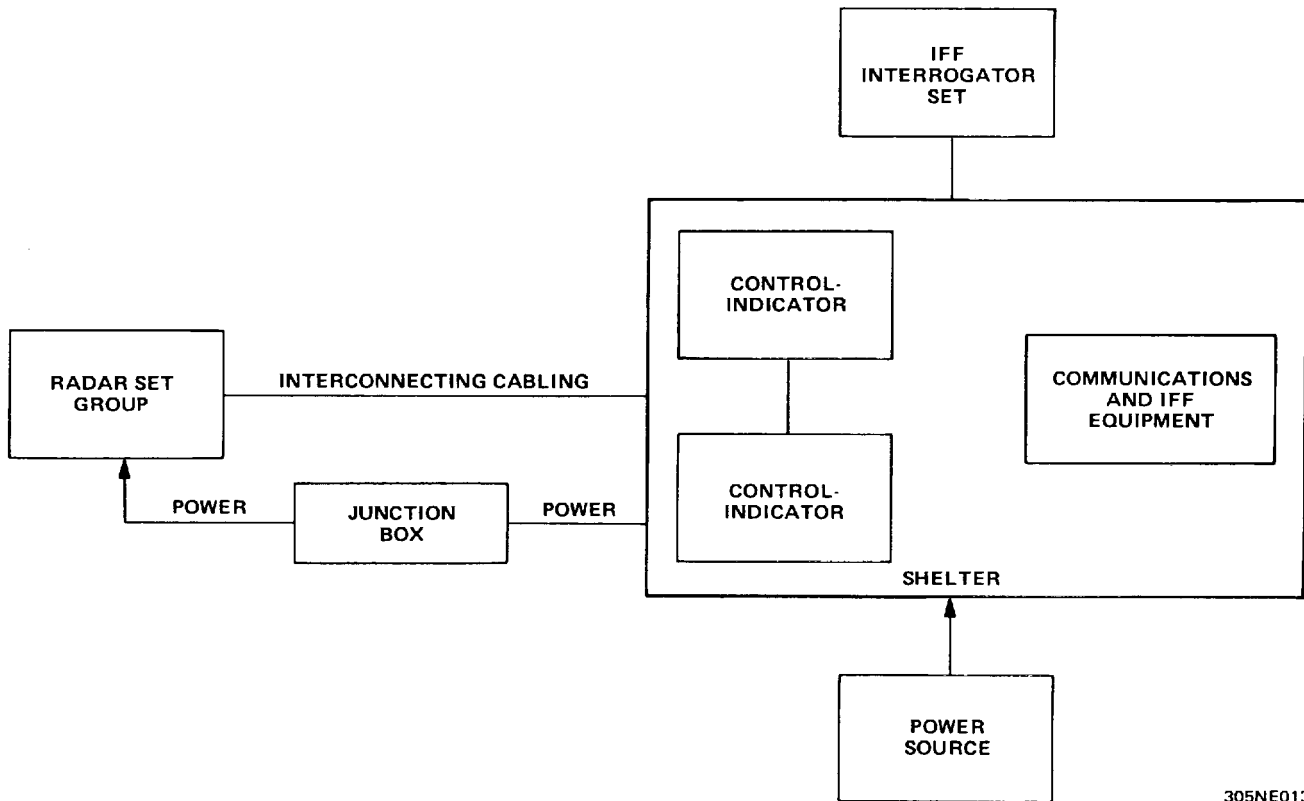

305NE013

In the shelterized configuration the radar set is installed as part of a landing control central system (AN/TSQ-71 B). The system provides shelterization, primary ac power, and interconnecting cabling and control to Interrogator Set ANITPX-44. Also, interconnecting cabling is provided for the control-indicators. Radio, telephone, visual communications, and environmental control facilities are also incorporated in the system for air-to-ground communications and for tie-in to tower and air traffic control facilities. The radar set group is installed on a trailer. The pedestal center section is anchored to the trailer and the legs are stored on the trailer. Refer to TM 11-5895-474-12 addendum for a complete description and operation of Landing Control Central ANITSQ-71 B.

1-13. SAFETY, CARE, AND HANDLING.

GENERAL

Overexposure to microwave radiation from the ANITPN-18A radar set can result in health hazards (see TB MED 270). Hazardous radiation power density levels (above 10 milliwatts per square centimeter (mw/cm²)) exist at distances within 80 feet (24.5 m) of the azimuth reflector and 33 feet (10 m) of the elevation reflector when the radar is in the nonscan mode. In the scan mode, the main beam output power density level is less than 10 mw/cm² and is not hazardous. However, hazardous radiation levels do exist at the azimuth and elevation antenna feed horns and within 6 inches (15 cm) behind and to the left of the elevation antenna reflector.

Do not install the radar set group within 80 feet (24.5 m) of any elevated structure and post rf radiation hazard warning signs of the formation in AR 385-30 at four points around the radar set group after installation and before operating.

Do not stand in front of either antenna when it is radiating or within a distance of 12 inches (30 cm) of elevation antenna when radiating and alert personnel to the potential radiation hazard existing directly behind the elevation antenna.

Radiate only when necessary and do not direct the radiating antenna toward occupied areas within the antenna's potential hazard range of 80 feet (24.5 m).

Do not use worn or damaged flexible waveguides as they can leak hazardous levels of microwave radiation and avoid exposure to the open end of a waveguide when it is connected to an operating microwave generator.

Conduct periodic safety briefings, as appropriate, including hazard and control procedures for microwave radiation.

Care should be taken when making settings or adjustment of certain controls. Careless operation or improper settings can damage the radar set and injure operating personnel.

The INTENSITY control on both control-indicators should always be full counterclockwise when the radar set is turned on or shut down to prevent burning holes in the crt coating.

The monitor switch, on the local control monitor panel, should be set to METER CAL position when the radar set is operating to prevent damage to the meter.

The BITE-AZ TILT switch, on both control-indicators, should be set to AZ TILT position to prevent incorrect readings on the AZ TILT/BITE meter during normal operations.

Section III TECHNICAL PRINCIPLES OF OPERATION

| Subject | Para | Page |
|--|------|------|
| System Principles of Operation | 1-14 | 1-15 |
| Component Principles of Operation..... | 1-15 | 1-17 |

1-14. SYSTEM PRINCIPLES OF OPERATION.

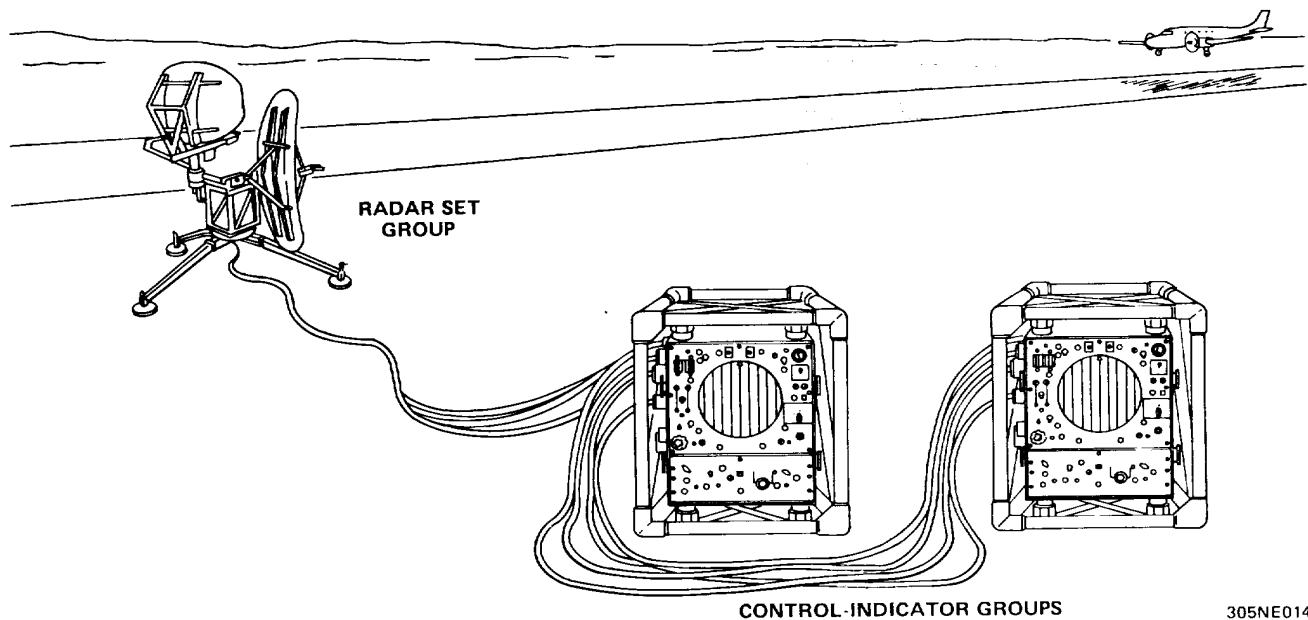

305NE014

The radar set group consisting of the receiver-transmitter, antennas, antenna drives, and pedestal is located adjacent to the runway. The two control-indicator groups together can be located up to 250 feet from the radar set group. The control-indicator that is cable-connected (three cables) to the radar set group is designated the "master" and controls the operation of the radar set group. The other control-indicator is connected by four cables to the master and is designated the "slave". The control-indicators are identical and in an emergency may be interchanged as described in Emergency Procedures (para 2-15). When in the shelterized configuration, both control-indicators are installed inside the shelter and either control-indicator can be selected the master by using the MASTER IND 1-2 switch. Refer to TM 11-5895-474-12 addendum for information relating to the AN/TSQ-71 B landing control system.

The receiver-transmitter group may be manually rotated on the antenna pedestal to any reciprocal of a runway heading through 360 degrees. This enables gca landing service to two runways from one site location with a minimum of system realignment. More than two runways may be serviced from one site location, provided the radar set group is reoriented and the cursors are realigned.

1.14. SYSTEM PRINCIPLES OF OPERATION. (CONT)

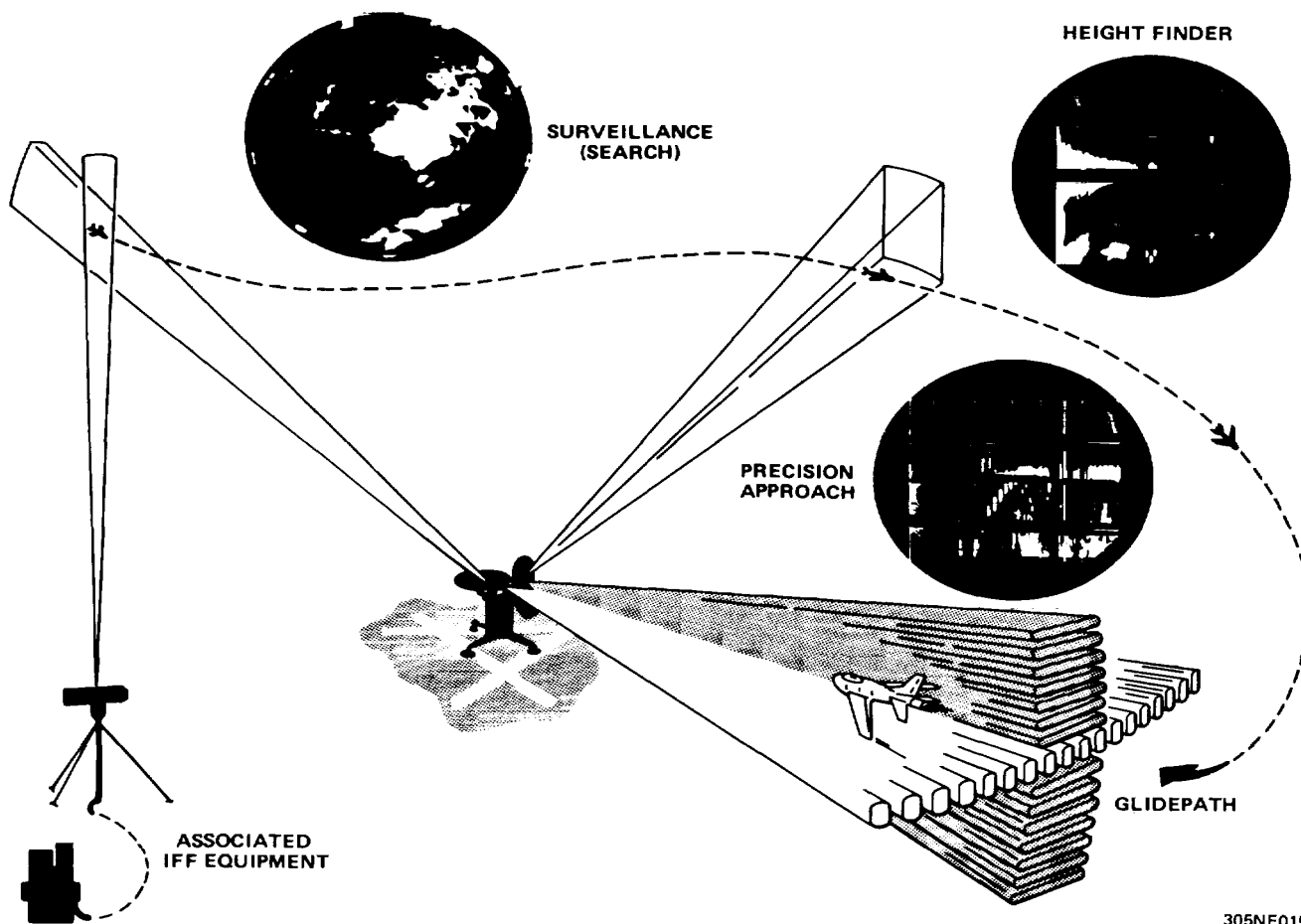

When the surveillance function (search mode) is used, the operator can detect small aircraft within a radius of 25 miles and large aircraft within a 40-mile radius. When associated IFF equipment is used, IFF transponder-equipped aircraft may be detected up to 80 miles. Targets are detected and their range and azimuth are displayed on a ppi display. The operator can then guide the aircraft, using radio communication, into the correct position for making an approach to the airfield.

During the surveillance function, when challenging with auxiliary IFF equipment, the target and coded "blip" is present on the 5-, 10-, 20-, and 40-mile range displays. On the 80-mile range display, only the IFF target is present. The IFF information provides the operator with a quick means of target identification.

1-14. SYSTEM PRINCIPLES OF OPERATION. (CONT)

When the height finder function is used, the operator can determine the altitude of an aircraft (off the approach end of the active runway) that is within the scan and servo limits of the elevation antenna (0 to 35 degrees in elevation and 30 degrees in azimuth).

When the precision approach or final approach function is used, the operator can guide the aircraft along the proper glidepath and course line to within 20 feet of the touchdown point. Azimuth and elevation information is continuously displayed on the crt display using a beta scan presentation. The display also provides the operator with range information, so that the exact position of the aircraft can be determined at any instant during the final approach.

1.15. COMPONENT PRINCIPLES OF OPERATION.

RECEIVER-TRANSMITTER

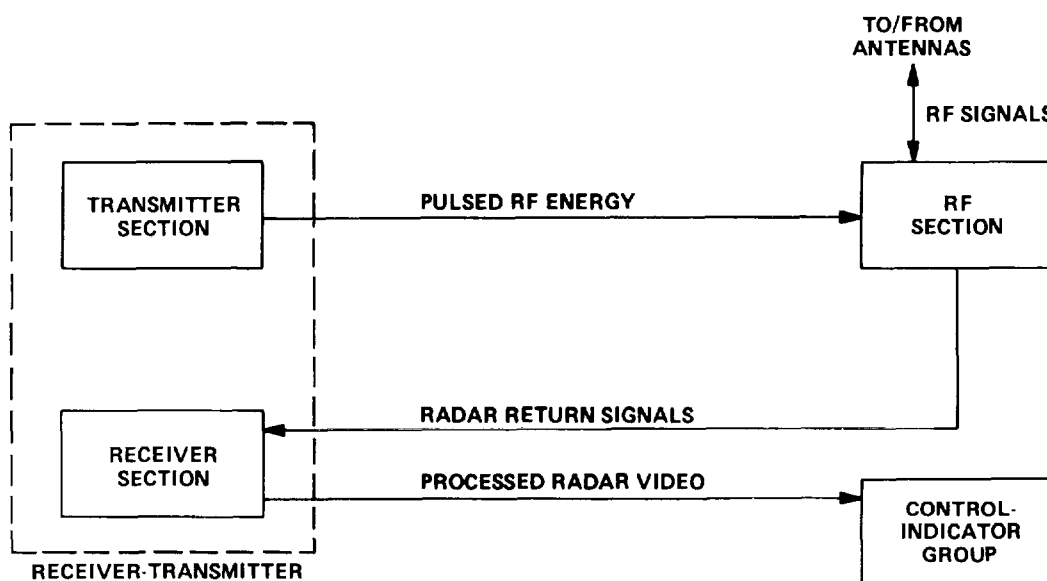

305NE124

The receiver-transmitter generates and receives the rf signals used in the operation of the radar set. The transmitter section generates pulsed rf energy that is routed to the rf section. The rf section emits this pulsed rf energy from the azimuth and elevation antennas. The return signal from a target is then picked up by the antennas and routed through the rf section to the receiver section. The receiver section then processes and amplifies the signal into a radar video. The radar video is then routed from the receiver section to the control-indicator, where it is displayed on the crt. The time between pulses of the transmitter allows the rf energy transmitted during one pulse to reach the target and return before the next pulse is transmitted.

1-15. COMPONENT PRINCIPLES OF OPERATION. (CONT)

AZIMUTH AND ELEVATION ANTENNAS

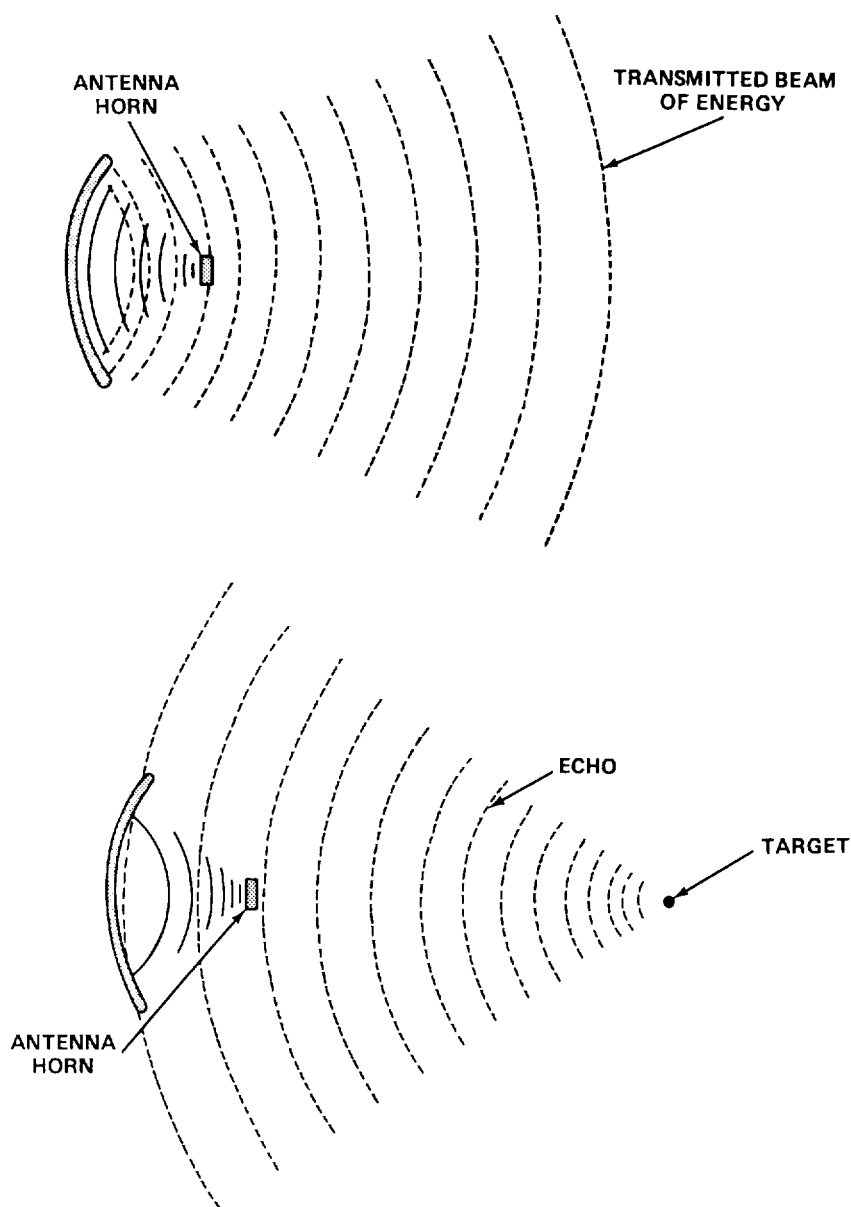

305NE130

The azimuth and elevation antenna reflectors are used to shape and direct the pulsed rf energy from the receiver-transmitter. The pulsed rf energy from the transmitter leaves the antenna horn and strikes the antenna reflector. The antenna reflector reflects the rf energy out in the form of a narrow beam. When this beam strikes a target, a portion of the beam is reflected back toward the antenna. The reflected beam, which is called an echo, then strikes the antenna reflector and is used to produce an image on the crt that represents the target.

1-15. COMPONENT PRINCIPLES OF OPERATION. (CONT)

AZIMUTH AND ELEVATION ANTENNA DRIVES

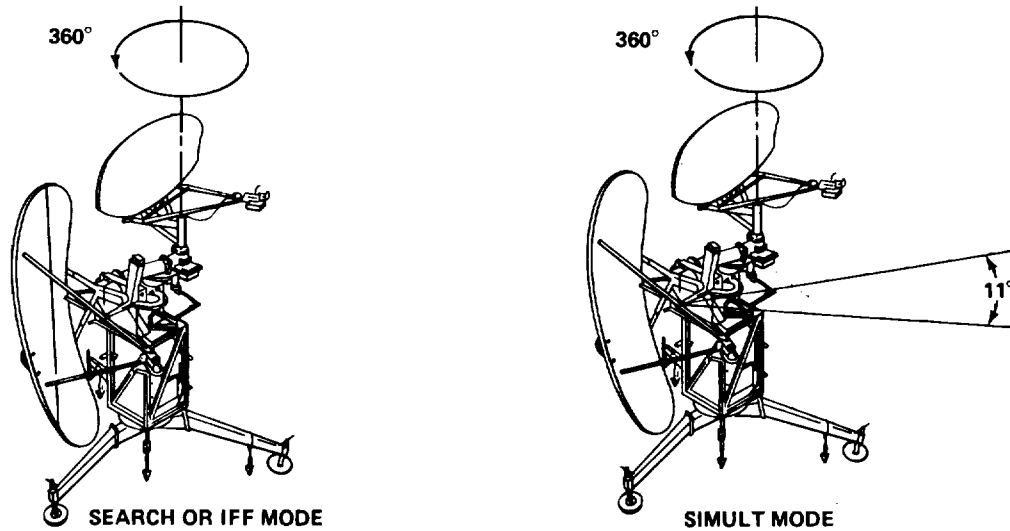

305NE125

The azimuth and elevation antenna drives provide the mechanical drive power to rotate the azimuth and elevation antennas through their respective scans. When the radar set is operated in the SEARCH, SIMULT, or IFF modes, the azimuth antenna drive rotates the azimuth antenna through 360 degrees in azimuth at approximately 16 revolutions per minute. The elevation antenna is not used during SEARCH or IFF modes, but in SIMULT mode the elevation antenna drive will provide the drive power to drive the elevation antenna up and down through 11 degrees in elevation.

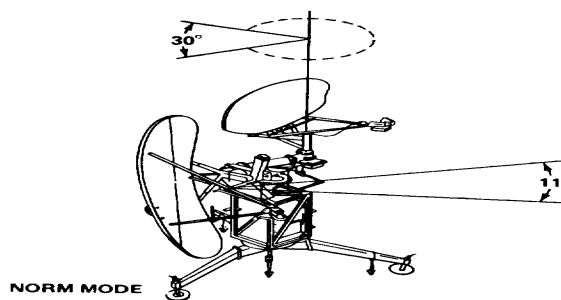

305NE126

When the radar set is operated in the NORM (precision approach) mode of operation, both the azimuth and elevation antennas are scanning. The azimuth antenna drive will move the azimuth antenna back and forth through a 30-degree sector scan in azimuth. At the same time, the elevation antenna drive will provide the drive power to move the elevation antenna up and down through 11degrees in elevation.

1-15. COMPONENT PRINCIPLES OF OPERATION. (CONT)

AZIMUTH AND ELEVATION ANTENNA DRIVES (CONT)

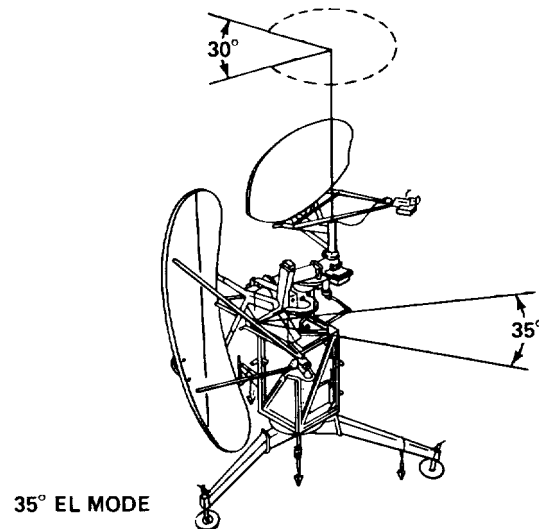

If the 35°EL mode of operation is chosen, the azimuth antenna will scan back and forth through a 30-degree azimuth sector. The elevation antenna drive will drive the elevation antenna up and down through a 35-degree vertical scan.

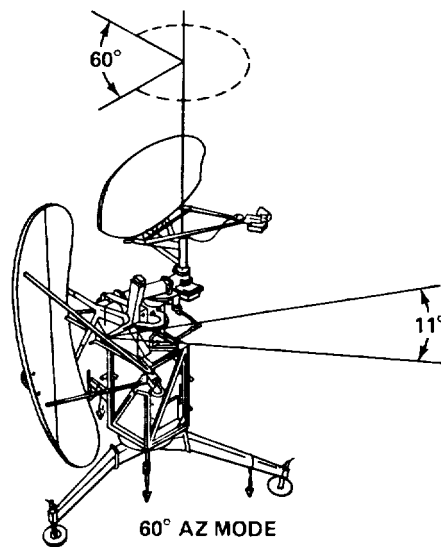

305NE12B

When the 600AZ mode of operation is selected, the azimuth antenna drive will drive the azimuth antenna back and forth through a 60-degree azimuth sector. The elevation antenna drive will move the elevation antenna up and down through 11 degrees in elevation.

1-15. COMPONENT PRINCIPLES OF OPERATION. (CONT)

CONTROL-INDICATOR

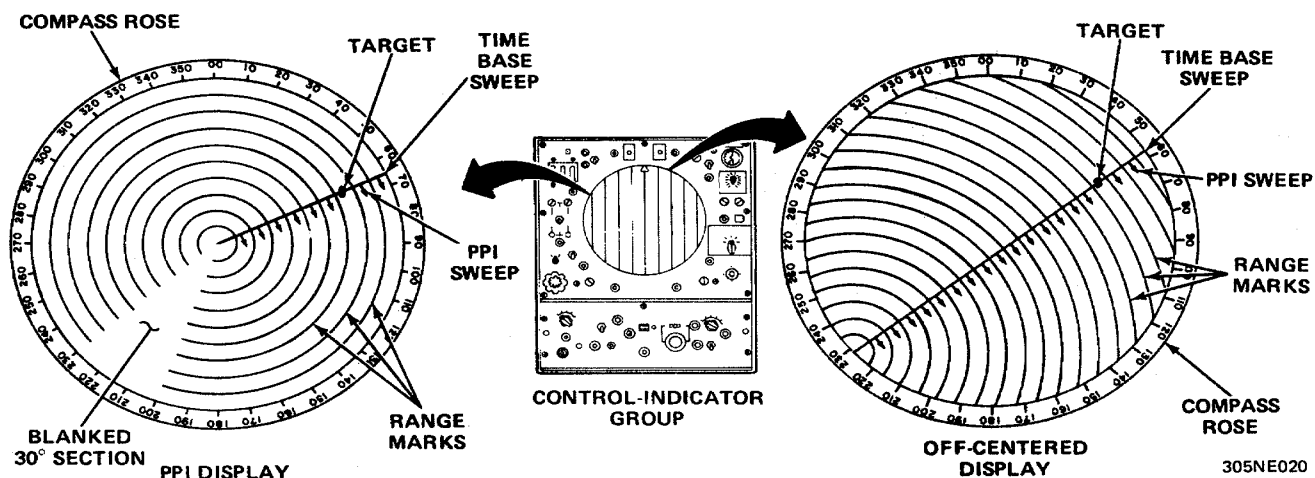

The most important function of the control-indicator is to display the radar information on a crt. When the information is displayed, the operator must be able to interpret what he or she sees and use the information to guide an aircraft to the runway for a safe landing. The use of the controls is described in paragraph 2-1.

PPI DISPLAY

The plan position indicator (ppi) display is used for search operation when operating in SEARCH, SIMULT, or IFF modes. The time-base sweep is produced by a point of light that starts at the center of the crt and moves to the outer edge. The starting time is synchronized with the transmitted pulse that leaves the antenna. The sweep rotates around the crt in synchronization with the azimuth antenna, approximately 16 revolutions per minute. The antenna receives an echo only when it is pointing directly at the target, and the echo produces a bright spot on the time-base sweep that represents the target. The azimuth of the target can be read on the compass rose as the time-base sweep goes past it. Because the time-base sweep indicates the direction of the beam, and the target position along the sweep indicates the position in time (hence the range), a maplike picture of the airspace around the radar set is created. Such a display is commonly referred to as a ppi display.

The ppi display utilizes ranges of 5, 10, 20, 40, and 80 nautical miles. When an 80-mile range is selected, a target is not displayed, only the IFF return will be seen when operating in conjunction with auxiliary IFF equipment. For 5 and 10-mile ranges, the range marks will represent 1-mile intervals, and 5-mile intervals for 20- and 40-mile ranges. A 30-degree sector of the range marks is blanked to represent the precision approach path (the direction of the approach to the active runway). This allows the operator to guide the aircraft to the approach end of the runway.

OFF-CENTERED DISPLAY

Normally the center of the ppi display represents the location of the radar set. If necessary, the operator can shift this central point to one edge of the crt to extend the range in a particular direction by utilizing the PPI CENTERING controls.

1-15. COMPONENT PRINCIPLES OF OPERATION. (CONT)

DUAL BETA DISPLAY

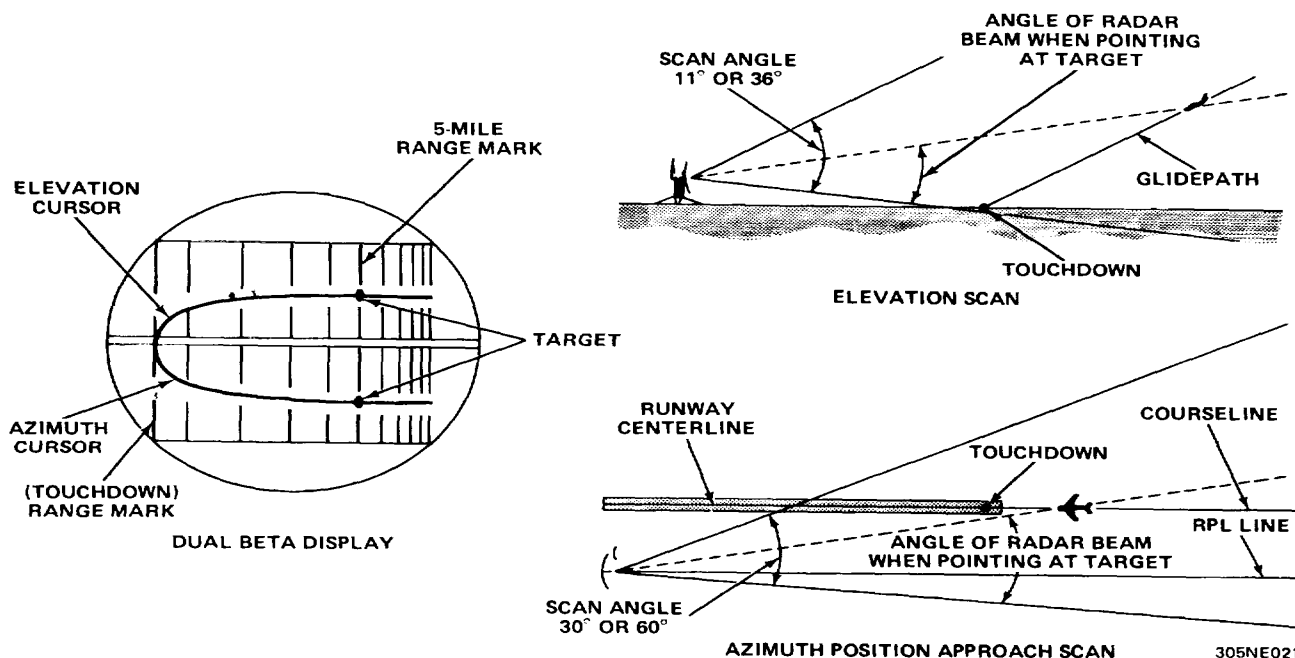

The dual beta display is used for precision approach operation when operating in NORM, 35°EL, 60°AZ, or SIMULT modes. When the aircraft is within 6 to 8 miles from touchdown, the operator switches to a precision mode in order to guide the aircraft in for a landing. The mode selected depends on the azimuth and elevation of the aircraft as it approaches the runway. The 35°EL mode is used to provide wide vertical coverage for steep glidepaths and the 60°AZ mode provides wide horizontal coverage when required. The NORM mode provides 30 degrees in azimuth and 11 degrees in elevation coverage and the SIMULT mode provides 360° degrees in azimuth and 11 degrees in elevation coverage. The SIMULT mode utilizes two control-indicators: master and slave. The master has a dual beta display for precision approaches and the slave a ppi display for search operation.

The dual beta display is a double display (elevation and azimuth) on the crt at the same time. The upper display is elevation and the lower is azimuth and represents the area scanned by each antenna (elevation and azimuth). The time-base sweep extends horizontally across the crt and moves up and down in step with the scanning action of each antenna. There is a curved line (cursor) on both the elevation and azimuth displays. The cursors have been preset during alinement to represent the glidepath (best angle of descent) on the elevation display and the courseline (bearing of the runway) on the azimuth display. When the radar set is installed on the left side (facing landing aircraft) of the runway, the azimuth cursor will curve up. When installed on the right side, it will curve down.

1-15. COMPONENT PRINCIPLES OF OPERATION. (CONT)

The position of the target on each display depends on the position of the time-base sweep at the instant an echo is received. The position of the sweep will coincide with the scan angle of each antenna. By using the cursors as a reference, the operator can tell whether or not the aircraft is on the proper glidepath and course line. As in the ppi display, the sweep ranges are the same with the exception that the range marks are vertical with range increasing to the right. When the 5- or 10-mile range display is selected, the time-base sweep is modified to expand the spacing of the range marks nearer touchdown and thereby increase resolution of targets nearing touchdown.

HEIGHT FINDER DISPLAY

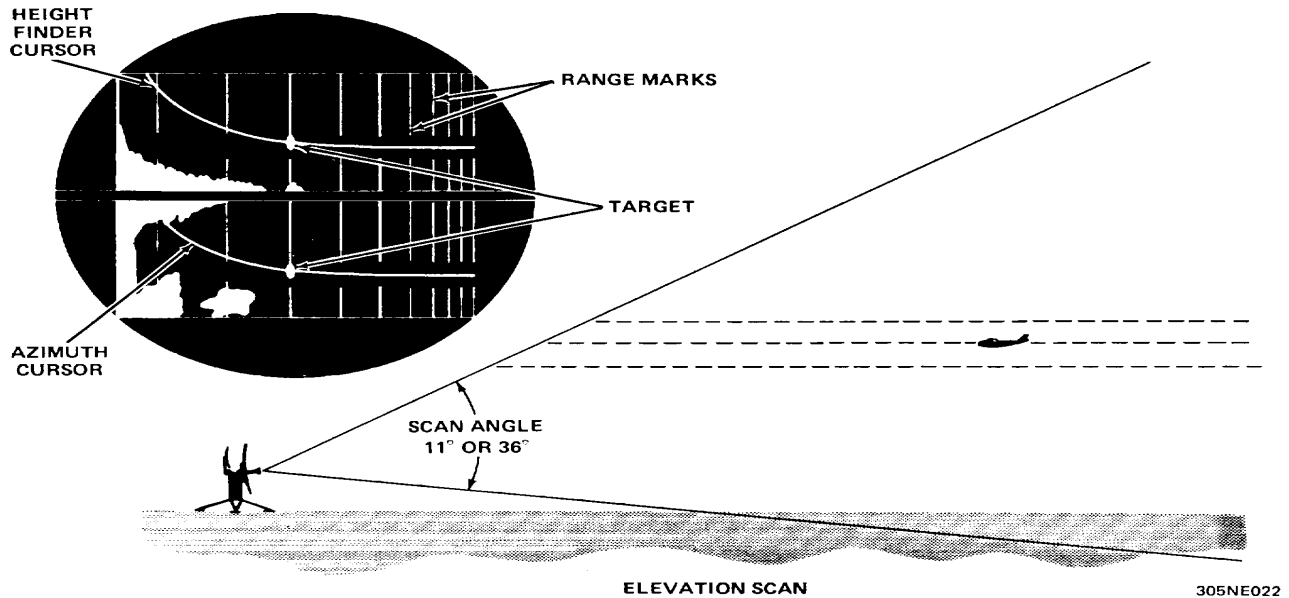

The height finder display is used during the precision approach operation to determine the altitude of an aircraft approaching the runway. As in the dual beta display, the operator must select the mode of operation (NORM, 350EL, 600AZ or SIMULT) that best suits his or her needs.

The azimuth antenna is not used for height finder information. It continues to scan as in the precision approach operation and the azimuth display remains on the lower half of the crt. During height finder operation, a different cursor (called the height finder cursor) appears on the elevation display. The height finder cursor has been prealigned, but it is not fixed. It can be shifted to represent any line of constant altitude above the ground or mean sea level. Targets appear on the elevation display the same as on the dual beta display. The operator shifts the height finder cursor so that it intersects the target. At this point, the cursor represents a horizontal line drawn at the altitude of the target. The height of the target is indicated in hundreds of feet on the ALTITUDE indicator. All range marks are the same as on the dual beta display.

1-15. COMPONENT PRINCIPLES OF OPERATION. (CONT)

PULSE GENERATOR

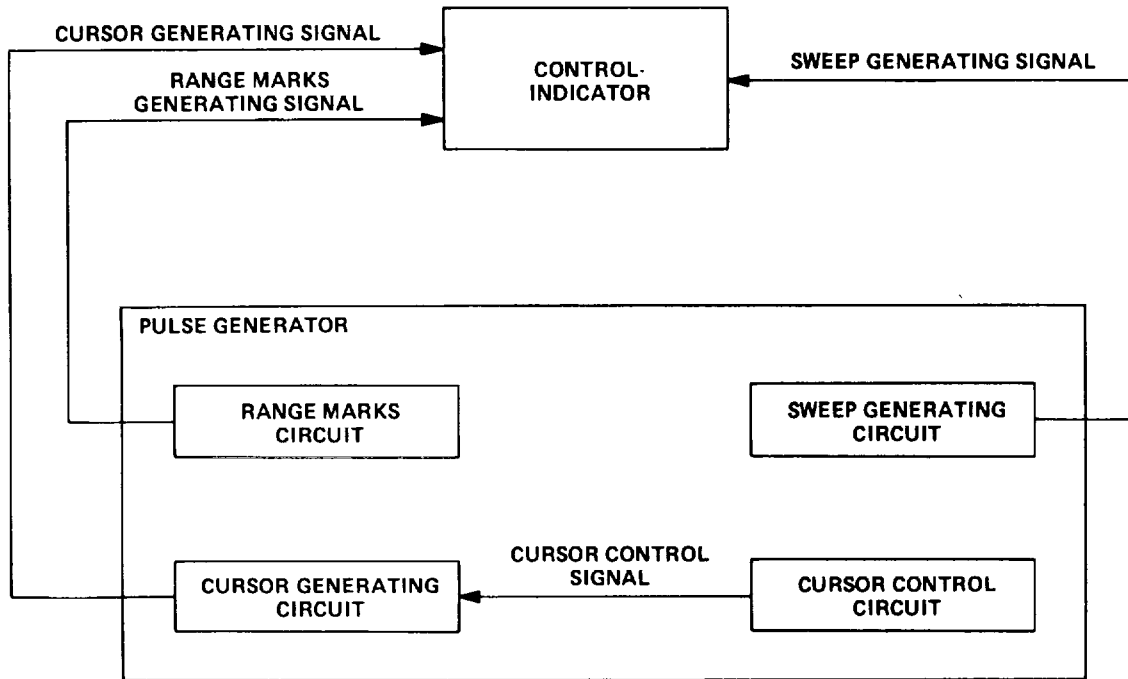

305NE129

The pulse generator can be subdivided into four functional subsections consisting of nine plug-in circuit cards. The four subsections can be identified as the range mark circuits, sweep generating circuits, cursor generating circuits, and cursor control circuits. The range mark subsection generates accurately spaced 1-mile range marks for the 5- and 10-mile display ranges, 5-mile range marks for the 20- and 40-mile display ranges and 10-mile range marks for 80-mile display range (IFF operation). The sweep generating subsection provides a logarithmic 5 and 10-mile and linear 20- and 40-mile time base for precision mode ranges and a linear time base for all search mode ranges. The cursor generating subsection produces the courseline cursors for the azimuth display, and the glidepath and elevation cursors for the elevation display. The cursor control subsection uses antenna angle data and reference voltages to properly time and switch the cursor generating circuits.

1-15. COMPONENT PRINCIPLES OF OPERATION. (CONT)

INDICATOR POWER SUPPLY

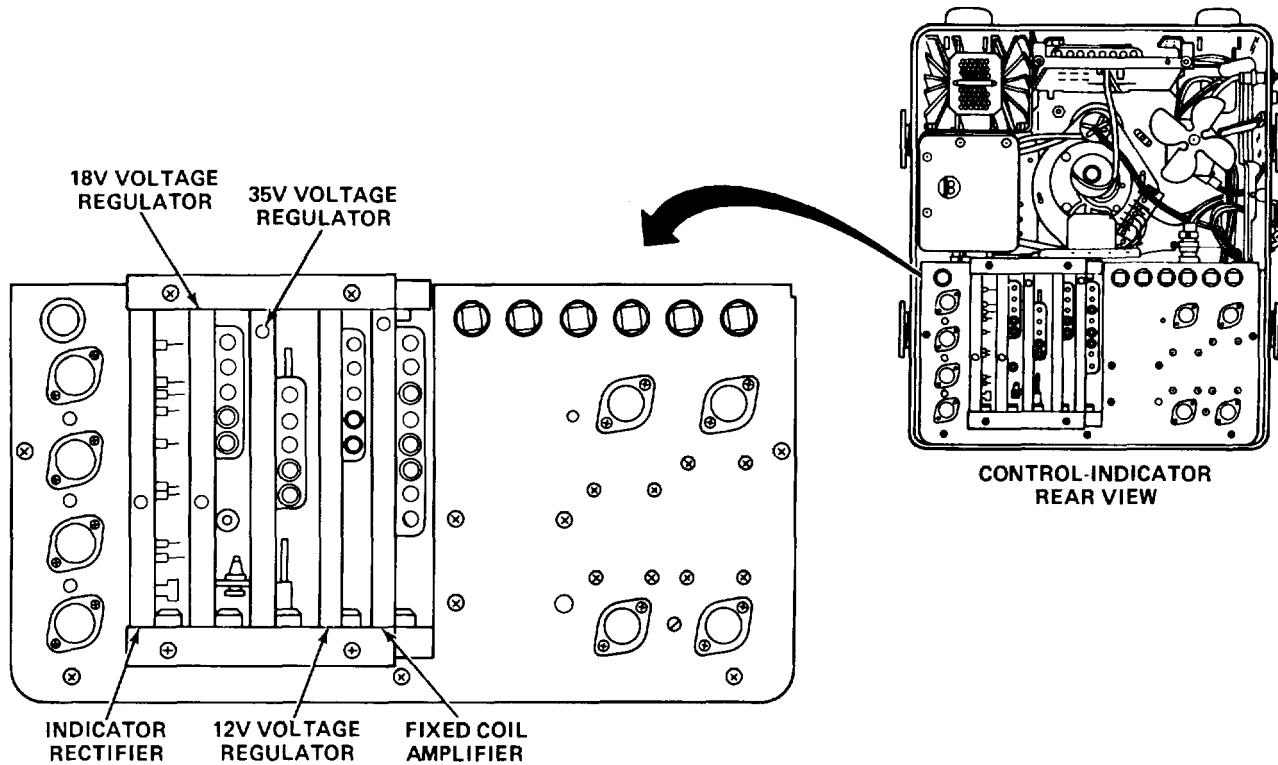

305NE024

The indicator power supply contains five circuit cards that provide the regulated and unregulated dc voltages required by the control-indicator circuits. The five circuit cards are the fixed coil amplifier, 18v voltage regulator, indicator rectifier, 12v voltage regulator, and 35v voltage regulator. The fixed coil amplifier provides the reference voltages to position the time-base sweep horizontally and vertically on the crt. The 18v voltage regulator provides regulator reference signals to the horizontal and vertical series regulators, which in turn supply the regulated - 18v to the horizontal and vertical deflection coils. Unregulated rectified voltages are supplied to the 12 and 35v voltage regulators by the indicator rectifier circuit. The 12v voltage regulator supplies regulator control signals to the 12v series voltage-regulator transistors, which in turn supply the regulated - 12 and + 12 voltages used in the control-indicator circuits. Regulated + 35 and - 35 voltages required by the control-indicator circuits are provided by the 35v series-voltage regulator transistors, which are controlled by regulator reference signals from the 35v voltage regulator. blank)

1-25/ (1-26 blank)

CHAPTER 2

OPERATING INSTRUCTIONS

| Subject | Section | Page |
|--|---------|------|
| Description and Use of Operator's Controls and Indicators | I | 2-1 |
| Operator Preventive Maintenance Checks and Services (PMCS) | II | 2-8 |
| Operation Under Usual Conditions | III | 2-10 |
| Operation Under Unusual Conditions | IV | 2-34 |

Section I DESCRIPTION AND USE OF OPERATOR'S CONTROLS AND INDICATORS

2-1. FUNCTIONS OF CONTROLS, SWITCHES, AND INDICATORS.

RECEIVER-TRANSMITTER

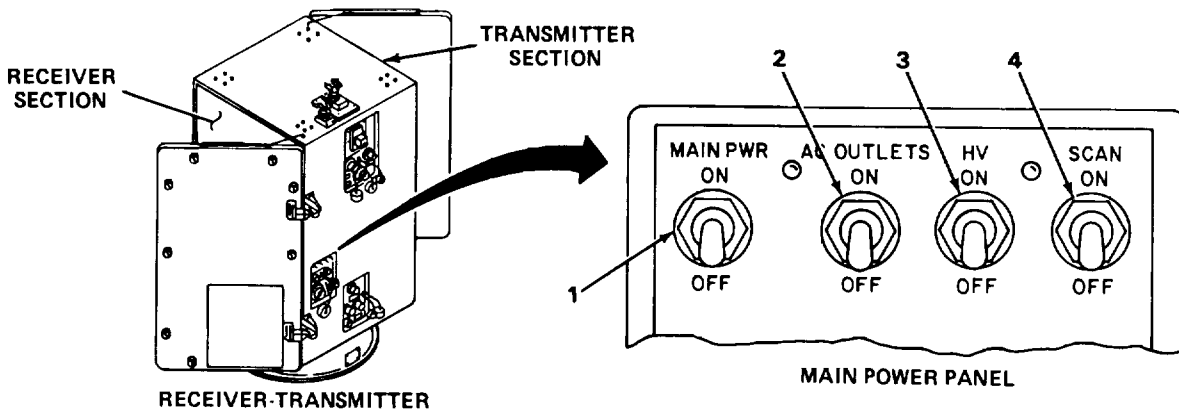

305NE025

| KEY | CONNECTOR | FUNCTION |
|-----|----------------------------|---|
| 1 | MAIN PWR circuit breaker | Applies primary 120 vac, 3-phase, 400 Hz power to receiver-transmitter. |
| 2 | AC OUTLETS circuit breaker | Applies 120 vac, single-phase, 400 Hz power to ac outlets. |
| 3 | HV switch | Applies + 28 v enable voltage to interlock transmitter high-voltage power supply. |
| 4 | SCAN switch | Applies primary ac power to scan drive motors. |

2-1. FUNCTIONS OF CONTROLS, SWITCHES, AND INDICATORS. (CONT)

RECEIVER-TRANSMITTER (CONT)

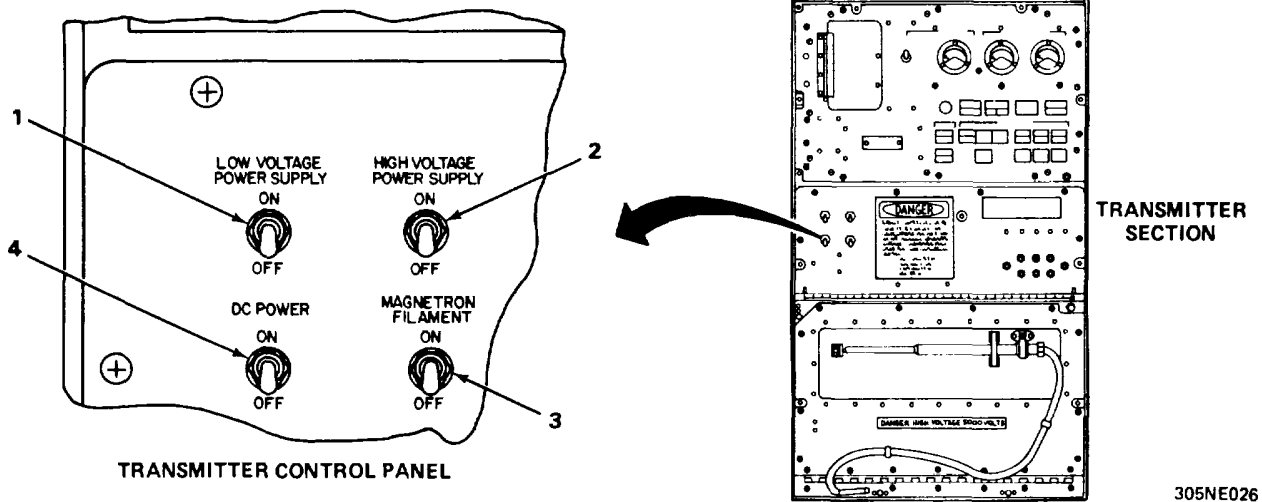

| KEY | CONNECTOR | FUNCTION |
|-----|---|--|
| 1 | LOW VOLTAGE POWER SUPPLY circuit breaker | Applies primary 3-phase ac power to receiver-transmitter low-voltage power supply. |
| 2 | HIGH VOLTAGE POWER SUPPLY circuit breaker | Applies primary 3-phase ac power to transmitter high-voltage power supply. |
| 3 | MAGNETRON FILAMENT circuit breaker | Applies dc voltage from low-voltage power supply to magnetron filament schedule circuit. |
| 4 | DC POWER circuit breaker | Applies + 28 v and - 35 v to system distribution. |

2-1. FUNCTIONS OF CONTROLS. SWITCHES. AND INDICATORS. (CONT)

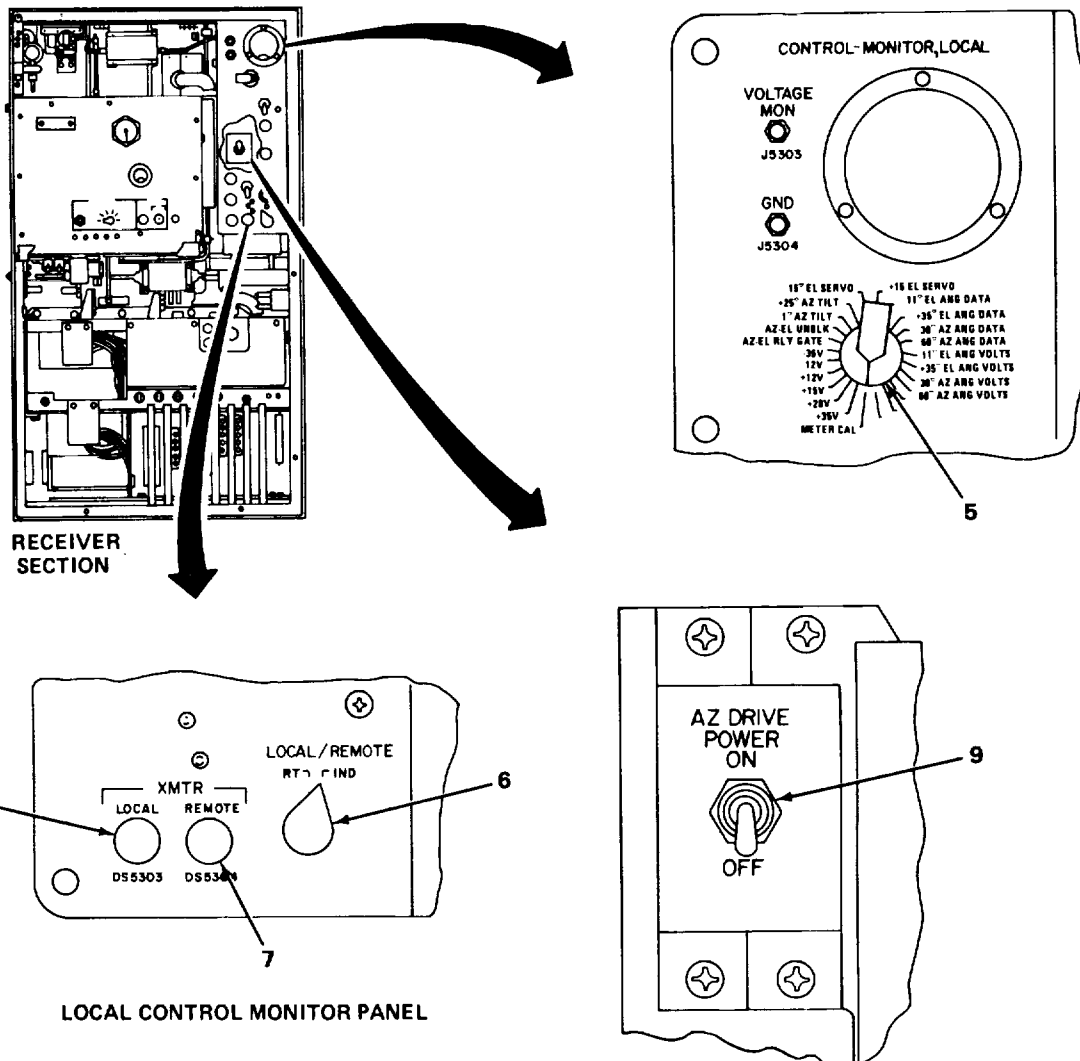

305NE027

| KEY | CONNECTOR | FUNCTION |
|-----|--------------------------------|---|
| 5 | MONITOR switch | Selects receiver-transmitter low-voltage power supply and antenna data to be monitored on meter or between test points J5303 and J5304. |
| 6 | LOCAL/REMOTE switch | Allows control of receiver and antenna scan and polarization functions from either receiver-transmitter or control-indicator. |
| 7 | XMTR REMOTE indicator (DS5304) | Lights when LOCAL/REMOTE switch is in IND position. |
| 8 | XMTR LOCAL indicator (DS5303) | Lights when LOCAL/REMOTE switch is in RT position. |
| 9 | AZ DRIVE POWER circuit breaker | Applies primary 3-phase power to drive power amplifier. |

2-1. FUNCTIONS OF CONTROLS, SWITCHES, AND INDICATORS. (CONT)

PULSE GENERATOR

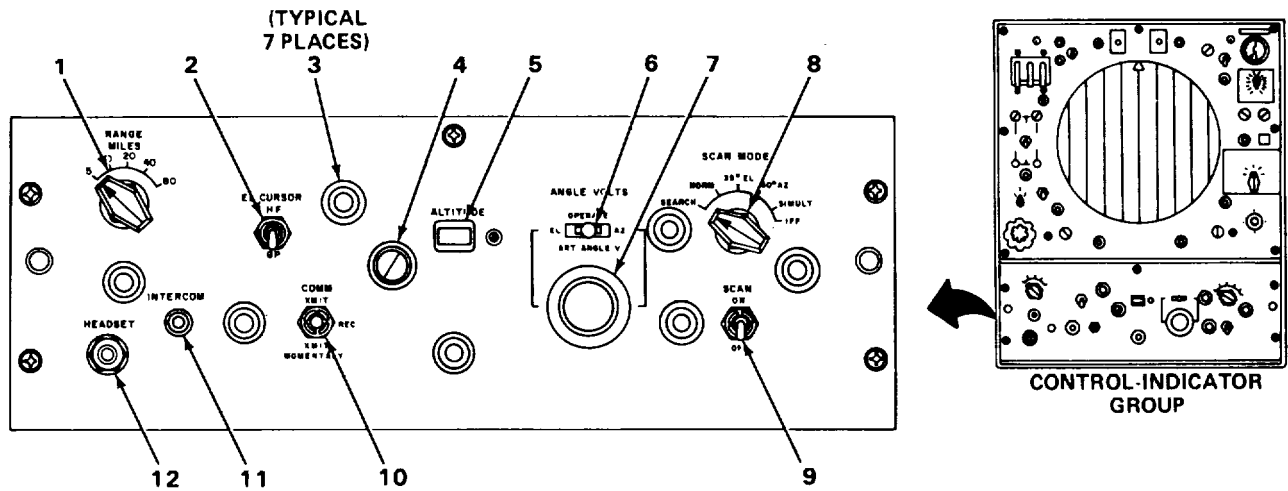

305NE029

| KEY | CONNECTOR | FUNCTION |
|-----|---------------------|--|
| 1 | RANGE MILES switch | Selects radar video ranges 5, 10, 20, and 40 nautical miles. Radar video is not displayed in 80 position. |
| 2 | EL CURSOR switch | Selects cursor on elevation display. |
| 3 | Panel lamp | Illuminates front panel. |
| 4 | Altitude control | Varies height of height finder cursor on elevation display. |
| 5 | ALTITUDE indicator | Displays elevation from 0 to 30,000 feet (in hundreds). |
| 6 | ANGLE VOLTS switch | Selects antenna position (AZ-EL angle voltage). |
| 7 | ART ANGLE V control | Positions azimuth and elevation artificial sweeps. |
| 8 | SCAN MODE switch | Selects scan mode desired. |
| 9 | SCAN switch | Starts or stops antenna scan in any scan mode. |
| 10 | COMM switch | Communication control switch (optional). |
| 11 | INTERCOM switch | Connects HEADSET Jack to receiver and microphone audio lines from communications transceiver or to intercom line from radar set group. |
| 12 | HEADSET jack | Use with combination headset/microphone. |

2-1. FUNCTIONS OF CONTROLS, SWITCHES, AND INDICATORS. (CONT)

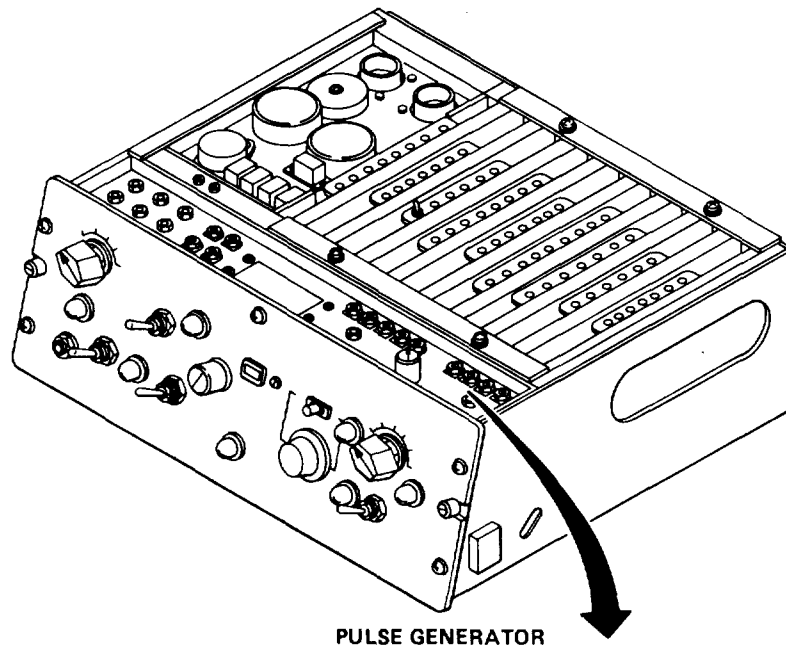

PULSE GENERATOR

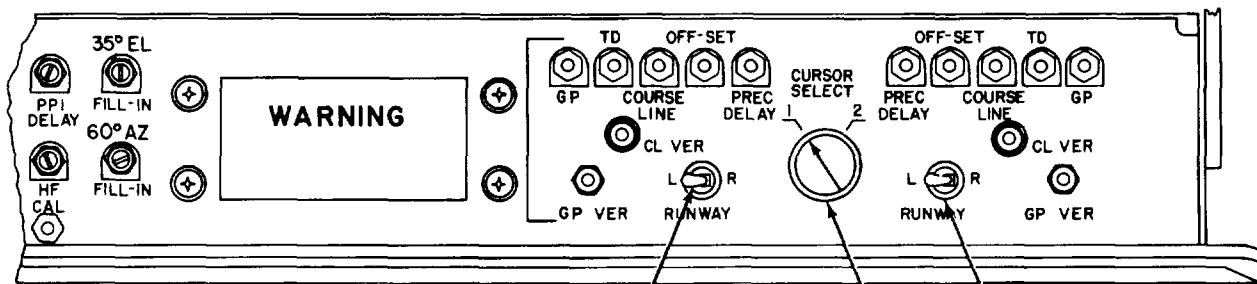

13

14

15

305NE030

| KEY | CONNECTOR | FUNCTION |
|-----|----------------------|--|
| 13 | RUNWAY L-R switch | Transfers azimuth cursor to permit operation from either side of runway when CURSOR SELECT switch is in position 1. |
| 14 | CURSOR SELECT switch | Selects one of two sets of cursors for two different runway approach paths. |
| 15 | RUNWAY L-R switch | Transfers azimuth cursor circuits to permit operation from either side of runway when CURSOR SELECT switch is in position 2. |

2-1. FUNCTIONS OF CONTROLS, SWITCHES, AND INDICATORS. (CONT)

CONTROL-INDICATOR

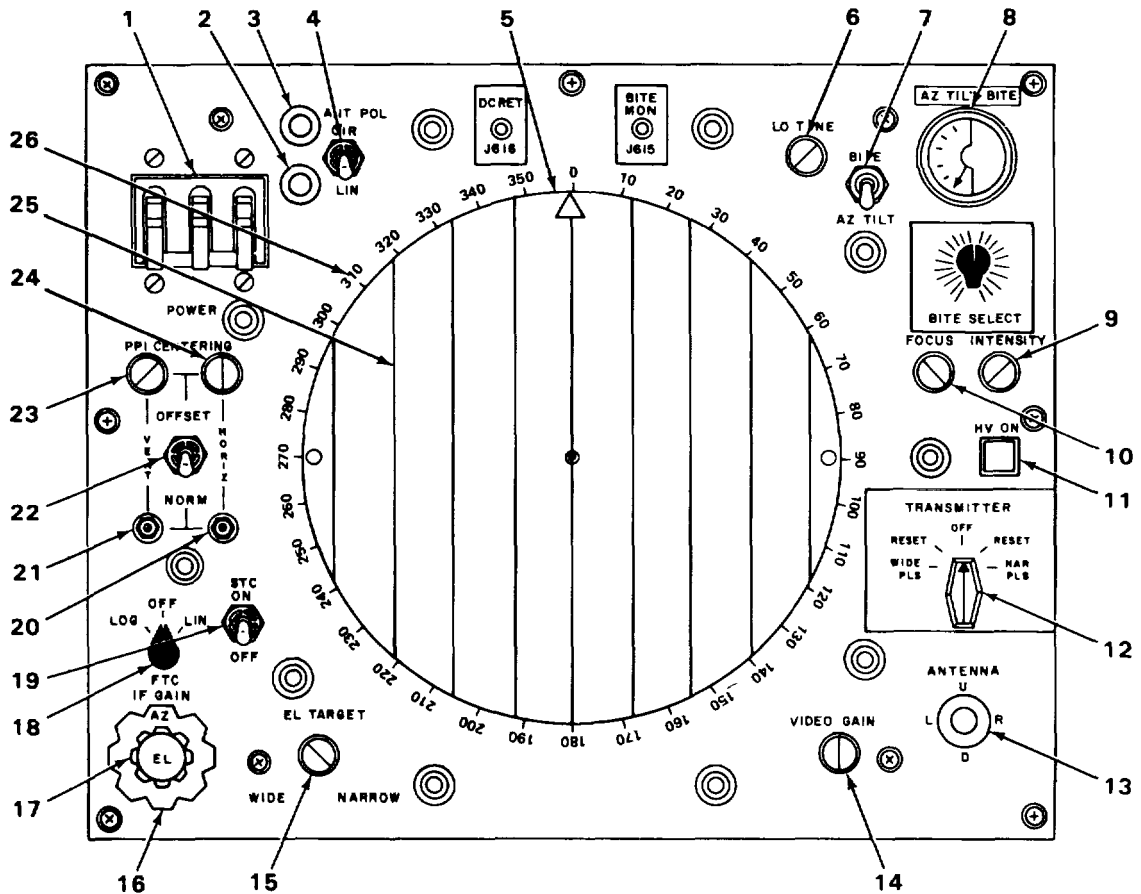

305NE031

| KEY | CONNECTOR | FUNCTION |
|-----|--------------------------------|---|
| 1 | POWER switch (circuit breaker) | Applies power to control-indicator circuits and blower. |
| 2 | Indicator lamp | Lights when ANT POL switch is in LIN position. |
| 3 | Indicator lamp | Lights when ANT POL switch is in CIR position. |
| 4 | ANT POL switch | Selects either circular or linear rf polarization. |
| 5 | CRT | Plan position indicator (radar display indicator). |
| 6 | LO TUNE control | Tunes frequency of local oscillator. |

2-1. FUNCTIONS OF CONTROLS, SWITCHES, AND INDICATORS. (CONT)

| KEY | CONNECTOR | FUNCTION |
|-----|----------------------------------|---|
| 7 | BITE-AZ TILT switch | Provides meter selection to monitor azimuth antenna tilt or BITE (built-in test equipment). |
| 8 | AZ TILT/BITE meter | Provides azimuth antenna tilt information and maintenance control-indicator voltage information. |
| 9 | INTENSITY control | Controls brightness of time-base sweep on display. |
| 10 | FOCUS control | Controls focus of crt electron beam. |
| 11 | HV ON switch/indicator | Controls application of high voltage to transmitter. |
| 12 | TRANSMITTER switch | Selects width of transmitter pulse. |
| 13 | ANTENNA switch | Controls vertical tilt of azimuth antenna and horizontal servo direction of elevation antenna. |
| 14 | VIDEO GAIN control | Controls brightness of video signals on display. |
| 15 | EL TARGET control | Adjusts monopulse operation of receiver. |
| 16 | IF GAIN AZ control | Controls if gain on search and beta azimuth display. |
| 17 | IF GAIN EL control | Controls if gain on beta elevation display. |
| 18 | FTC switch | Controls video output of receiver. |
| 19 | STC switch | Reduce receiver if gain at close ranges. |
| 20 | PPI CENTERING HORIZ control | Controls horizontal position of ppi display when CENTERING NORM-OFFSET switch is in NORM position. |
| 21 | PPI CENTERING VERT control | Controls vertical position of ppi display when CENTERING NORM-OFFSET switch is in NORM position. |
| 22 | PPI CENTERING NORM-OFFSET switch | Selects either normal or offset centering controls. |
| 23 | PPI CENTERING VERT control knob | Controls vertical centering of ppi display when PPI CENTERING NORM-OFFSET switch is in OFFSET position. |
| 24 | PPI CENTERING HORIZ control knob | Controls horizontal centering of ppi display when PPI CENTERING NORM-OFFSET switch is in OFFSET position. |
| 25 | GRID (vector) | Movable grid used to aid operator in selecting a definite bearing on compass rose. |
| 26 | Compass rose | Allows operator to determine aircraft bearing. |

Section II OPERATOR PREVENTIVE MAINTENANCE CHECKS AND SERVICES (PMCS)**2-2. GENERAL.**

To ensure operational readiness of the ANITPN-18A it must be inspected at definite intervals so that defects may be found and corrected before they result in serious damage or failure. The Preventive Maintenance Checks and Services (PMCS) that must be done are listed on page 2-9.

The Preventive Maintenance Checks and Services procedures are required to keep your equipment in good operating condition. They include (B) before operation and (W) weekly checks.

Perform the before operation and weekly checks if you are the assigned operator and have not operated the equipment since the last check, or if you are operating the equipment for the first time.

If the equipment fails to operate, see operator troubleshooting procedures in chapter 3, section I of this manual. Use DA PAM 738-750 as a guide for reporting problems and using forms.

Routine checks like cleaning components, checking for frayed and damaged cables, checking for loose hardware, and corrosion on receptacles and connectors are not listed in the PMCS tables. These checks and time intervals are described in paragraph 3-3. If you find a routine check in the PMCS, it was listed because other operators reported problems with this item.

The ITEM NO. column in the PMCS table is to be used as a source number for the TM number column on DA Form 2404, Equipment Inspection and Maintenance Worksheet, for recording PMCS results.

The EQUIPMENT IS NOT READY/AVAILABLE IF: column tells you why your equipment cannot be used if the ITEM TO BE INSPECTED does not meet PROCEDURE needs.

NOTE

Keep in mind all warnings and cautions when performing PMCS or any routine checks.

If the equipment must be kept in continuous operation, check and service only those items that can be checked and serviced without disturbing operation. Make the complete checks and services when the equipment can be shut down.

When the radar set is operated with Interrogator Set ANITPX-44 as part of Landing Control Central ANITSQ-71 B, refer to TM 11-5895-468-12 and TM 11-5895-474-12 addendum for operator preventive maintenance instructions for equipment that is not a part of Radar Set AN/TPN-18A.

OPERATOR PREVENTIVE MAINTENANCE CHECKS AND SERVICES

B - BEFORE

W - WEEKLY

| ITEM NO. | INTERVAL | | ITEM TO BE INSPECTED PROCEDURE | EQUIPMENT IS NOT READY/AVAILABLE IF: |
|----------|----------|---|---|---|
| | B | W | | |
| 1 | • | | RADAR SET GROUP Check that radar set group is level. Bubble level on top of elevation antenna drive must be centered (para 1-10). | Radar set group not level. |
| 2 | • | | RECEIVER-TRANSMITTER Check that air vent cover at bottom is removed. | Air vent cover not removed. |
| 3 | • | | CONTROL-INDICATOR Perform Preliminary Operating Procedure (para 2-5). Check plan position indicator (ppi) orientation of video display to compass rose ring. Use radar returns from target reflectors or distant objects with known range and bearings from radar site to ensure that indicated bearings of aircraft on ppi display are correct. | Control-indicator fails ppi orientation check. |
| 4 | • | | CONTROL-INDICATOR Perform azimuth, elevation, and height finder cursor alinement checks (para 3-4). | Control-indicator fails cursor alinement checks. |
| 5 | | • | RADAR SET GROUP Check color of three dehydrator cartridges installed in waveguide adapters (para 3-5). | Dessicant shows no traces of blue, or is pink in color. |
| 6 | | • | RADAR SET GROUP Inspect air filters in bottom of receiver-transmitter and in receiver door for dirt or damage. | Dirty or damaged air filters. |
| 7 | | • | CONTROL-INDICATOR GROUP Inspect air filters in bottom left front of both pulse generators (waster and slave) for dirt or damage. | Dirty or damaged air filters. |

Section III OPERATION UNDER USUAL CONDITIONS

| Subject | Para | Page |
|--|------|------|
| Assembly and Preparation for Use | 2-3 | 2-10 |
| Preliminary Control Settings | 2-4 | 2-10 |
| Preliminary Operating Procedure | 2-5 | 2-13 |
| Search Operation | 2-6 | 2-21 |
| Precision Approach Operation | 2-7 | 2-25 |
| Height Finder Operation | 2-8 | 2-28 |
| Simultaneous Mode Operation | 2-9 | 2-29 |
| IFF Operation..... | 2-10 | 2-31 |
| Standby Condition..... | 2-11 | 2-32 |
| Normal Shutdown..... | 2-12 | 2-33 |
| Emergency Shutdown | 2-13 | 2-34 |

2-3. ASSEMBLY AND PREPARATION FOR USE.

All assembly and preparation for use is done by organizational maintenance personnel.

2-4. PRELIMINARY CONTROL SETTINGS.

RECEIVER-TRANSMITTER

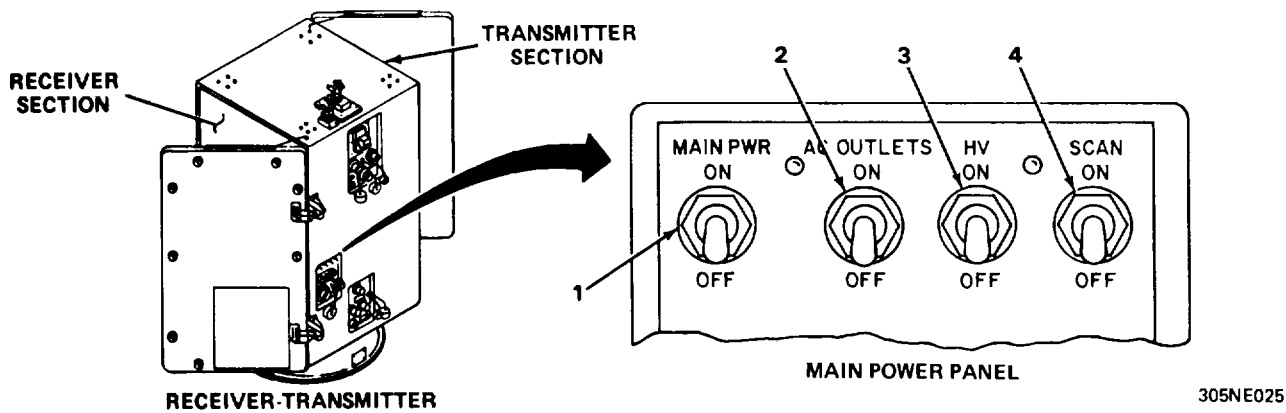

1. Place MAIN PWR circuit breaker (1) to OFF position.
2. Place AC OUTLETS circuit breaker (2) to OFF position.
3. Place HV switch (3) to OFF position.
4. Place SCAN switch (4) to OFF position.

2-4. PRELIMINARY CONTROL SETTINGS. (CONT)

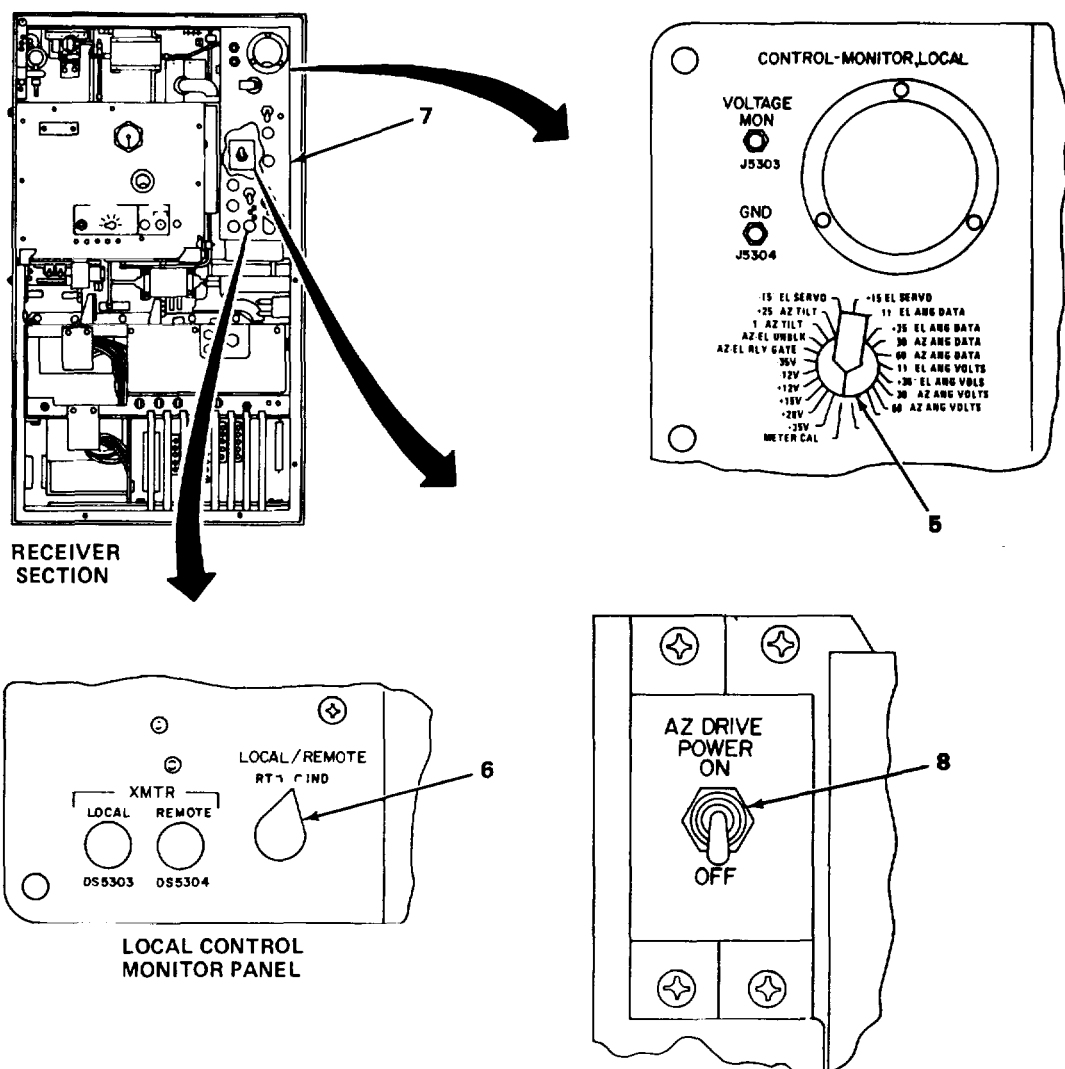

305NE03:

NOTE

Open receiver and transmitter doors to locate switches and circuit breakers for the following Initial adjustments. After completing receiver-transmitter Initial adjustments, be sure to close receiver and transmitter doors.

5. Place MONITOR switch (5) to METER CAL position.
6. Place LOCAUREMOTE switch (6) to IND position.
7. Open local control monitor panel (7).
8. Place AZ DRIVE POWER (8) circuit breaker to OFF.

2-4. PRELIMINARY CONTROL SETTINGS. (CONT)

RECEIVER-TRANSMITTER (CONT)

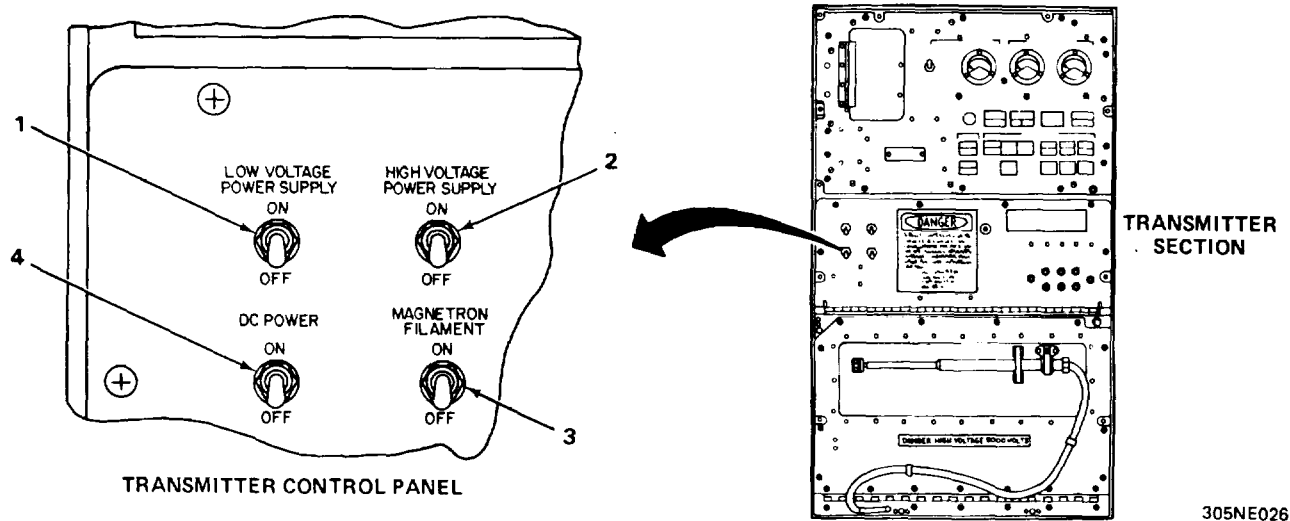

9. Place LOW VOLTAGE POWER SUPPLY circuit breaker (1) to OFF position.
10. Place HIGH VOLTAGE POWER SUPPLY circuit breaker (2) to OFF position.
11. Place MAGNETRON FILAMENT circuit breaker (3) to OFF position.
12. Place DC POWER circuit breaker (4) to OFF position.

CONTROL-INDICATORS

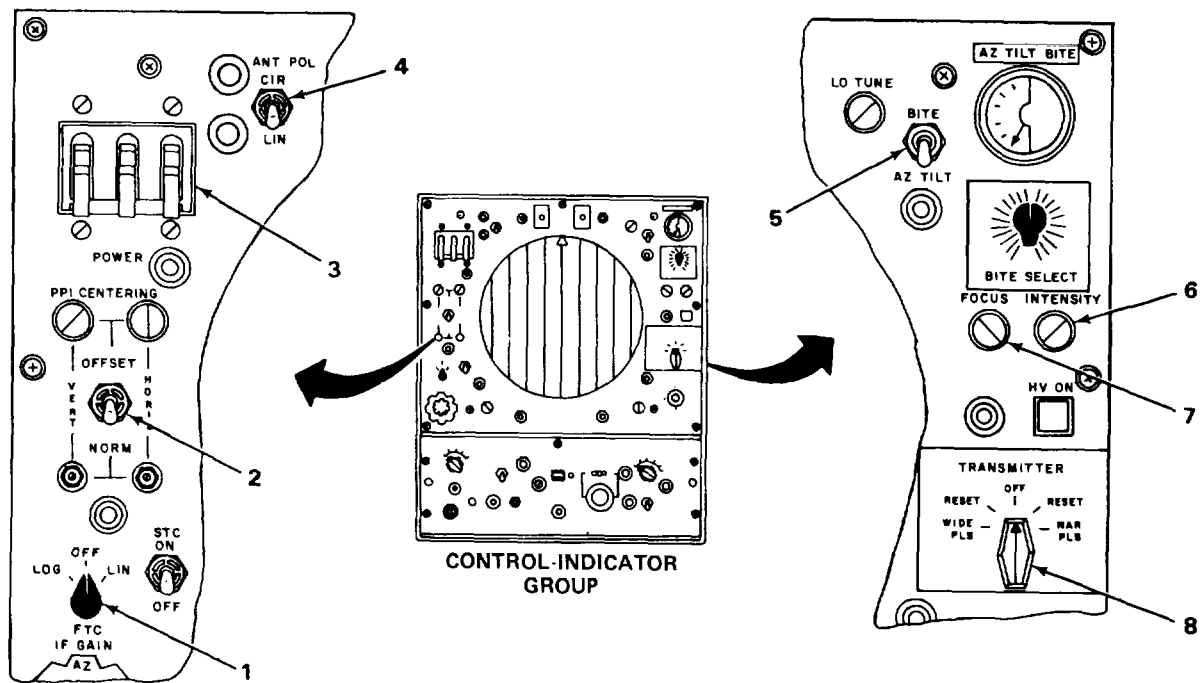

2-4. PRELIMINARY CONTROL SETTINGS. (CONT)

1. Place FTC switch (1) on master control-indicator to OFF position.
2. Place PPI CENTERING NORM-OFFSET switches (2) on both control-indicators to NORM position.
3. Place POWER circuit breakers (3) on both control-indicators to OFF position.
4. Place ANT POL switch (4) on master control-indicator to LIN position.
5. Place BITE-AZ TILT switches (5) on both control-indicators to AZ TILT position.
6. Rotate INTENSITY controls (6) on both control-indicators fully counterclockwise.
7. Rotate FOCUS controls (7) on both control-indicators fully counterclockwise.
8. Place TRANSMITTER switch (8) on master control-indicator to OFF position.

PULSE GENERATOR UNITS

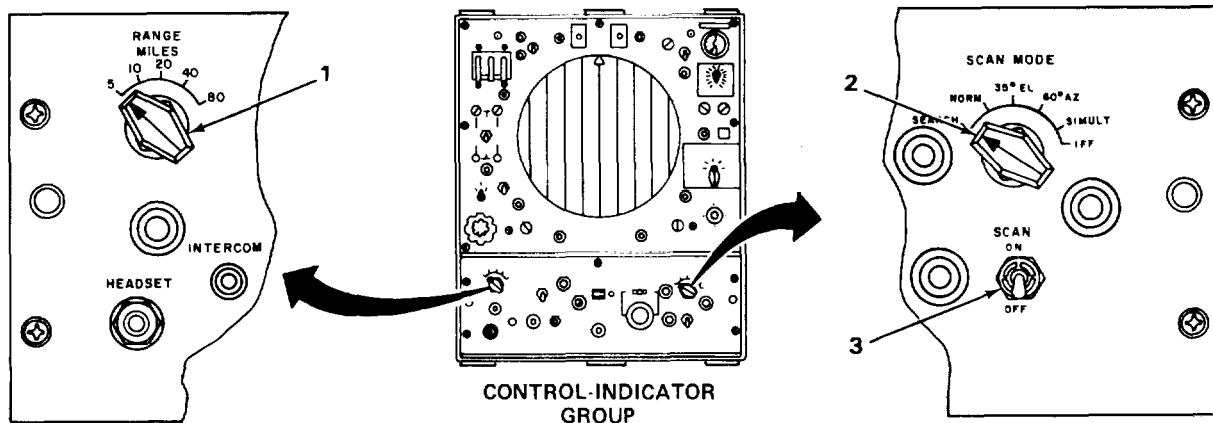

305NE038

1. Place RANGE MILES switch (1) on both pulse generator units in any position except 80.
2. Place SCAN MODE switch (2) on master pulse generator unit in any position except IFF.

WARNING

When used in landing control central systems, the SCAN switch on both pulse generator units must be in OFF position to prevent inadvertent antenna scan operation, and possible injury to personnel.

3. Place SCAN switch (3) on both pulse generator units to OFF position.

2-5. PRELIMINARY OPERATING PROCEDURE.

TURN-ON PROCEDURE

WARNING

Lethal voltages are developed in the receiver-transmitter and control-indicators. Observe safety precautions at all times.

2-5. PRELIMINARY OPERATING PROCEDURE. (CONT)

TURN-ON PROCEDURE (CONT)

CAUTION

Ensure that all controls, switches, and circuit breakers are in the positions indicated in Preliminary Control Settings (para 2-4) before starting the power generator, or damage could result to the radar equipment.

Make sure filter hood on receiver-transmitter is open and red vent covers on control-indicators and receiver-transmitter, along with red cover on azimuth drive reducer, are removed before applying power to the equipment or damage could result to equipment.

NOTE

When radar set is used in conjunction with landing control system shelter, refer to TM 11-5895-474-12 addendum for information on circuit breakers that power the radar set.

RECEIVER-TRANSMITTER

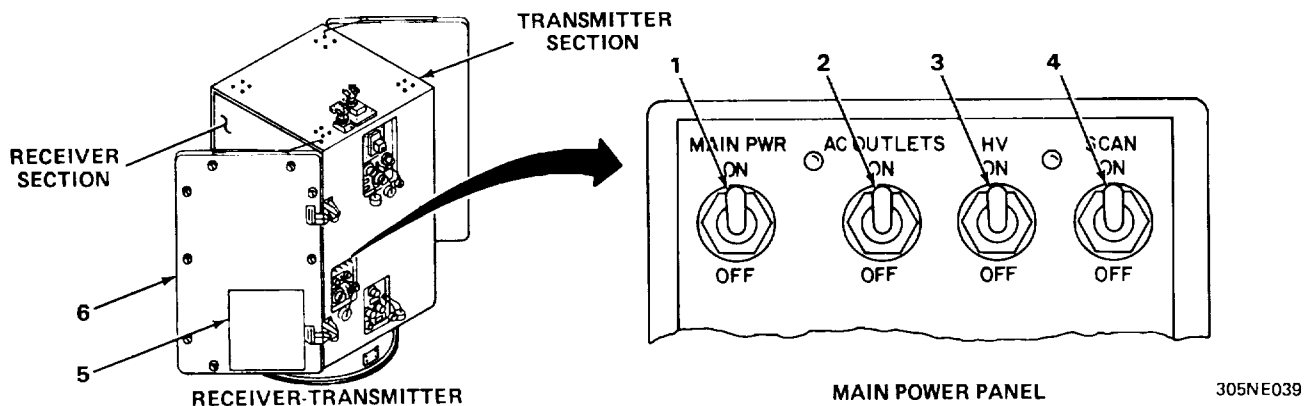

1. Place MAIN PWR circuit breaker (1) to ON position.
2. Place AC OUTLETS circuit breaker (2) to ON position.
3. Place HV switch (3) to ON position.
4. Place SCAN switch (4) to ON position.
5. Open filter hood (5) on receiver door (6).

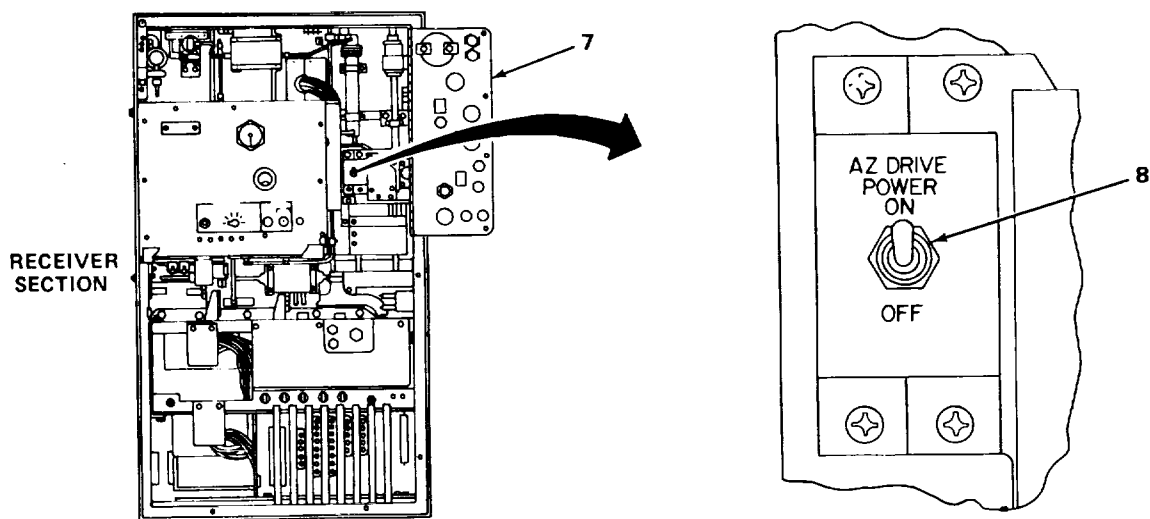

2-5. PRELIMINARY OPERATING PROCEDURE. (CONT)

NOTE

Open receiver and transmitter doors to locate switches and circuit breakers for the following turn-on procedures.

6. Open local control monitor panel (7).
7. Place AZ DRIVE POWER (8) circuit breaker to ON position.
8. Close local control monitor panel (7).

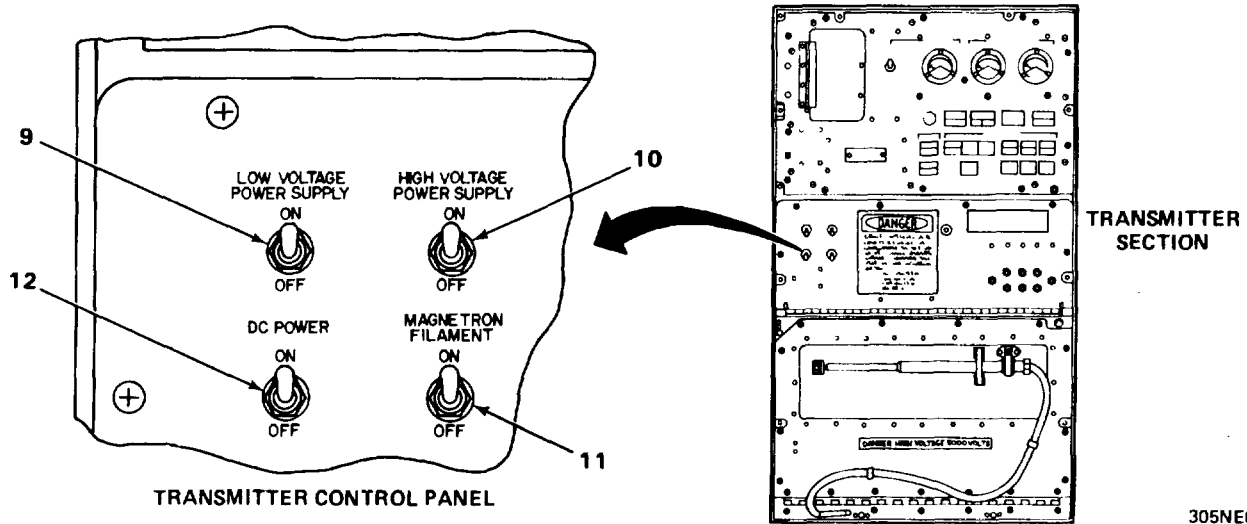

305NE041

9. Place LOW VOLTAGE POWER SUPPLY circuit breaker (9) to ON position.
10. Place HIGH VOLTAGE POWER SUPPLY circuit breaker (10) to ON position.
11. Place MAGNETRON FILAMENT circuit breaker (11) to ON position.
12. Place DC POWER circuit breaker (12) to ON position.

CAUTION

Make sure receiver and transmitter doors are closed and locked before proceeding with the following steps.

2.5. PRELIMINARY OPERATING PROCEDURE. (CONT)

CONTROL-INDICATORS

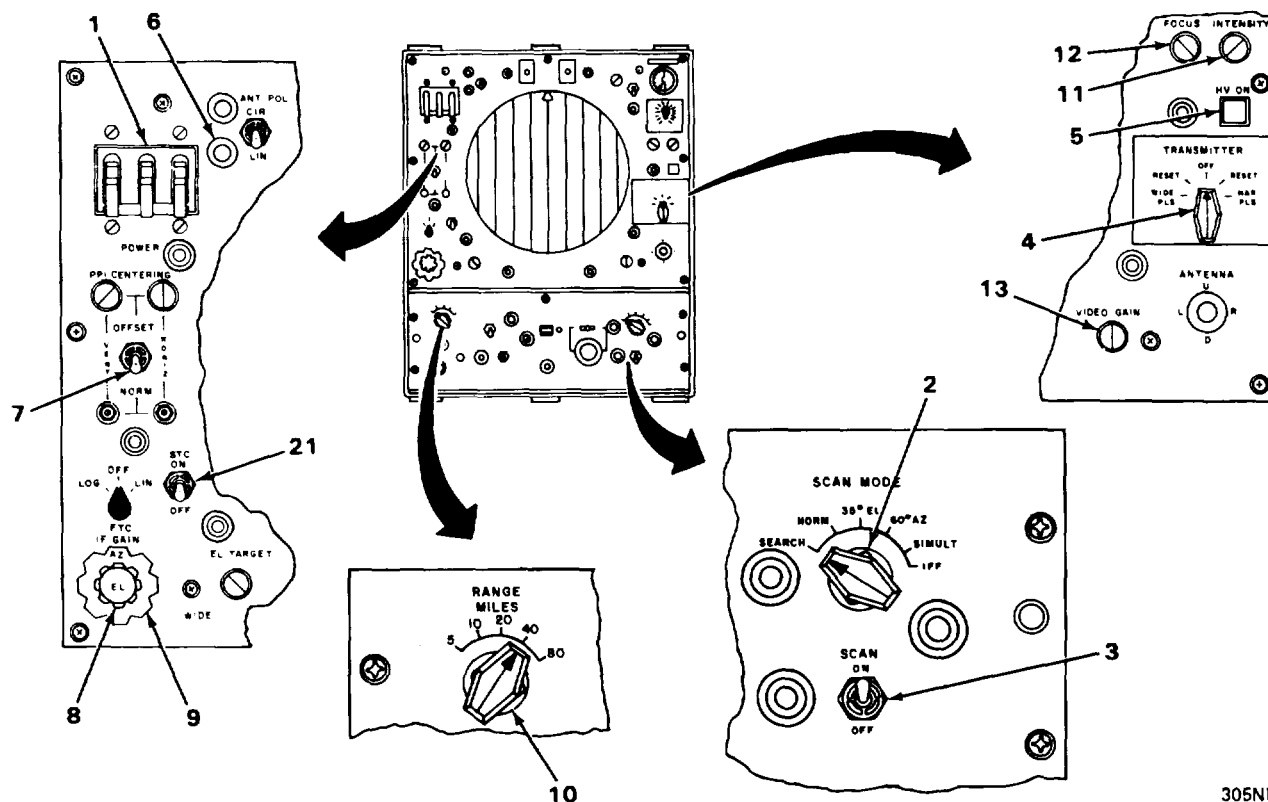

305NE042

CRT Display Adjustments

1. Place POWER circuit breakers (1) on both control-indicators to ON position.
2. Place SCAN MODE switch (2) on master pulse generator to SEARCH position.
3. Place SCAN switch (3) on master pulse generator to ON position.
4. Check that azimuth antenna rotates, then place SCAN switch (3) to OFF position.
5. After 3-minute warmup period, place TRANSMITTER switch (4) on master control-indicator to WIDE PLS position.
6. Press HV ON switch (5) on master control-indicator. The indicator light in both HV ON switches (5) on both control-indicators will light.
7. LIN indicator lights (6) on both control-indicators will light.
8. Place PPI CENTERING NORM-OFFSET switches (7) on both control-indicators to NORM
9. Rotate IF GAIN EL controls (8) on both control-indicators fully counterclockwise.
10. Rotate IF GAIN AZ controls (9) on both control-indicators fully counterclockwise.
11. Place RANGE MILES switches (10) on both pulse generators to 40 position.
12. Place SCAN MODE switches (2) on both pulse generators to SEARCH position.
13. Place SCAN switch (3) on master pulse generator to ON position.
14. Adjust INTENSITY (11) and FOCUS (12) controls for the sharpest trace on both crt displays.
15. Rotate IF GAIN AZ controls (9) on both control-indicators fully clockwise.
16. Rotate VIDEO GAIN controls (13) clockwise until sharpest definition of low-level radar video is obtained on both crt displays.
17. Set VIDEO GAIN controls (13) as high as possible without blooming of video or loss of definition.

2-5. PRELIMINARY OPERATING PROCEDURE. (CONT)

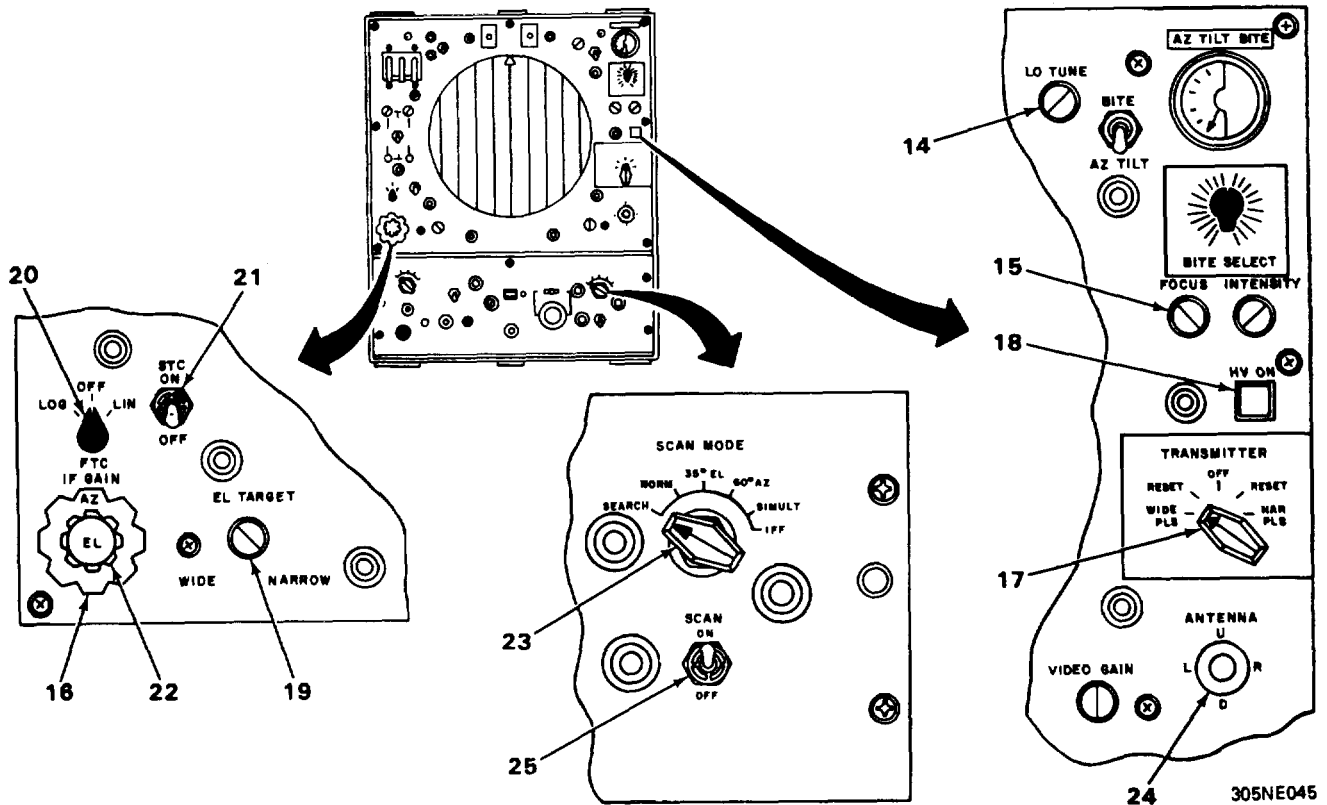

18. Adjust LO TUNE controls (14) to increase radar video.
19. Readjust FOCUS control (15) for best overall definition.
20. To reduce receiver noise (grass) in background, rotate IF GAIN AZ controls (16) slightly counterclockwise.

Tuneup Procedure

Initial tuning of the receiver-transmitter is accomplished by maintenance personnel. By utilizing the controls on the master control-indicator, the operator can make fine tuning adjustments to compensate for frequency drift. The radar set must have been alined by maintenance personnel before performing the tuneup procedure below.

21. Check that TRANSMITTER switch (17) is in WIDE PLS position.
22. Check that HV ON indicator (18) is lit and equipment is stabilized (allow minimum of 2 minutes).
23. Place EL TARGET control (19) to WIDE position.
24. Place FTC switch (20) to OFF position.
25. Place STC switch (21) to OFF position.
26. Rotate IF GAIN AZ control (16) fully clockwise.
27. Rotate IF GAIN EL control (22) fully clockwise.
28. Place SCAN MODE switch (23) to SEARCH position.
29. Place ANTENNA switch (24) to U or D position to obtain any ground return at long range.
30. Place SCAN switch (25) to OFF position, stopping the azimuth antenna on the ground return.
31. Adjust LO TUNE control (14) to obtain maximum ground return signal on crt display.

2-5. PRELIMINARY OPERATING PROCEDURE. (CONT)

Scan and Video Presentation Checks

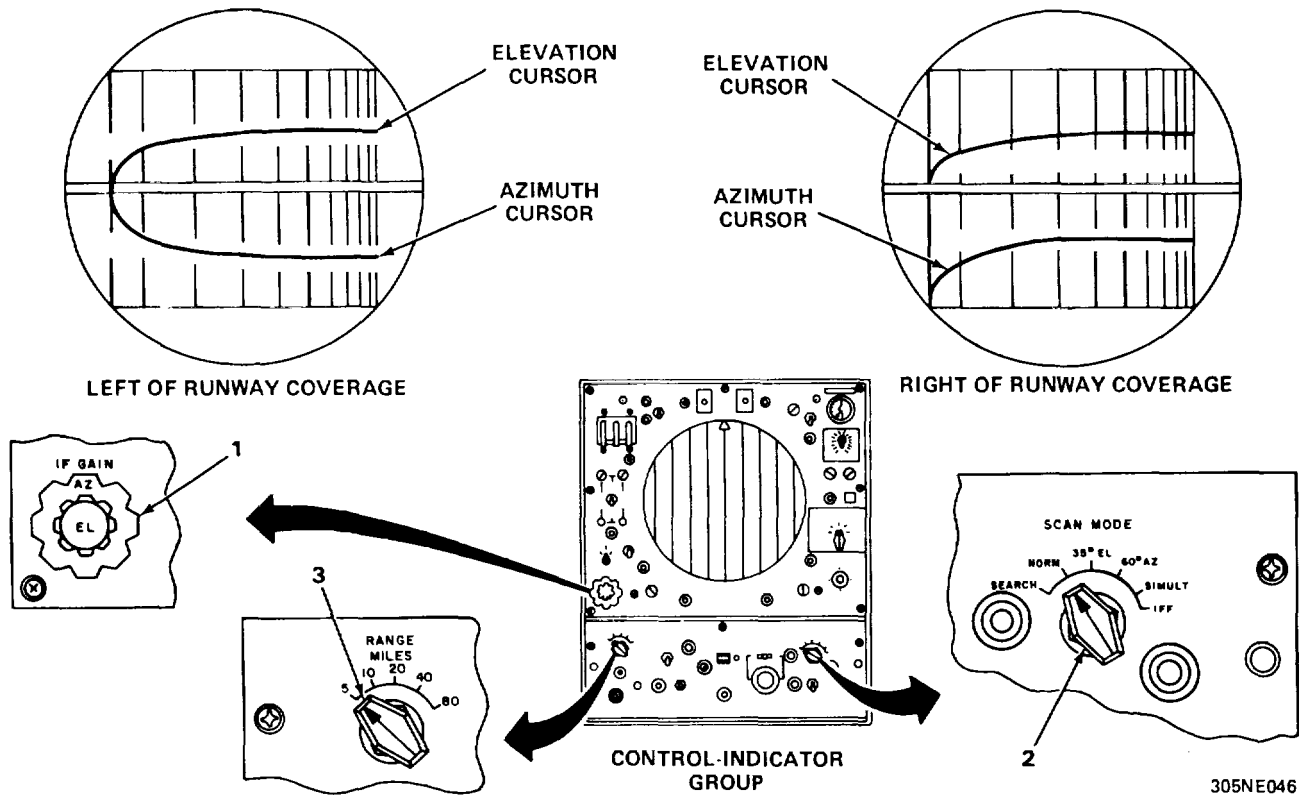

Scan and video presentation checks are made in conjunction with the tuneup procedure in order to ensure optimum operation of the equipment. For right-of-runway coverage, the azimuth cursor will curve down and for left-of-runway coverage, it will curve up. The elevation cursor is turned down in both configurations.

- 32. On master control-indicator, adjust IF GAIN AZ control (1) counterclockwise, as necessary, to maintain the ground return signal as small as possible.

NOTE

Refer to the table on pages 2-19 through 2-21 when performing step 33.

- 33. On master and slave pulse generators, place SCAN MODE (2) and RANGE MILES (3) switches to the positions indicated in the SWITCH POSITIONS columns. The DISPLAYED DATA columns indicate the type of scan (beta or ppi) and the type of video (radar and/or IFF) that will be seen on the crt displays when switches are in the positions indicated.

2-5. PRELIMINARY OPERATING PROCEDURE. (CONT)

| SWTICH POSITIONS | | | | DISPLAYED DATA | | | | | |
|------------------|---------------------|-------------|---------------------|----------------|-------|-----|-------|-------|-----|
| MASTER | | SLAVE | | MASTER | | | SLAVE | | |
| SCAN MODE | RANGE MILES | SCAN MODE | RANGE MILES | SCAN | RADAR | IFF | SCAN | RADAR | IFF |
| SEARCH | 5, 10, 20, OR 40 | Any but IFF | 5, 10, 20, OR 40 | PPI | X | X | PPI | X | X |
| NORM | 5,10, 20, OR40 | Any but IFF | 5,10, 20, OR40 | BETA | X | | BETA | X | |
| 35°EL | 5, 10, 20, OR40 | Any but IFF | 5,10, 20, OR40 | BETA | X | | BETA | X | |
| 60°AZ | 5,10, 20, OR40 | Any but IFF | 5,10, 20, OR40 | BETA | X | | BETA | X | |
| SIMULT | 5,10, 20, OR40 | Any but IFF | 5,10, 20, OR40 | BETA | X | | PPI | X | X |
| IFF | 5,10, 20, OR40 | Any but IFF | 5,10, 20, OR40 | PPI | | X | PPI | X | X |
| IFF | 5,10,20, OR40 | IFF | 5,10, 20, OR40 | PPI | | X | PPI | | X |
| SIMULT | 5,10,20, OR40 | IFF | 5,10,20, OR40 | BETA | X | | PPI | | X |
| 60°AZ | 5,10,20, OR40 | IFF | 5,10,20, OR40 | BETA | X | | PPI | | X |
| 35°EL | 5,10, 20, OR40 | IFF | 5,10, 20, OR40 | BETA | X | | PPI | | X |
| NORM | 5,10, 20, OR40 | IFF | 5,10, 20, OR40 | BETA | X | | PPI | | X |
| SEARCH | 5,10, 20, OR40 | IFF | 5,10, 20, OR40 | PPI | X | X | PPI | | X |
| SEARCH | 5,10, 20, OR 40 | IFF | 80 OR 40 | PPI | X | X | PPI | | X |
| NORM | 5,10, 20, OR 40 | IFF | 80 | BETA | X | | PPI | | X |
| 35°EL | 5,10,20, OR 40 | IFF | 80 | BETA | X | | PPI | | X |
| 60°AZ | 5,10,20, OR 40 | IFF | 80 | BETA | X | | PPI | | X |
| SIMULT | 5,10,20, OR 40 | IFF | 80 | BETA | X | | PPI | | X |
| IFF | 5,10, 20, OR 40 | IFF | 80 | PPI | | X | PPI | | X |
| IFF | 5,10, 20, OR 40 | Any but IFF | 80 | PPI | | X | PPI | | X |
| SIMULT | 5,10, 20, OR40 | Any but IFF | 80 | BETA | X | | PPI | | X |

2-5. PRELIMINARY OPERATING PROCEDURE. (CONT)

| SWTICH POSITIONS | | | | DISPLAYED DATA | | | | | |
|------------------|---------------------|-------------|---------------------|----------------|-------|-----|-------|-------|-----|
| MASTER | | SLAVE | | MASTER | | | SLAVE | | |
| SCAN MODE | RANGE MILES | SCAN MODE | RANGE MILES | SCAN | RADAR | IFF | SCAN | RADAR | IFF |
| 60°AZ | 5,10, 20, OR 40 | Any but IFF | 80 | BETA | X | | BETA | | |
| 350EL | 5, 10, 20, OR 40 | Any but IFF | 80 | BETA | X | | BETA | | |
| NORM | 5, 10, 20, OR 40 | Any but IFF | 80 | BETA | X | | BETA | | |
| SEARCH | 5,10, 20, OR 40 | Any but IFF | 80 | PPI | X | X | PPI | | X |
| SEARCH | 80 | Any but IFF | 80 | PPI | X | PPI | | | X |
| NORM | 80 | Any but IFF | 80 | BETA | | | BETA | | |
| 35°EL | 80 | Any but IFF | 80 | BETA | | | BETA | | |
| 60°AZ | 80 | Any but IFF | 80 | BETA | | | BETA | | |
| SIMULT | 80 | Any but IFF | 80 | BETA | | | PPI | | X |
| IFF | 80 | Any but IFF | 80 | PPI | | X | PPI | | X |
| IFF | 80 | Any but IFF | 5,10, 20, OR 40 | PPI | | X | PPI | X | X |
| SIMULT | 80 | Any but IFF | 5,10, 20, OR 40 | BETA | | | PPI | X | X |
| 60°AZ | 80 | Any but IFF | 5,10,20, OR 40 | BETA | | | BETA | X | |
| 35°EL | 80 | Any but IFF | 5,10, 20, OR 40 | BETA | | | BETA | X | |
| NORM | 80 | Any but IFF | 5, 10, 20, OR 40 | BETA | | | BETA | X | |
| SEARCH | 80 | Any but IFF | 5,10,20, OR 40 | PPI | | X | PPI | X | X |
| SEARCH | 80 | IFF | 5, 10, 20, OR40 | PPI | | X | PPI | | X |
| NORM | 80 | IFF | 5,10, 20, OR 40 | BETA | | | PPI | | X |
| 35°EL | 80 | IFF | 5,10, 20, OR 40 | BETA | | | PPI | | X |
| 60°AZ | 80 | IFF | 5,10, 20, OR 40 | BETA | | | PPI | | X |
| SIMULT | 80 | IFF | 5,10, 20, OR 40 | BETA | | | PPI | | X |
| IFF | 80 | IFF | 5,10, 20, OR 40 | PPI | | X | PPI | | X |

2.5. PRELIMINARY OPERATING PROCEDURE. (CONT)

| SWTICH POSITIONS | | | | DISPLAYED DATA | | | | | |
|------------------|-------------|-----------|-------------|----------------|-------|-----|-------|-------|-----|
| MASTER | | SLAVE | | MASTER | | | SLAVE | | |
| SCAN MODE | RANGE MILES | SCAN MODE | RANGE MILES | SCAN | RADAR | IFF | SCAN | RADAR | IFF |
| IFF | 80 | IFF | 80 | PPI | | X | PPI | | X |
| SIMULT | 80 | IFF | 80 | BETA | | | PPI | | X |
| 60°AZ | 80 | IFF | 80 | BETA | | | PPI | | X |
| 35°EL | 80 | IFF | 80 | BETA | | | PPI | | X |
| NORM | 80 | IFF | 80 | BETA | | | PPI | | X |
| SEARCH | 80 | IFF | 80 | PPI | | X | PPI | | X |

2-6. SEARCH OPERATION.

SEARCH MODE

The search mode of operation locates aircraft within a 40-nautical-mile radius of the airfield and is capable of displaying IFF information within an 80-nautical-mile radius of the airfield when used in conjunction with Interrogator Set ANITPX-44. In the search mode, the operator can select display ranges of 5, 10, 20, and 40 nautical miles that provide range and bearing information necessary to direct the aircraft into position for making a precision (gca) approach. An 80-nautical-mile range displays IFF video only. Range marks of 1, 5, or 10 miles are displayed when RANGE MILES switch is positioned to select range display. A 30-degree sector of the range marks is blanked to present alignment position of the precision approach path. The azimuth antenna may be tilted to + 25 degrees for high-altitude coverage.

SIMULT mode is not used when only one control-indicator is used during the operation of the radar set. When operating in SIMULT mode, the slave control-indicator will have search control of aircraft (ppi presentation). During final approach, control of aircraft will pass to the master control-indicator that has beta presentation in SIMULT mode.

2-8. SEARCH OPERATION. (CONT)

SEARCH MODE (CONT)

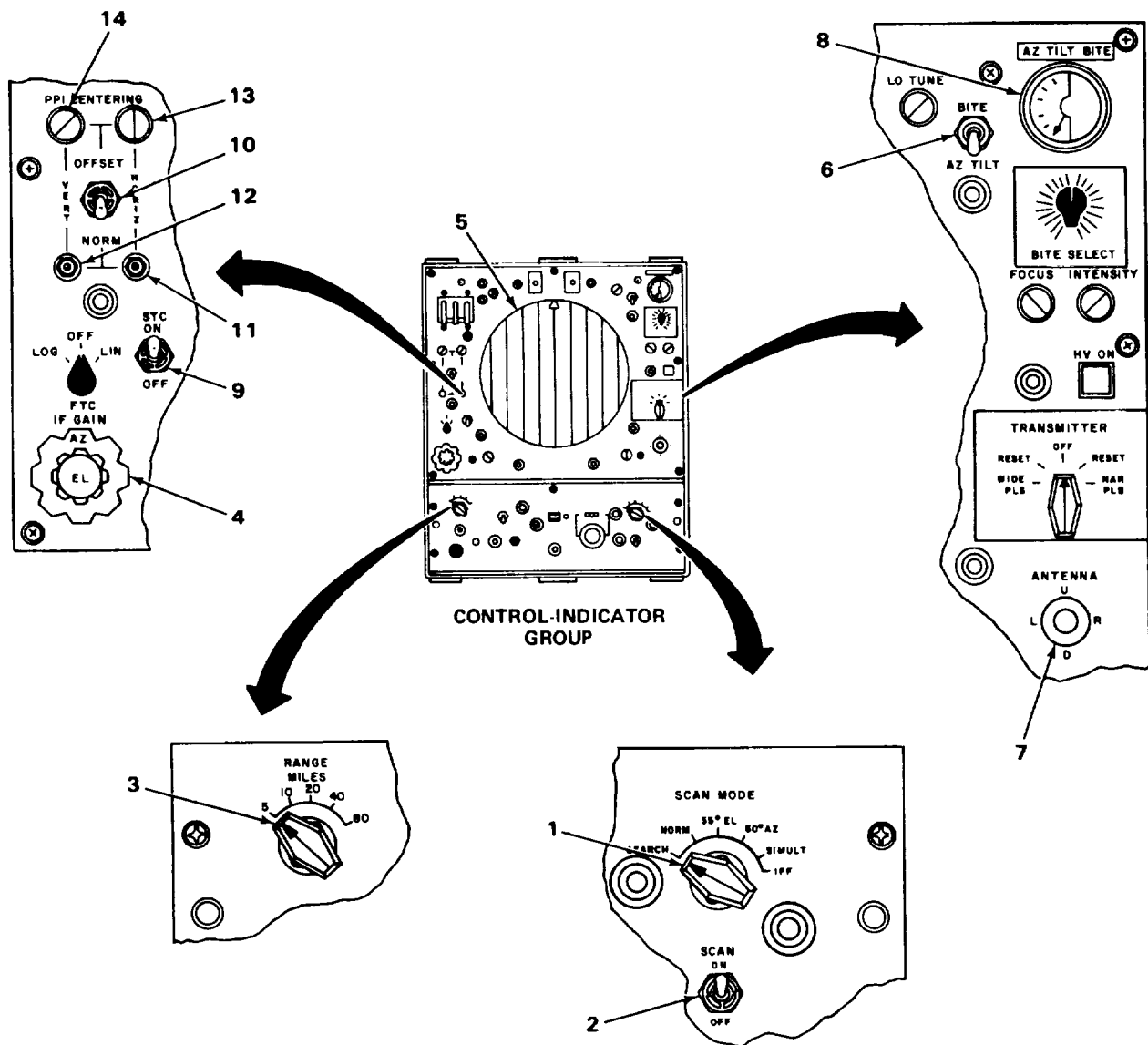

305NE047

Operation in SIMULT mode is explained in Simultaneous Mode Operation (para 2-9). The following instructions will explain the use of one control-indicator for search operation.

NOTE

When not In operation, perform Preliminary Control Settings (para 2-4) and Preliminary Operating Procedure (para 2-5), omitting scan and video presentation checks, to place the radar set in operation.

2-4. SEARCH OPERATION. (CONT)

1. Place SCAN MODE switch (1) to SEARCH position.
2. Place SCAN switch (2) to ON position.
3. Place RANGE MILES switch (3) to any desired position.
4. Adjust IF GAIN AZ control (4) clockwise until receiver noise (grass) is visible in background of crt display (5).
5. Place BITE-AZ TILT switch (6) to AZ TILT position.
6. Place ANTENNA switch (7) in either U or D position to adjust angle of the azimuth antenna.
7. Monitor the tilt angle of the azimuth antenna on AZ TILT/BITE meter (8).
8. When necessary, place STC switch (9) to ON position to reduce the amplitude of return signals at close range.

CENTERING VIDEO DISPLAY

1. Place PPI CENTERING NORM-OFFSET switch (10) to NORM position.
2. Adjust PPI CENTERING HORIZ control (11) to center display horizontally.
3. Adjust PPI CENTERING VERT control (12) to center display vertically.

OFFSETTING VIDEO DISPLAY

Use offset centering feature to extend the range when greater radar video resolution is desired at or near maximum range of display. To offset center of crt display (5), perform the following.

1. Place PPI CENTERING NORM-OFFSET switch (10) to OFFSET position.
2. Adjust PPI CENTERING HORIZ control knob (13) to position display horizontally.
3. Adjust PPI CENTERING VERT control knob (14) to position display vertically.
4. Place PPI CENTERING NORM-OFFSET switch (10) to NORM position after the display is offset.

VIDEO CLUTTER

Video clutter is a blanketing effect displayed on the crt display caused by radar return signals from objects other than the target being tracked. Clutter can be caused by nearby large objects or distant terrain (ground returns) and rain, snow, or fog (precipitation). When tracking through video clutter, care should be exercised when using the controls and switches, so that the return signal from the target being tracked is not lost. Range of target and amount of clutter have to be taken into consideration when selecting the controls to track the target. It is at the discretion of the operator to select the controls that best suit his or her needs. Examples of video clutter that may be encountered during search operation and ways to reduce it are shown on the following page.

2-6. SEARCH OPERATION. (CONT)

VIDEO CLUTTER (CONT)

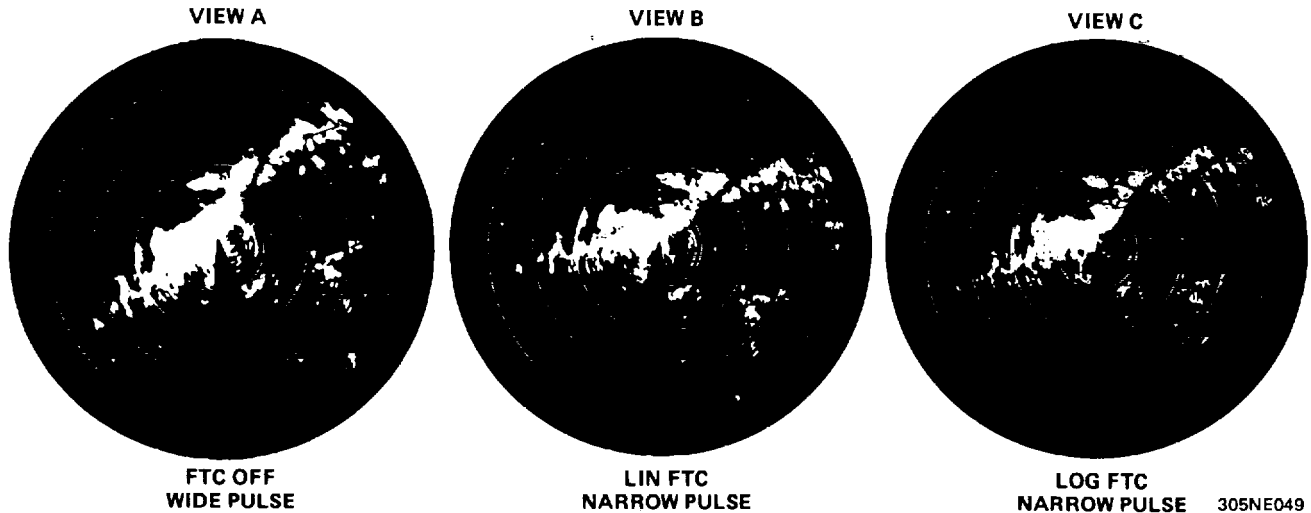

1. View A exhibits a typical display of heavy video clutter that may exist on the crt display when FTC switch is in OFF position and TRANSMITTER switch is in WIDE PLS position. The clutter could obscure return signal from target being tracked.
2. View B exhibits clutter being reduced after placing FTC switch to LIN position and TRANSMITTER switch to NAR PLS position. When FTC switch is in LIN position, receiver if signal is amplified linearly
3. View C exhibits clutter being further reduced after placing FTC switch to LOG position and TRANSMITTER switch remaining in NAR PLS position. When FTC switch is in LOG position, receiver if signal is amplified logarithmically. LOG FTC is used to reduce return clutter (noise) from precipitation.

REDUCING VIDEO CLUTTER FROM GROUND RETURNS AND PRECIPITATION

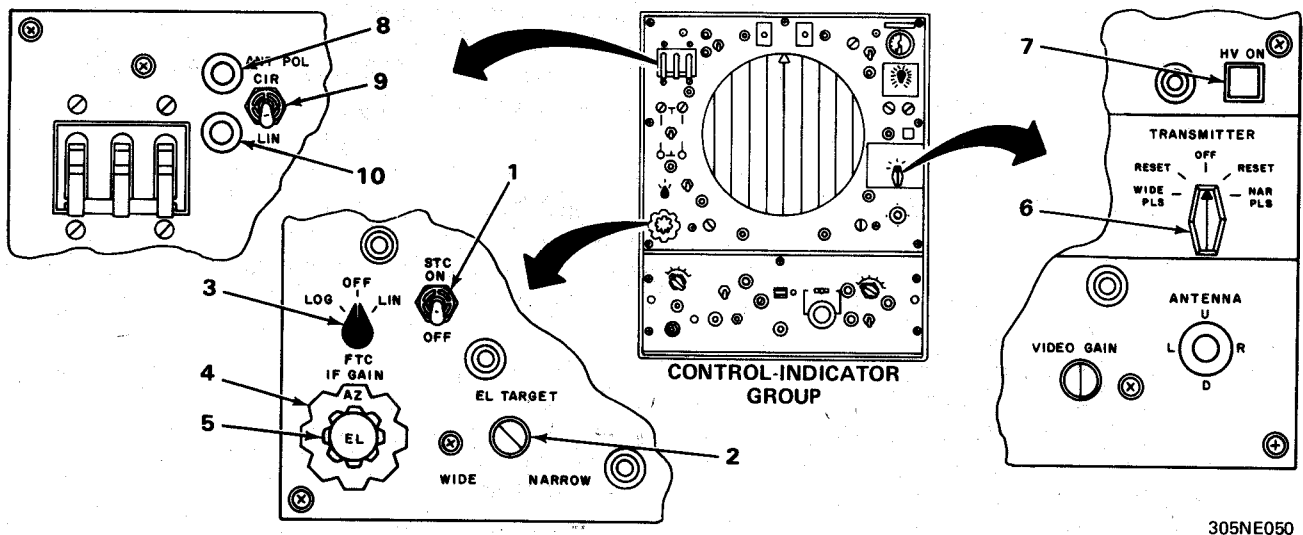

2-4. SEARCH OPERATION. (CONT)

Although there is no definite way for the operator to determine if video clutter is being caused by ground returns or precipitation, there are a number of actions that can be taken to reduce clutter. If clutter is being caused by ground returns, perform steps 1 through 6 in the order of sequence until return signal from target being tracked can be readily followed on the crt. When clutter is being caused by precipitation, or when steps 1 through 5 do not satisfactorily reduce clutter, proceed with steps 7 through 10 in the order of sequence until return signal from target being tracked can be readily followed.

1. Place STC switch (1) to ON position.
2. Rotate EL TARGET control (2) clockwise from WIDE to NARROW position.
3. Place FTC switch (3) to LIN position.
4. Taking care not to lose target, rotate IF GAIN AZ (4) and IF GAIN EL (5) counterclockwise.
5. Place TRANSMITTER switch (6) to NAR PLS position.
6. Press HV ON indicator switch (7).
7. Place STC switch (1) to OFF position.
8. Place FTC switch (3) to LOG position.
9. Rotate IF GAIN AZ (4) and IF GAIN EL (5) controls fully clockwise (maximum gain).

NOTE

When ANT POL switch is placed in CIR position, maximum detection range is reduced approximately 20 percent. Return to LIN position when no longer required.

10. Place ANT POL switch (8) to CIR position. CIR indicator (9) will light and LIN indicator (10) will extinguish.

2-7. PRECISION APPROACH OPERATION.

The precision approach function is used to control aircraft along a courseline and glidepath to the prescribed gca minimums, or theoretically to within 20 feet of runway touchdown. This is accomplished with the SCAN MODE switch on the master control-indicator in NORM 350 EL, 600 AZ, or SIMULT positions. The precision approach display is a dual scan (beta) type. Ranges of 5, 10, 20, and 40 nautical miles, with range marks at 1-mile intervals for 5- and 10-mile ranges and 5 miles for ranges of 20 and 40 miles, can be selected by positioning the RANGE MILES switch. Two sets of preset electronic cursors are available on the azimuth and elevation displays, providing separate glidepath and courseline indications for each of two runway approaches. For right-of-runway coverage, the azimuth cursor will curve down and for left-of-runway coverage, it will curve up. The elevation cursor is turned down in both configurations.

By positioning the SCAN MODE switch to NORM, 350 EL, or 600 AZ positions, azimuth sectors of 30 and 60 degrees may be scanned. The precision approach is accomplished with the master control-indicator. When operating in SIMULT mode, the slave control-indicator crt display will have a ppi scan with IFF video capability. Simultaneous Mode Operation is explained in paragraph 2-9.

2.7. PRECISION APPROACH OPERATION. (CONT)

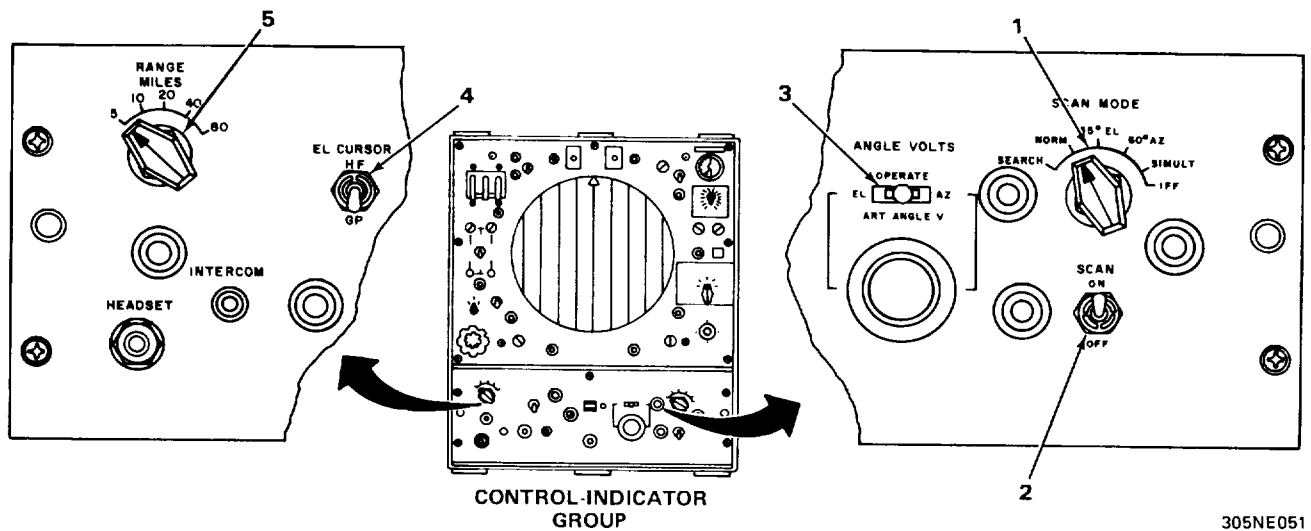

305NE051

NOTE

During operation in SIMULT mode, use care when operating controls and switches on master control-indicator. Their operation controls data going to the slave control- indicator.

Maximum signal returns should exist when blanked range mark sector on the crt display brackets the signal returns from the radar targets adjacent to the runway. For additional information, refer to Cursor Alinement Checks (para 3-4).

When not in operation, perform Preliminary Control Settings (para 2-4) and Preliminary Operating Procedure (para 2-5), omitting scan and video presentation checks, to place the radar set in operation.

1. Place SCAN MODE switch (1) to NORM position.
2. Place SCAN switch (2) to ON position.
3. Place ANGLE VOLTS switch (3) to OPERATE position.
4. Place EL CURSOR switch (4) to GP position.
5. Place RANGE MILES switch (5) to any desired position except 80.

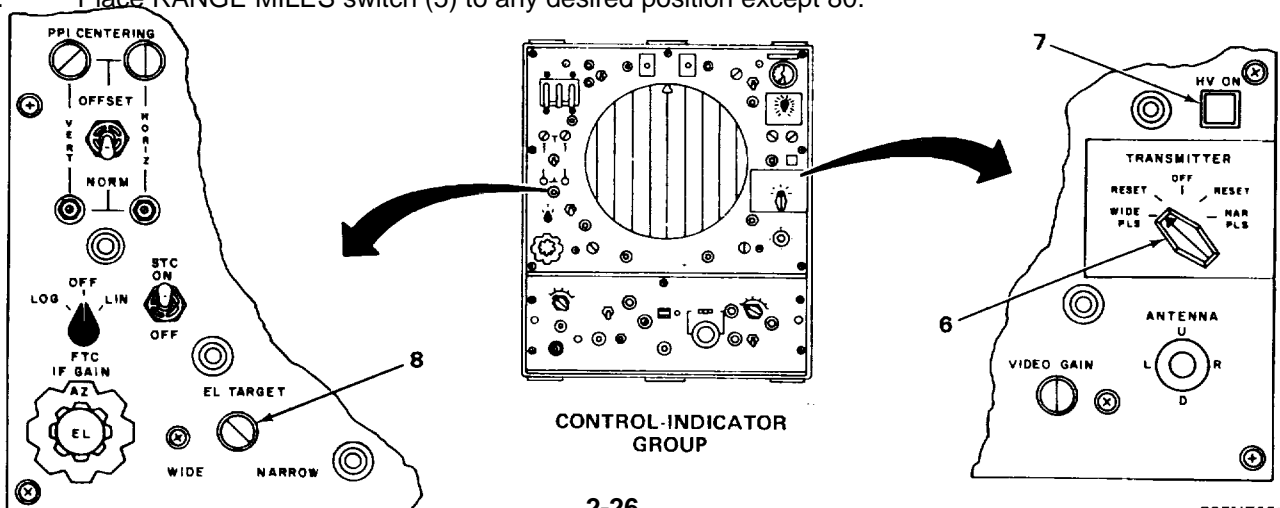

305NE052

2-7. PRECISION APPROACH OPERATION. (CONT)

6. Place TRANSMITTER switch (6) to WIDE PLS position.
7. Press HV ON switch (7). The indicator light in the switch will light.
8. Rotate EL TARGET control (8) fully counterclockwise to WIDE position.

VIDEO CLUTTER

During the precision approach mode of operation, video clutter will be caused by nearby large objects and distant terrain (ground returns). Clutter due to precipitation will also add to the problem of tracking an aircraft when landing. Examples of video clutter and ways to reduce it are shown on the following page. The operator should utilize the controls that best suit his or her needs.

NOTE

Procedures for reducing video clutter due to ground returns and precipitation are given in Search Operation, Reducing Video Clutter (para 2-6).

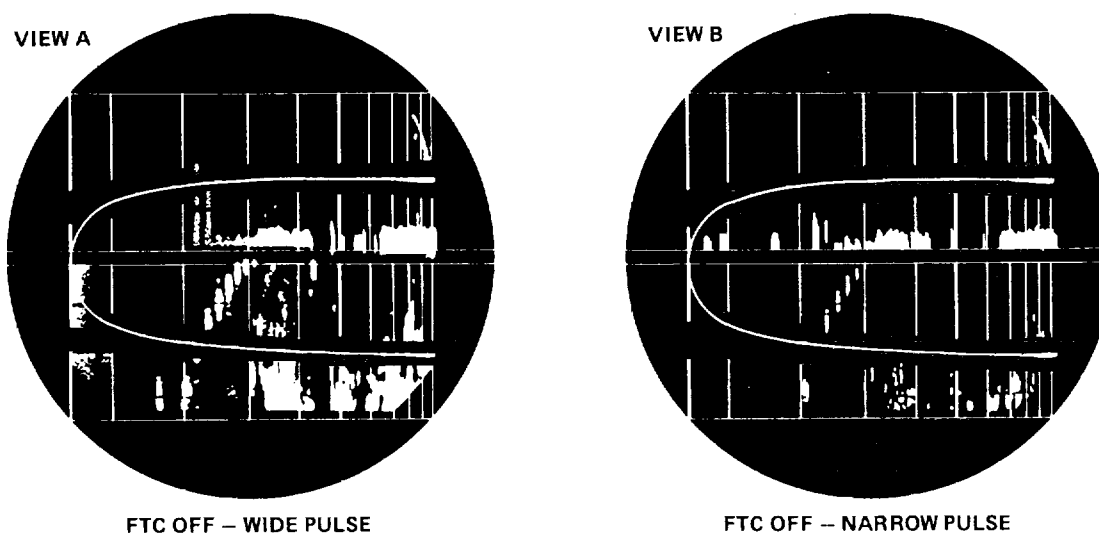
Examples of Video Clutter

305NE053

1. View A exhibits a typical display of video clutter that may exist on crt display when FTC switch is in OFF position, and TRANSMITTER switch is in WIDE PLS position. Clutter may cause difficulty in reading target return on crt display.
2. View B exhibits clutter being reduced after placing TRANSMITTER switch to NAR PLS position and FTC switch remaining in OFF position.

2-7. PRECISION APPROACH OPERATION. (CONT)

VIDEO CLUTTER (CONT)

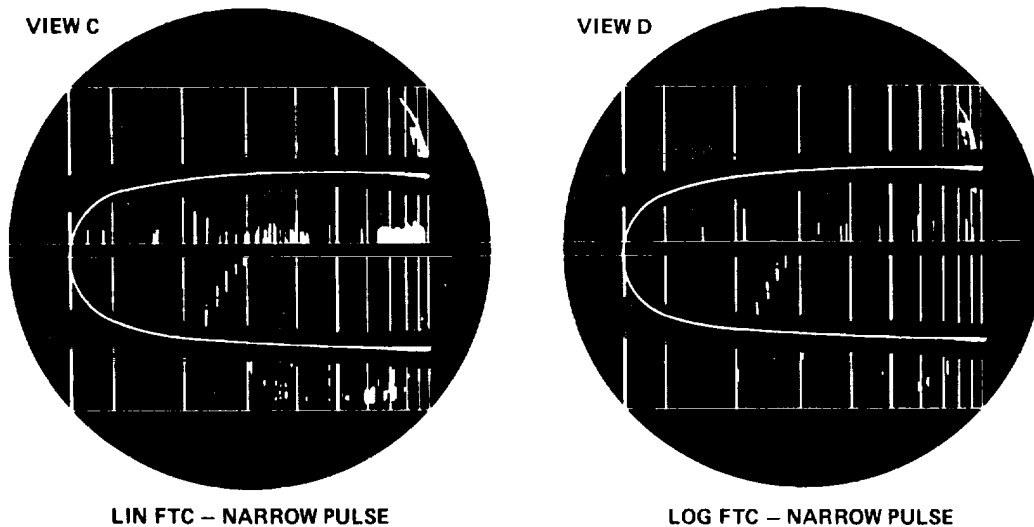

3. View C exhibits clutter being further reduced by placing FTC switch to LIN position and TRANSMITTER switch remaining in NAR PLS position. LIN FTC is used to reduce clutter from ground returns.
4. View D exhibits a still further reduction of clutter by placing FTC switch to LOG position and TRANSMITTER switch remaining in NAR PLS position. LOG FTC is used to reduce clutter from precipitation.

2-8. HEIGHT FINDER OPERATION.

The height finder operation is accomplished with the master control-indicator. The SCAN MODE switch must be in NORM, 350 EL, 600 AZ, or SIMULT position. When a slave control-indicator is used in conjunction with a master control-indicator, the slave can be operated as a monitor for precision approach operation, provided the SCAN MODE switch on the master is in NORM, 350 EL, or 600 AZ position. The slave will have a beta scan. When the SCAN MODE switch on the master is in SIMULT position, the slave will have a ppi scan. The height finding feature provides a means of determining the altitude of an aircraft (off the approach end of the runway) within the limits of - 1 to 35 degrees in elevation and 30 degrees in azimuth.

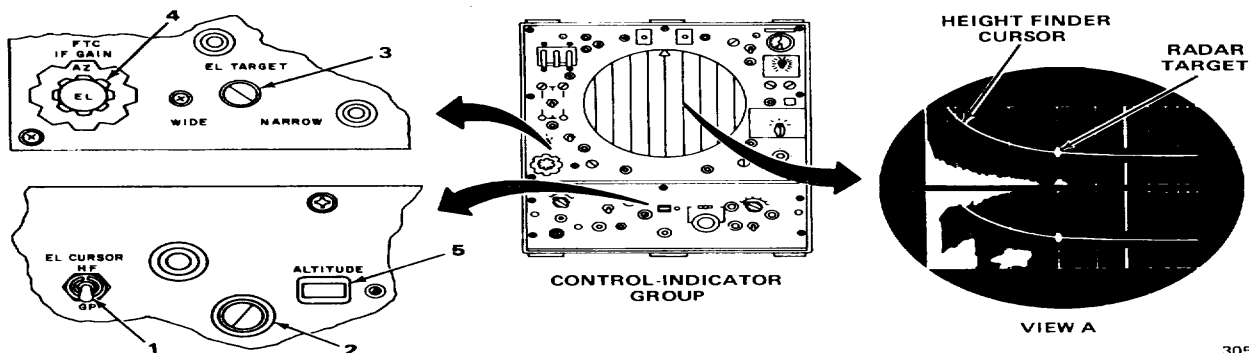

305NE055

24. HEIGHT FINDER OPERATION. (CONT)**NOTE**

Video clutter and the ways to reduce it are explained in Precision Approach Operation, Video Clutter (para 2-7) and Search Operation, Reducing Video Clutter (para 2-6).

When not in operation, perform Preliminary Control Settings (para 2-4) and Preliminary Operating Procedure (para 2-5), omitting Scan and Video Presentation checks, to place the radar set in operation. Perform Precision Approach Operation (para 2-7) first, then perform the following.

1. Place EL CURSOR switch (1) to HF position.
2. Rotate ALTITUDE control (2) clockwise or counterclockwise until the height finder cursor bisects the radar target as shown in view A.
3. Rotate EL TARGET control (3) clockwise or IF GAIN EL control (4) counterclockwise to reduce the vertical size of the radar target. Use care when operating with a slave control-indicator, so as not to reduce the radar target too much.
4. On ALTITUDE indicator (5), obtain altitude (in hundreds of feet).
5. Place EL CURSOR switch (1) to GP position.

2-9. SIMULTANEOUS MODE OPERATION.

The simultaneous mode of operation utilizes both control-indicators. The control-indicator that is cable connected to the radar set group is the master control-indicator. When the radar set is used in conjunction with a landing control system shelter, either control-indicator can be designated the master by activating the MASTER IND 1-2 switch on control-indicator C-7012rTPX-44. The master control-indicator will have a beta scan for precision approach operation and the slave control-indicator will have a ppi scan for search operation.

NOTE

Reducing video clutter is accomplished by using the controls on the master control-indicator. See Search Operation (para 2-6) and Precision Approach Operation (para 2-7) for examples of video clutter that exist on ppi and beta crt displays.

Go to Search Operation, Reducing Video Clutter (para 2-6) for procedures used to reduce clutter due to ground returns and precipitation. Be careful that the target being tracked on the slave is not lost when using controls on master control-indicator to reduce clutter.

When not in operation, perform Preliminary Control Settings (para 2-4) and Preliminary Operating Procedure (para 2-5), omitting scan and video presentation checks, to place the radar set in operation.

2.9. SIMULTANEOUS MODE OPERATION. (CONT)

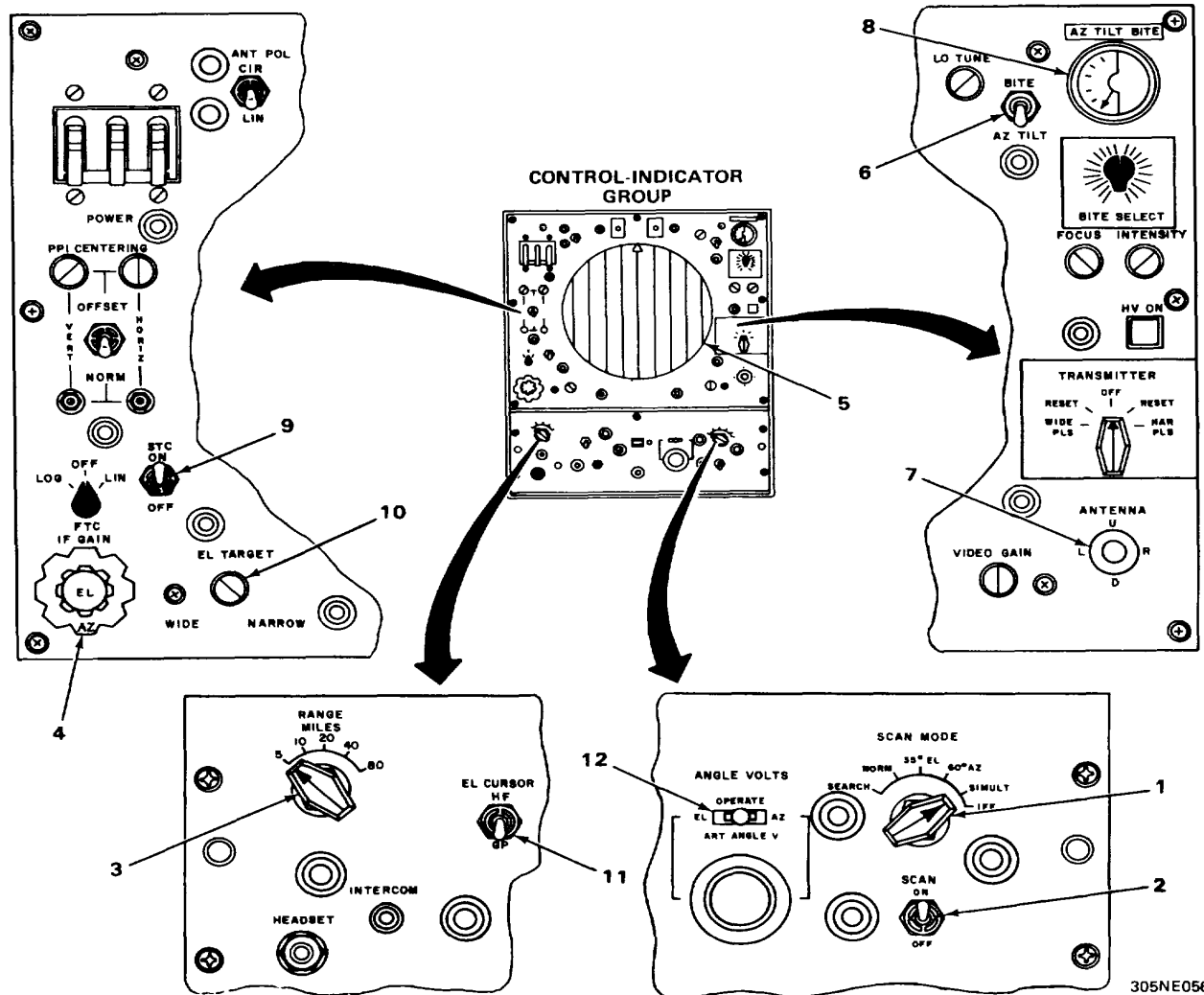

305NE056

1. Place SCAN MODE switch (1) on master to SIMULT position.
2. Place SCAN MODE switch (1) on slave to any position except IFF.
3. Place SCAN switch (2) on master to ON position.
4. Place RANGE MILES switch (3) on both control-indicators to any desired position.
5. Adjust IF GAIN AZ control (4) on master until receiver noise (grass) is visible in background of crt display (5) on both control-indicators.
6. Place BITE-AZ TILT switch (6) on both control-indicators to AZ TILT position.
7. Place ANTENNA switch (7) on master in either U or D position to adjust angle of azimuth antenna for search operation.
8. On AZ TILT/BITE meter (8) on slave, monitor tilt angle of azimuth antenna.
9. Place ANTENNA switch (7) on master in either L or R position to adjust angle of elevation antenna for precision approach operation.
10. When necessary, place STC switch (9) on master to ON position, to reduce amplitude of target return signals at close range.

2-9. SIMULTANEOUS MODE OPERATION. (CONT)

NOTE

Use offset centering feature on the slave control-indicator to extend the range when greater radar video resolution is desired at or near maximum range of display. To offset center of crt display, see Search Operation, Offsetting Video Display (para 2-6).

11. Rotate EL TARGET control (10) on master fully counterclockwise to WIDE position.
12. Place EL CURSOR switch (11) on master to GP position.
13. Place ANGLE VOLTS switch (12) on master to OPERATE position.

2-10. IFF OPERATION.

When the radar set is used in conjunction with Interrogator Set ANITPX-44, it is capable of displaying IFF video when SCAN MODE switch on master control-indicator is placed to SEARCH, SIMULT, or IFF position, and IFF ANT SCAN CONT switch on interrogator set is placed to the RADAR position. Refer to TM 11-5895468-12 for operating information on the interrogator set.

SEARCH MODE

NOTE

In the search mode of operation, radar target and IFF reply is displayed on all ranges except 80. When in the 80-mile range position, only IFF return will be seen. Refer to Scan and Video Presentation Checks and Preliminary Operating Procedure (para 2-5) for the different combination of switch settings and displayed data when operating in search mode.

When necessary, use offset centering feature on control-indicators to extend the range when greater video resolution is desired at or near maximum range of display. To offset center of crt display, see Search Operation, Offsetting Video Display (para 2-6).

When not in operation, perform Preliminary Control Settings (para 2-4) and Preliminary Operating Procedure (para 2-5), omitting scan and video presentation checks, to place the radar set in operation.

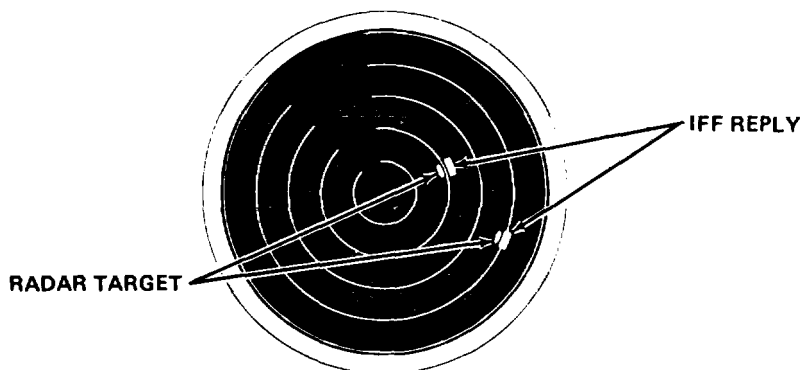

305NE059

The illustration above exhibits a typical ppi display during search operation when using IFF equipment. The radar target return appears on the display with its associated IFF return behind it.

2-10. IFF OPERATION. (CONT)

PRECISION MODE

Precision approach (precision mode) of operation utilizes beta-type scans, when the SCAN MODE switch on the master control-indicator is placed in NORM, 350 EL, or 600 AZ position. Beta scans do not display IFF information. When operating with a slave control-indicator, by placing the SCAN MODE switch on the slave to IFF position, the slave will display the IFF reply (no radar target) on a ppi scan. See Precision Approach Operation (para 2-7), and Scan and Video Presentation Checks in Preliminary Operating Procedure (para 2-5), for the different combination of switch settings and displayed data when operating in precision mode.

SIMULTANEOUS MODE

In the simultaneous mode of operation, the master control-indicator will have a beta scan and the slave a ppi scan. The slave will display the radar target and IFF reply at all ranges except 80. When the RANGE MILES switch on the slave is placed in 80 position, it will display only the IFF reply. When the SCAN MODE switch on the slave is placed in IFF position, it will display only the IFF reply at all ranges. See Simultaneous Mode Operation (para 2-9) for the procedure to operate in simultaneous mode.

IFF MODE

In the IFF mode of operation, the control-indicators are isolated from the common radar-IFF antenna control system and controlled directly by the IFF equipment. The SCAN MODE switch on either control-indicator can be placed in IFF position without affecting the other. Except for precision approaches, the slave cannot display beta scans when the SCAN MODE switch on the master is in IFF position. IFF information can be received by operating in simultaneous mode. Only the IFF reply is displayed at all ranges when the SCAN MODE switch on either control-indicator is in IFF position. See Scan and Video Presentation checks in Preliminary Operating Procedure (para 2-5) for the different combination of switch settings and displayed data when operating in IFF mode.

VIDEO CLUTTER

See Search Operation (para 2-6) and Precision Approach Operation (para 2-7) for examples of video clutter that may be encountered during IFF operation. To reduce video clutter, see Search Operation, Reducing Video Clutter (para 2-6).

2-11. STANDBY CONDITION.

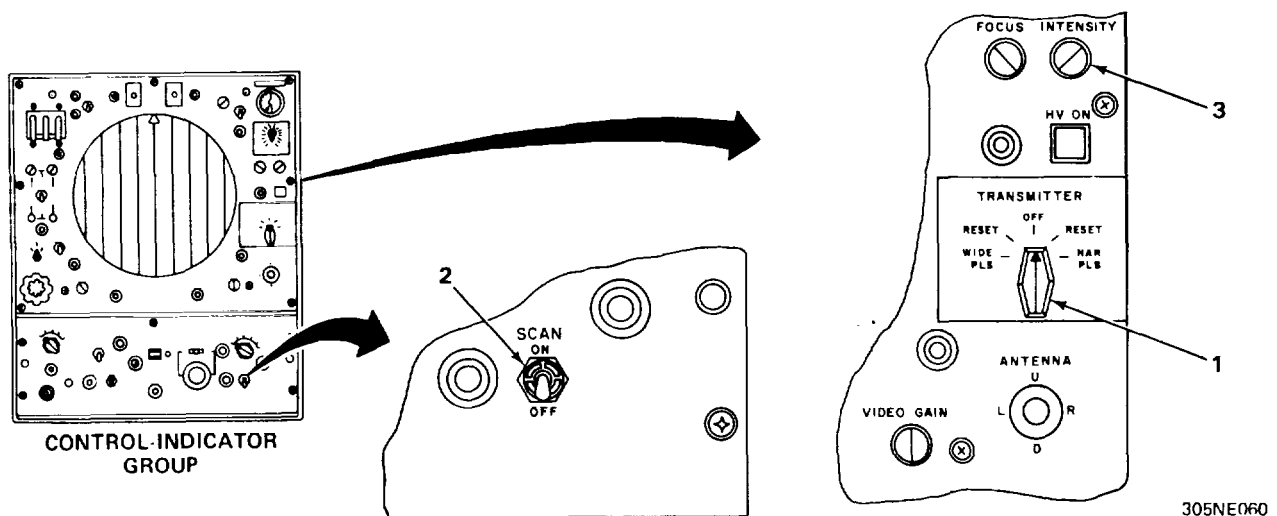

2-11. STANDBY CONDITION. (CONT)

To place the radar set in standby, perform the following on master and slave control indicators:

1. Place TRANSMITTER switch (1) on master to OFF position.
2. Place SCAN switch (2) on master to OFF position.
3. Rotate INTENSITY controls (3) on both control-indicators to fully counterclockwise position.

2-12. NORMAL SHUTDOWN.

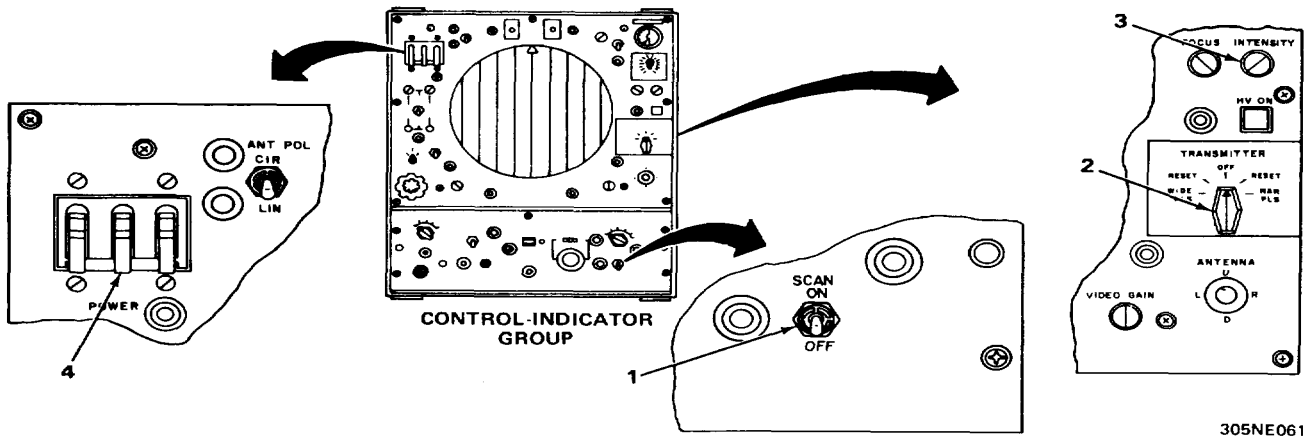

To completely turn off the radar set, perform the following on master and slave control indicators:

1. Place SCAN switch (1) on master to OFF position.
2. Place TRANSMITTER switch (2) on master to OFF position.
3. Rotate INTENSITY controls (3) on both control-indicators to full CCW position.
4. Place POWER circuit breakers (4) on both control-indicators to OFF position.

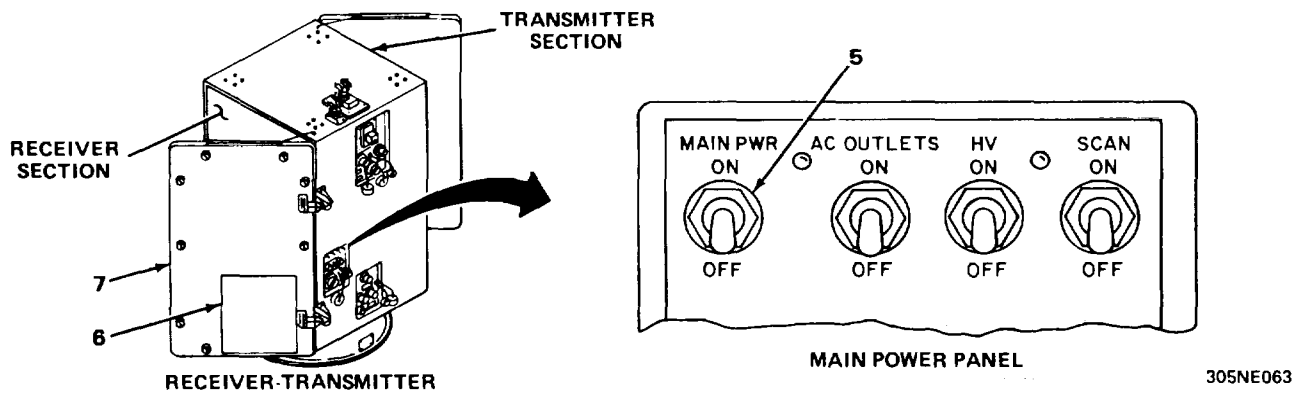

5. Place MAIN PWR circuit breaker (5) to OFF position.
6. Close air vent (6) on receiver door (7).

2-13. EMERGENCY SHUTDOWN.

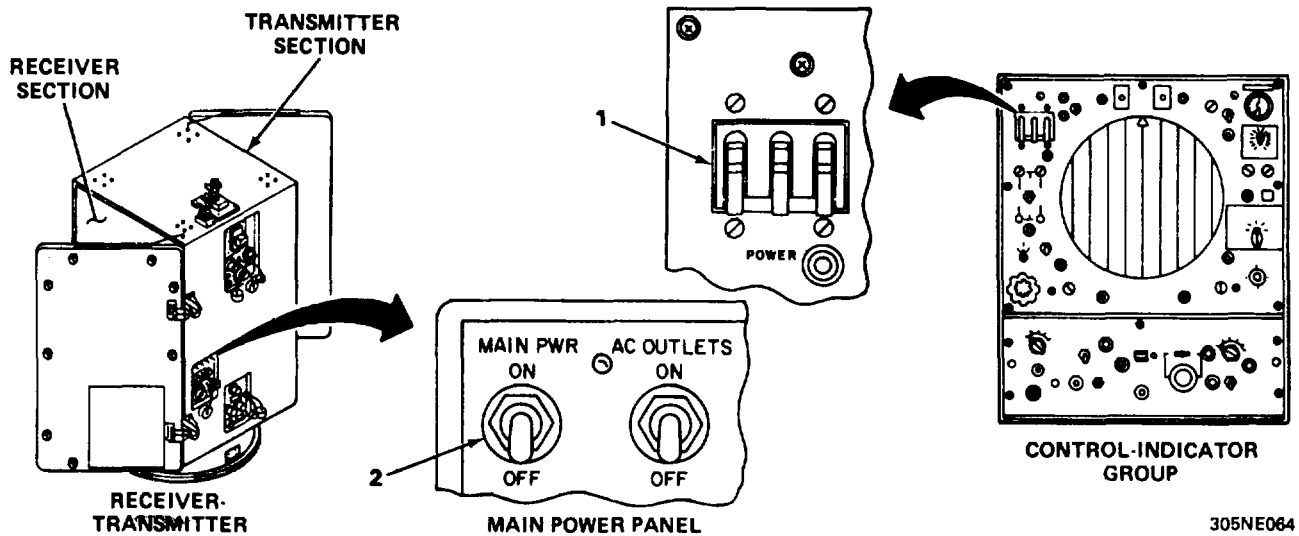

In the event of an emergency, where there is insufficient time to accomplish a normal shutdown, perform the following operations.

1. Place POWER circuit breakers (1) on both control-indicators to OFF position.
2. Place MAIN PWR circuit breaker (2) on receiver-transmitter to OFF position.

NOTE

Before reapplying power to the radar set, steps 1, 2, and 3 of Normal Shutdown (para 2-12) must be performed.

Section IV OPERATION UNDER UNUSUAL CONDITIONS

| Subject | Para | Page |
|---------------------------------|------|------|
| General..... | 2-14 | 2-34 |
| Emergency Procedures..... | 2-15 | 2-36 |
| Jamming and ECM Procedures..... | 2-16 | 2-37 |

2-14. GENERAL.

Extreme climatic conditions can be encountered when operating the radar set in some geographical regions. The service life of the equipment can be extended by increasing the frequency of specific inspections and maintenance services. See Lubrication Procedures (para 4-48). Video clutter can be reduced by following the procedures In Search Operation, Reducing Video Clutter (para 2-6).

TROPICAL CONDITIONS

1. Inspect dehydrator cartridges in waveguide adapters daily. See Dehydrator Cartridge Inspection (para 3-5) for Instructions.
2. Inspect for damaged surfaces and surfaces of chipped or peeling paint daily.
3. Wait 10 minutes before activating TRANSMITTER and HV ON switches when radar set has been turned off for a long period of time.

2-14. GENERAL. (CONT)

4. Rather than turning off equipment, remain in standby condition (para 2-11) when possible.

NOTE

Whenever the TRANSMITTER switch is placed in WIDE PLS or NAR PLS position, HV ON switch must be activated to place transmitter in operation.

5. Operate with TRANSMITTER switch in NAR PLS position during hottest part of day, when possible.
6. To reduce video clutter due to precipitation, see Search Operation, Reducing Video Clutter, Precipitation (para 2-6).

SALT AIR AND SEA SPRAY

1. Inspect dehydrator cartridges in waveguide adapters daily. See Dehydrator Cartridge Inspection
2. Check for corrosion and tightness of waveguides and cable connectors daily.
3. To reduce video clutter due to ground returns, see Search Operation, Reducing Video Clutter, Ground Returns (para 2-6).
4. Flush exposed surfaces with fresh water, whenever possible.

DESERT

1. Check air filters at bottom of receiver-transmitter, receiver door, and pulse generators daily and after each sand or dust storm and have cleaned when dirty.
2. If possible, do not operate during sand or dust storms. Keep radar in normal shutdown condition (para 2-12).
3. Remain in standby condition (para 2-11) when possible during operation.

NOTE

Whenever the TRANSMITTER switch is placed in WIDE PLS or NAR PLS position, HV ON switch must be activated to place transmitter in operation.

4. Operate with TRANSMITTER switch in NAR PLS position during hottest part of day, when possible.
5. To reduce video clutter when operating during a sandstorm, see Search Operation, Reducing possible. Video Clutter, Ground Returns (para 2-6).
6. Keep ground surfaces wet with water at grounding rods.

ARCTIC REGIONS

1. Remain in standby condition (para 2-11) when possible, rather than turning off equipment.

NOTE

Whenever the TRANSMITTER switch is placed in WIDE PLS or NAR PLS position, HV ON switch must be activated to place transmitter in operation.

2. Wait 15 minutes before activating TRANSMITTER and HV ON switches, when radar set has been turned off for a long period of time.

2.14. GENERAL. (CONT)

ARCTIC REGIONS (CONT)

CAUTION

Do not let ice exceed 0.8 inch (2 cm) thick on the azimuth and elevation antenna drives and the azimuth and two elevation antenna rotary joints. To avoid damage to equipment, do not chip ice with hammer or sharp instruments.

- Using electric heater, soldering iron, or torch, remove ice.

EXTREME WET AND COLD

- Inspect dehydrator cartridges in waveguide adapters daily. See Dehydrator Cartridge Inspection
- Inspect for damaged surfaces and surfaces of chipped or peeling paint daily.
- Check for corrosion and tightness of waveguides and cable connectors daily.
- Wait 15 minutes before activating TRANSMITTER and HV ON switches when radar set has been turned off for a long period of time.
- Remain in standby condition (para 2-11) when possible, rather than turning off equipment.

NOTE

Whenever the TRANSMITTER switch is placed in WIDE PLSE or NAR PLSE position, HV ON switch must be activated to place transmitter in operation.

- To reduce video clutter due to precipitation, see Search Operation, Reducing Video Clutter, Precipitation (para 2-6).

2-15. EMERGENCY PROCEDURES.

When an equipment malfunction occurs, the radar set should be turned off immediately (para 2-13) and organizational maintenance personnel notified. Limited operations in an emergency can be maintained under some conditions of partial equipment failure, after it is determined that such operation is advisable.

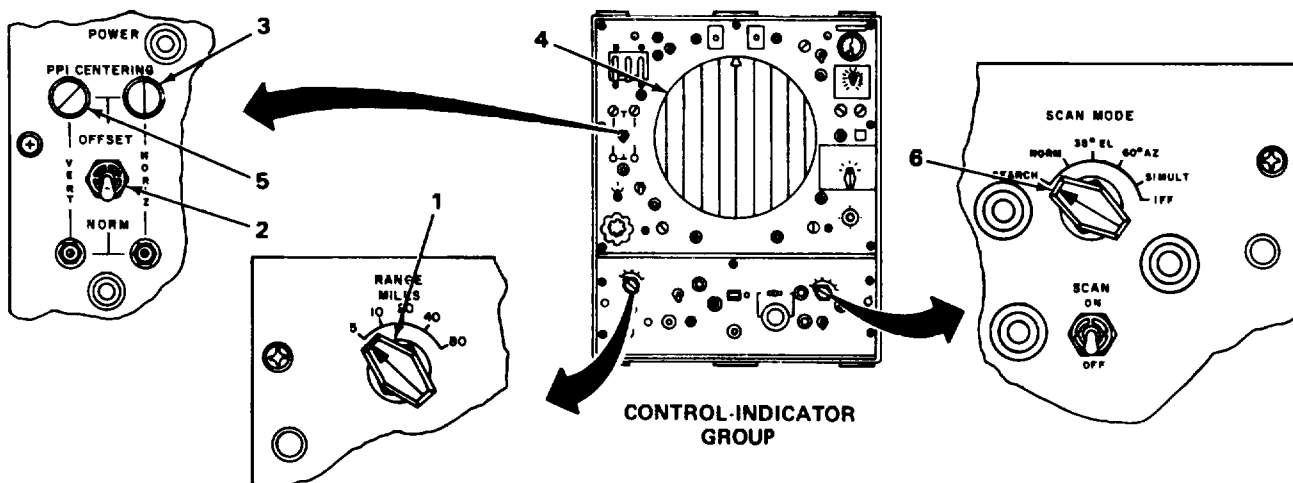

305NE065

2-15. EMERGENCY PROCEDURES. (CONT)**RANGE FAILS**

When in search operation and any one range fails, the next shorter range may be off-centered by performing the following operations.

1. Place RANGE MILES switch (1) to next lower range.
2. Place PPI CENTERING NORM-OFFSET switch (2) to OFFSET position.
3. Adjust PPI CENTERING HORIZ control (3) to position display (4) horizontally.
4. Adjust PPI CENTERING VERT control (5) to position display (4) vertically.
5. Place PPI CENTERING NORM-OFFSET switch (2) to NORM position after display (4) is offset.

10-DEGREE ELEVATION FAILS

When In precision approach operation, with SCAN MODE switch (6) in NORM position and 10-degree elevation display fails, place SCAN MODE switch (6) to 350 EL position.

NOTE

The accuracy and resolution will be reduced. If both 10- and 35-degree elevation displays fail, use azimuth display for azimuth corrections, if possible.

ALL PRECISION MODES FAIL

When in precision mode operation, with SCAN MODE switch (6) in NORM, 350 EL, 600 AZ, or SIMULT position and all functions fail, operate the radar in search mode by placing SCAN MODE switch (6) to SEARCH position.

NOTE

When in the search mode of operation, directional information may be used to make airport surveillance radar (asr) approaches. No elevation data is used. This operation is not as accurate as the precision approach operation. The accuracy can be improved by using as short a range as possible and offset centering described in RANGE FAILS.

When any of the controls on the master control-indicator that control the radar set group fail, such as the SCAN OR TRANSMITTER switches, operation can be continued by interchanging the slave control-indicator with the master. When operating in a landing control central system, an indicator (master) selector 1 or 2 switch is provided. (Refer to TM 11-5895-474-12 addendum.)

2-16. JAMMING AND ECM PROCEDURES.

The radar receiver can receive signals, other than the return signal (echo) of the transmitter, provided they are in the correct frequency range. Unwanted signals produce wrong information on the radar display, or they may clutter the display with so much interference that the targets cannot be distinguished. Deliberate generation of such unwanted signals is called electronic countermeasures (ecm) or jamming. There are two types of jamming: transmission and reflected.

2-16. JAMMING AND ECM PROCEDURES. (CONT)

TRANSMISSION JAMMING

Transmission jamming is caused by interfering signals generated by a jamming transmitter. The jamming transmitter may be fixed ground-based, airborne, free-falling (expendable transmitters dropped from aircraft), or transported by other means. Jamming signals may be continuous wave, amplitude modulated, frequency modulated, pulsed transmission, or a combination thereof.

A continuous wave (cw) jamming signal is a pure rf carrier at one fixed frequency with no modulation or intelligence. When a high-power cw jammer is operating at close ranges, the radar display can be devoid of all radar returns, or have severe clutter when the jamming signal produces beat frequencies. At greater ranges, cw jamming tends to reduce the sensitivity of the radar receiver, as if the IF GAIN controls were rotated counterclockwise. Clutter usually occurs in wedge-shaped areas in the direction of the cw jamming source.

Amplitude-modulated (am) jamming signal may be amplitude modulated by one or a combination of various methods such as with sine waves, square waves, sawtooth wave, or mechanical means, the most common type used in noise modulation. The result of am jamming on the crt display is similar to cw jamming. The clutter is similar to that produced by intense rain or snow.

Frequency-modulated (fm) jamming will cause unwarranted signals to appear irregularly on the crt display as the modulating frequency varies about the operating frequency of the radar set. Fm jamming usually causes random strobing on the crt display (intermittent intensified sweeps). At close ranges, the strobing can become intense enough to completely saturate the crt display. At longer ranges, the strobing occurs mostly in the direction of the jammer and occasionally occurs 180 degrees away from the jammer (reception on the backside of the antenna).

In pulsed jamming, the signal is turned on abruptly for short periods of time. The jammers can operate in a synchronous or nonsynchronous mode at varied pulse widths and repetition rates. When in the synchronous mode, the jamming signal is exactly the same as the pulse repetition rate of the radar set, or an exact multiple or submultiple of it. This could cause intense range rings, similar to range marks, varying in width (range) to appear on the crt display. These rings could vary from a fine line to a width sufficient to block the complete radar display, depending on the power and range of the jammer. Nonsynchronized jammers can cause an unlimited number of patterns, ranging from a light sprinkling of interference, to a spiraling pinwheel design (or running rabbits), or saturation of the crt display, depending upon the pulse width and repetition rate of the jammer.

REFLECTED JAMMING

Reflected jamming is caused by use of reflecting materials that reflect the radar signal just as the target does. One common technique is "window" jamming. Window is the name given to thin strips of aluminum or other metal, cut to a length that results in maximum signal reflection at the frequency of the radar being jammed. The strips may be dispersed by aircraft at high altitude or missiles and projectiles with timed dispersions. As the strips flutter to earth, they appear as intense clutter or saturated video over large areas of the crt display, similar to heavy rain or snow clutter.

NOTE

Refer to TM 11-750, Electronic Countermeasures for the Operator, for a detailed discussion of jamming, deception signals, and tactics employed against radar systems.

2-16. JAMMING AND ECM PROCEDURES. (CONT)

COUNTERMEASURES, REPORTING AND RECORDING

Immediate reporting of countermeasures and accurate, complete recording of countermeasures reception for additional reports are important responsibilities of the radar operator. The initial report alerts command that countermeasures are being used; and countermeasures usually indicate an impending enemy action. Detailed records, included in subsequent reports, inform higher authorities of the countermeasure capabilities of the enemy. Follow the procedures given in local SOP for reporting and recording countermeasures.

ANTI-JAMMING PROCEDURES

The following methods and techniques are applicable for all scan modes of operation. They are arranged in the following order in consideration of their ease of performance and probable effectiveness.

Reflected Jamming

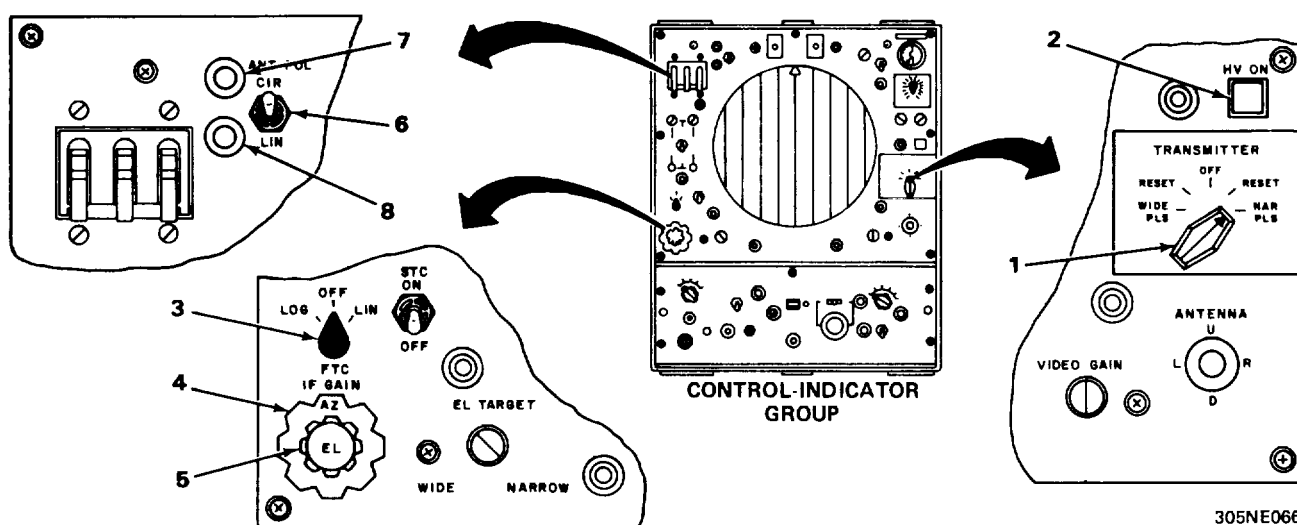

305NE066

1. Place TRANSMITTER switch (1) to NAR PLS position.
2. Press HV ON switch (2). Indicator light in switch will light.
3. Place FTC switch (3) in LIN or LOG position.
4. Being careful not to lose target, rotate IF GAIN AZ (4) and IF GAIN EL (5) controls
5. Place ANT POL switch (6) to CIR position. CIR indicator (7) will light, LIN indicator (8) will extinguish, and maximum detection range will be reduced approximately 20 percent.

2-16. JAMMING AND ECM PROCEDURES. (CONT)

Transmission Jamming

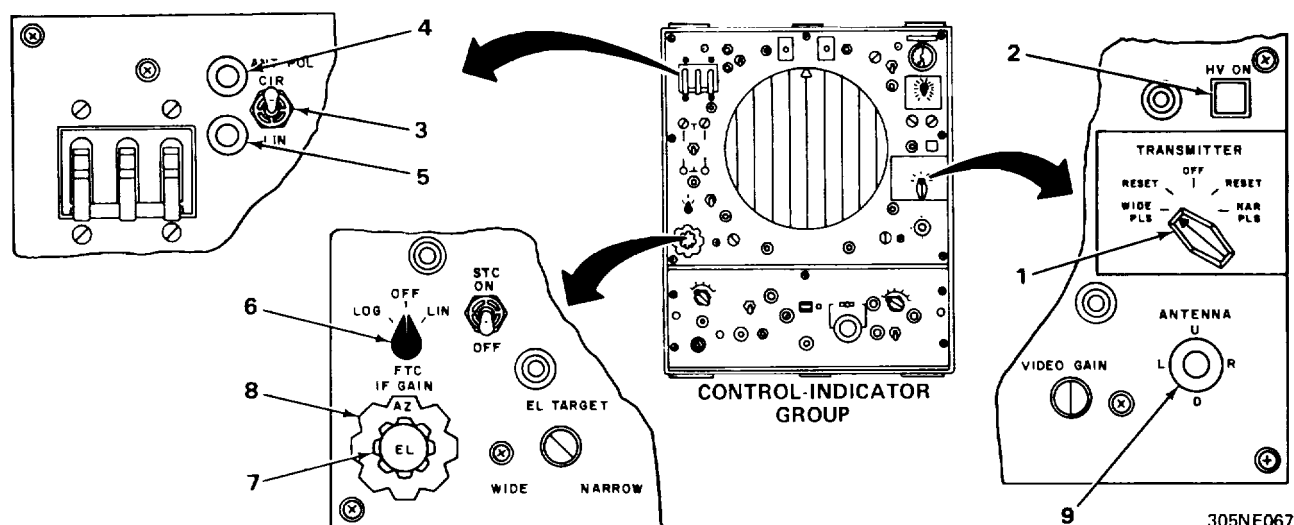

NOTE

This operation will minimize effects of jamming that has both vertical and horizontal polarization characteristics.

6. Place TRANSMITTER switch (1) to WIDE PLS position.
7. Press HV ON switch (2). Indicator light in switch will light.
8. Place ANT POL switch (3) to CIR position. CIR indicator (4) will light, LIN indicator (5) will extinguish, and maximum detection range will be reduced approximately 20 percent.
9. Place FTC switch (6) in LIN or LOG position.
10. Rotate IF GAIN EL (7) and IF GAIN AZ (8) controls counterclockwise, taking care not to lose target.
11. Move ANTENNA switch (9) to U and D position when in search operation.

IFF Returns

In an emergency, when in search operation and operating with Interrogator Set ANITPX-44, rotate the IF GAIN AZ and EL controls to fully counterclockwise position to prevent all radar video from being displayed. Use IFF return signals for range and bearing information. This may be used for both reflected and transmission jamming. Refer to TM 11-5895-468-12 for operating instructions for Interrogator Set ANITPX-44.

CHAPTER 3

OPERATOR MAINTENANCE

| Subject | Section | Page |
|---|---------|------|
| Operator Troubleshooting Procedures | I | 3-1 |
| Operator Maintenance Procedures | II | 3-1 |

Section I OPERATOR TROUBLESHOOTING PROCEDURES

This section contains general troubleshooting Information for the operator of the radar set. If a problem is observed, proceed with the following corrective actions:

- Check that all controls, switches, and circuit breakers are In the correct position for the mode of operation you are in.
- Check that all cables and connectors are connected properly.
- Check that primary power source Is supplying power to the radar set.

The corrective actions above may not solve all the problems you may observe. If corrective actions do not solve your problem, report problem to a higher level of maintenance.

Section II OPERATOR MAINTENANCE PROCEDURES

| Subject | Para | Page |
|--|------|------|
| General | 3-2 | 3-2 |
| Cleaning and Inspection | 3-3 | 3-2 |
| Cursor Alinement Checks | 3-4 | 3-4 |
| Dehydrator Cartridge Inspection | 3-5 | 3-10 |
| Operational Check | 3-6 | 3-11 |
| Front Panel and Indicator Lamp Replacement | 3-7 | 3-20 |
| Fuse Replacement | 3-8 | 3-21 |

3-2. GENERAL.

This section provides instructions for operator maintenance of the ANITPN-18A radar set. The following Initial setup information applies to all procedures.

Resources required are not listed unless they apply to the procedure.

One person can do all operator maintenance procedures.

The normal standard equipment condition to start a maintenance task is power off. Equipment Condition is not listed unless some other condition is required.

3-3. CLEANING AND INSPECTION.

CLEANING

Cleaning operations should be performed once each day if the radar set is used daily. If not in operation daily, it should be cleaned before and after operation. When it is maintained in standby condition, it should be cleaned once each week.

WARNING

Fumes of TRICHLOROTRIFLUOROETHANE are poisonous. Provide adequate ventilation whenever you use TRICHLOROTRIFLUOROETHANE. Do not use solvent near heat or open flame. TRICHLOROTRIFLUOROETHANE will not burn, but heat changes the gas into poisonous, irritating fumes. DO NOT breathe the fumes or vapors. TRICHLOROTRIFLUOROETHANE dissolves natural skin oils. DO NOT get the solvent on your skin. Use gloves, sleeves, and an apron that the solvent cannot penetrate. If the solvent is taken internally, consult a physician immediately.

1. Using a lint-free cloth, clean exterior surfaces of equipment and mechanical assemblies. Dampen cloth (not wet) with trichlorotrifluoroethane to remove ground-in dirt, grease, and fungus. Report any corrosion to organizational maintenance.
2. With a clean lint-free cloth and soft-bristled brush, clean plugs, jacks, and front panel controls and indicators. Meter faces and front panels may be cleaned using a weak solution of water and mild soap. Avoid excessive amount of solution on cloth and do not let solution enter behind controls or panel mounting hardware of controls and indicators.

3-3. CLEANING AND INSPECTION. (CONT)

3. Clean exterior and pins of connectors of interconnecting cables with a brush. Cleaning compound may be used with brush and cloth to remove grease, fungus, and light tarnish. When connector contacts (pins and receptacles) exhibit corrosion, they must be replaced.
4. Keep reflective surfaces on antennas and covers on horn and polarizer assemblies clean at all times. Clean with soft, lint-free cloth. Cloth may be used with weak solution of water and mild soap. Ground-in dirt, if necessary, can be removed with a cloth dampened (not wet) with cleaning compound and used sparingly.

INSPECTION

During routine cleaning, visual inspections can be made for minor defects and discrepancies that could develop into major troubles. Also during operation, unusual noises and vibrations that could cause problems at a later time should be noted. Some typical items to be checked include the following:

1. Damaged surfaces and areas of chipped or peeling paint, corrosion, and fungus.
2. Loose, missing, or damaged mounting hardware, control knobs, switches, panel screws, headset jacks, fuse mountings, indicator lamps, chassis handles, and connectors.
3. Loose or binding hinges.
4. Structural parts sprung or twisted out of shape, or otherwise damaged.
5. Cables and connectors loose or disconnected or loose gland nuts.
6. Broken, frayed, or cracked insulation on cables.
7. Signs of oil leaks or seepage in mechanical assemblies.
8. Correct fit and seating of equipment covers and weatherproof seals.
9. Defaced, missing, or obscured identification plates.
10. Overheated components, indicated by discoloration, blistering, bulging of containers, or leak-age of insulating compounds, accompanied by peculiar odors.
11. Unusual noises and vibrations in mechanical assemblies during operation.

3-4. CURSOR ALINEMENT CHECKS.

The azimuth, elevation, and height finder cursors must be properly aligned before using them to direct aircraft. The operator should perform these checks each day before operating the equipment. If the cursors are not properly aligned, the appropriate cursor alignments (para 4-28) should be performed. Perform checks on both master and slave control-indicators.

NOTE

When not in operation, perform Preliminary Control Settings (para 2-4) and Preliminary Operating Procedures (para 2-5), omitting scan and video presentation checks, to place the radar set in operation.

AZIMUTH CURSOR

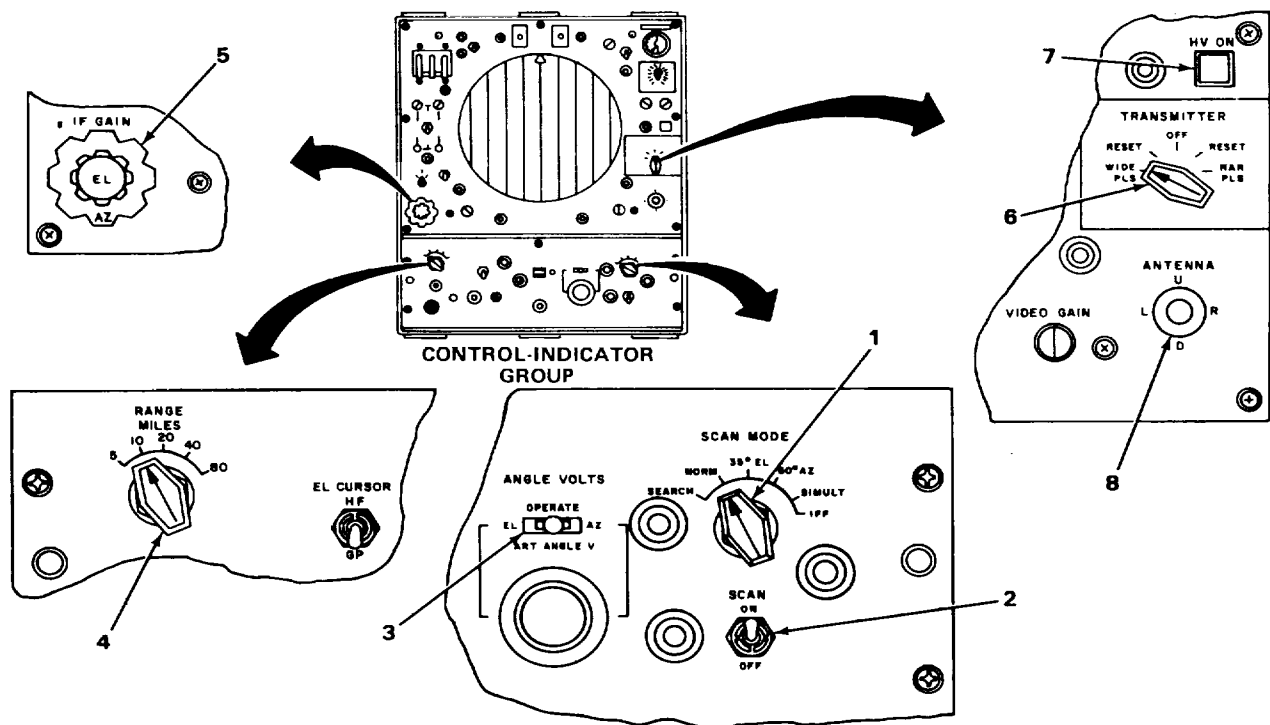

305NE068

1. Place SCAN MODE switch (1) on both control-indicators to NORM position.
2. Place SCAN switch (2) on master to ON position.
3. Place ANGLE VOLTS switch (3) on both control-indicators to OPERATE position.
4. Place RANGE MILES switch (4) on both control-indicators to 10 position.
5. Adjust IF GAIN AZ control (5) on master control-indicator to desired level.
6. Place TRANSMITTER switch (6) on master to WIDE PLS or NAR PLS position.
7. Press HV ON switch (7) on master. HV ON indicator in switch will light on both control
8. Use ANTENNA switch (8) on master to position azimuth antenna.

3-4. CURSOR ALINEMENT CHECKS. (CONT)

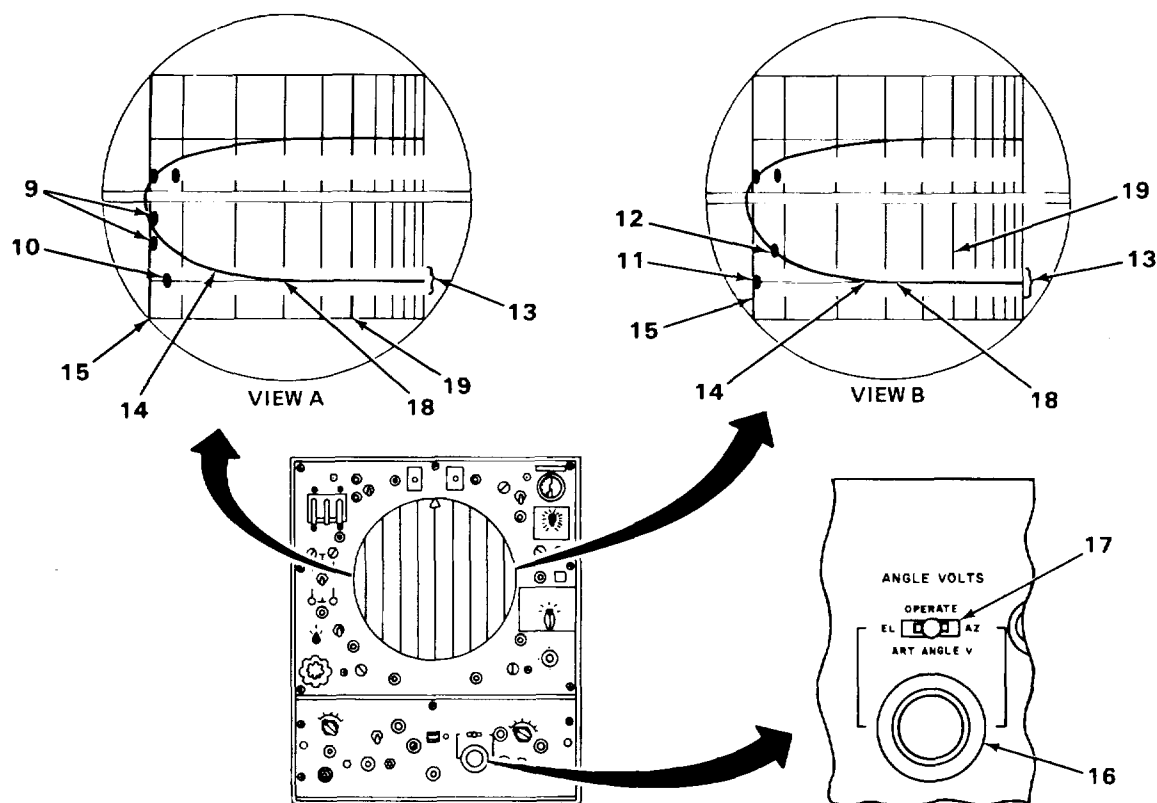

305NE069

NOTE

There are two views to represent the two configurations of target reflector placements. View A illustrates two target reflectors (9) placed on either side of runway and one target reflector (10) representing the runway parallel line. View B illustrates one target reflector (11) representing the runway parallel line and one target reflector (12) representing the centerline-of-runway. The blanked section (13) in the range marks represents servo position of elevation antenna.

For right-of-runway coverage, the azimuth cursor (14) will curve down; for left-of-runway coverage the azimuth cursor will curve up.

9. Check that touchdown range mark (15) passes through the leading edge of target reflectors, (9, view A), or (11, view B) in the azimuth display on both control-indicators.
10. Check that the closed-in or curved portion of the azimuth cursor (14) bisects the distance between the target reflectors (9, view A), or bisects the target reflector (12, view B) in the azimuth display on both control-indicators.
11. Accurately set ART ANGLE V control dial (16) on both control-indicators to the 5-mile intercept setting recorded during the initial circuit alinement (para 4-28).
12. Momentarily place ANGLE VOLTS switch (17) on both control-indicators to AZ position, then back to operate position. (The artificial sweep (18) will appear on the azimuth display when the ANGLE VOLTS switch (17) is in the AZ position.) Check that the azimuth cursor (14) inter-sects the 5-mile range mark (19) where the artificial sweep trace (18) crosses 5-mile range mark (19) (view A or B) in azimuth display on both control-indicators.

3-4. CURSOR ALINEMENT CHECKS. (CONT)

ELEVATION CURSOR

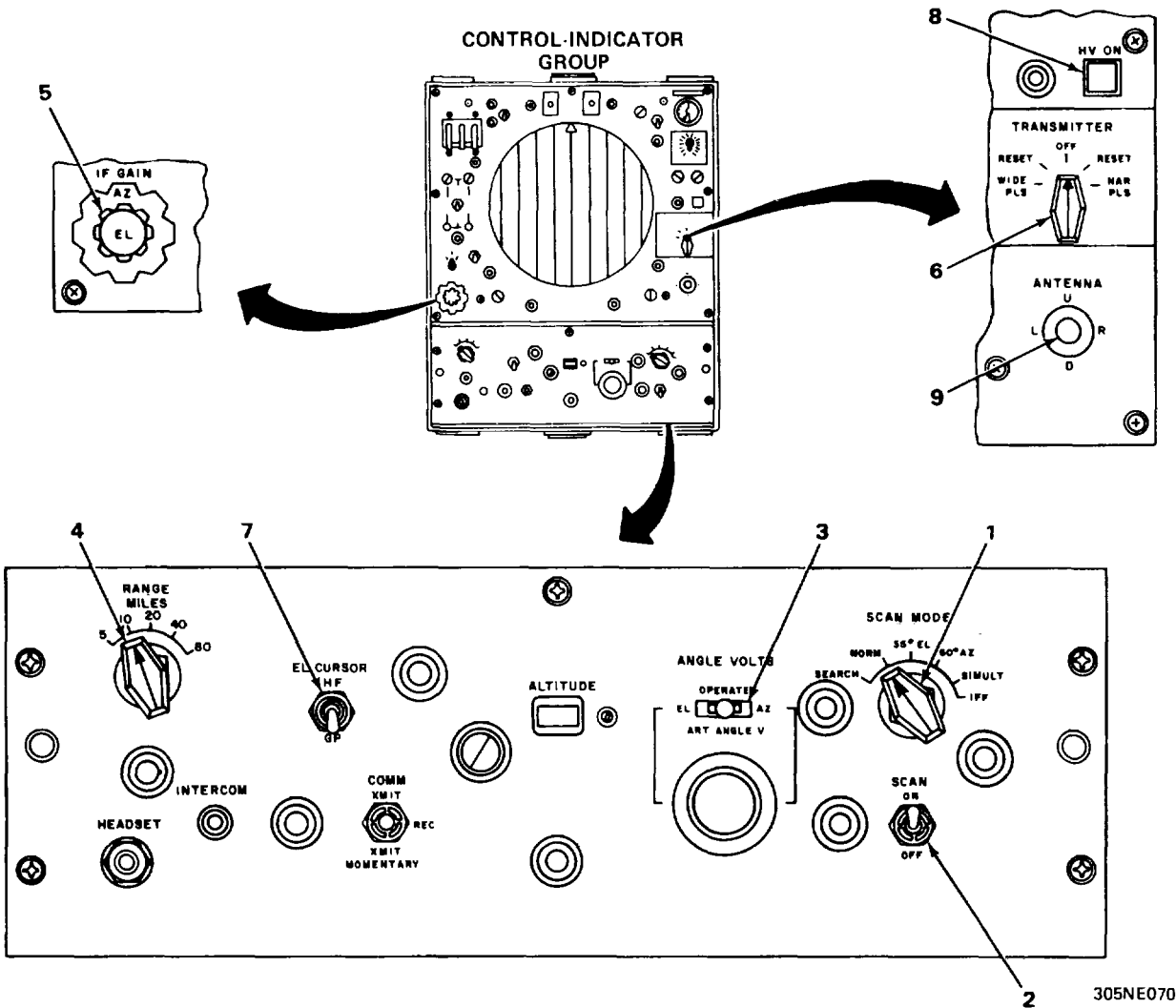

1. Place SCAN MODE switch (1) on both control-indicators to NORM position.
2. Place SCAN switch (2) on master to ON position.
3. Place ANGLE VOLTS switch (3) on both control-indicators to OPERATE position.
4. Place RANGE MILES switch (4) on both control-indicators to 10 position.
5. Adjust IF GAIN EL control (5) on master control-indicator to desired level.
6. Place TRANSMITTER switch (6) on master to WIDE PLS or NAR PLS position.
7. Place EL CURSOR switch (7) to GP position.
8. Press HV ON switch (8) on master. HV ON indicator lamp in switch will light on both control-indicators.
9. Use ANTENNA switch (9) on master to position elevation antenna.

3-4. CURSOR ALIGNMENT CHECKS. (CONT) TM115840281121

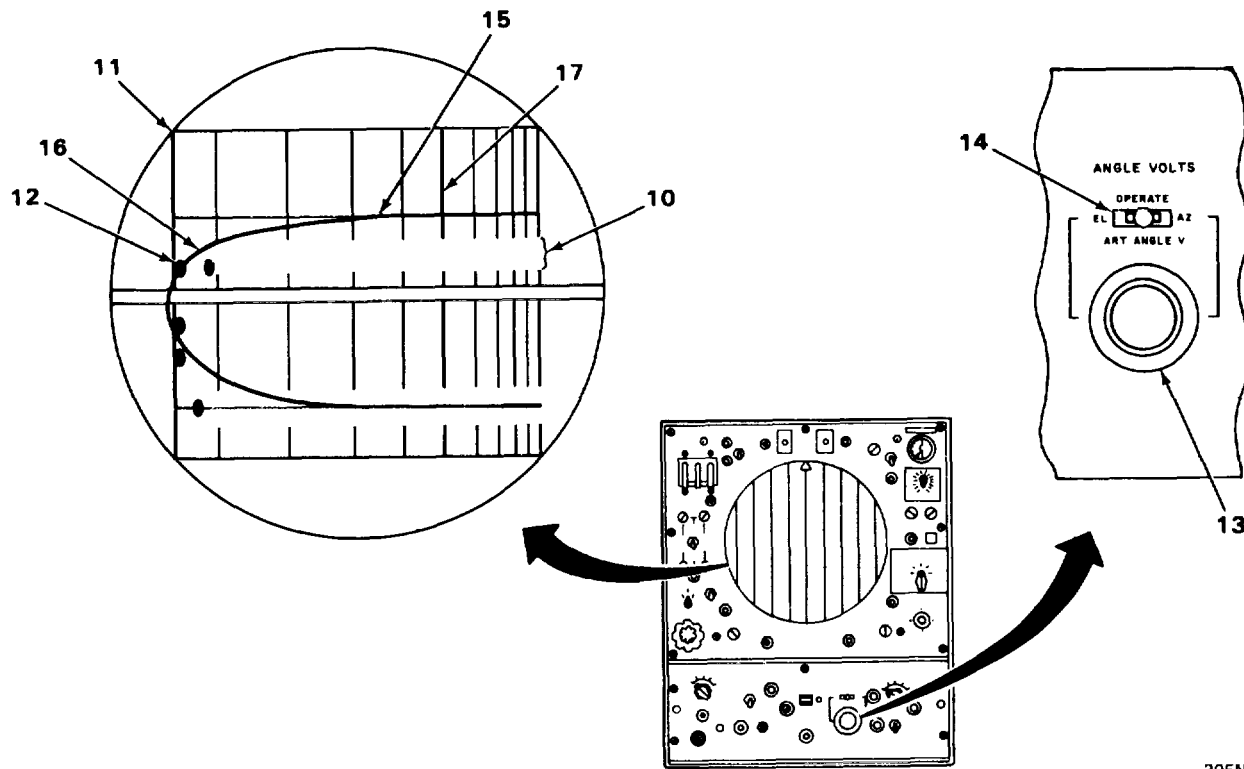

305NE225

NOTE

The blanked section (10) in the range marks represents the tilt position of the azimuth antenna.

10. Check that the touchdown range mark (11) passes through the leading edge of the target reflector (12) in the elevation displays on both control-indicators.
11. Accurately set ART ANGLE V control dial (13) on both control-indicators to the td setting recorded during initial circuit alignment (para 4-28).
12. Momentarily place ANGLE VOLTS switch (14) on both control-indicators to EL position, then back to OPERATE position. (The artificial sweep (15) will appear on the elevation display when the ANGLE VOLTS switch (14) is placed in the EL position.) Check that the elevation cursor (16) intersects the target reflector (12) where the artificial sweep trace (15) intersects the target
13. Accurately set ART ANGLE V control dial (13) on both control-indicators to the 5-mile intercept (gp setting) recorded during the initial circuit alignment.
14. Momentarily place ANGLE VOLTS switch (14) on both control-indicators to EL position and then back to OPERATE position. Check that the elevation cursor (16) intersects the 5-mile range mark (17) where the artificial sweep trace (15) crosses the 5-mile range mark (17).

3-4. CURSOR ALINEMENT CHECKS. (CONT)

HEIGHT FINDER CURSOR

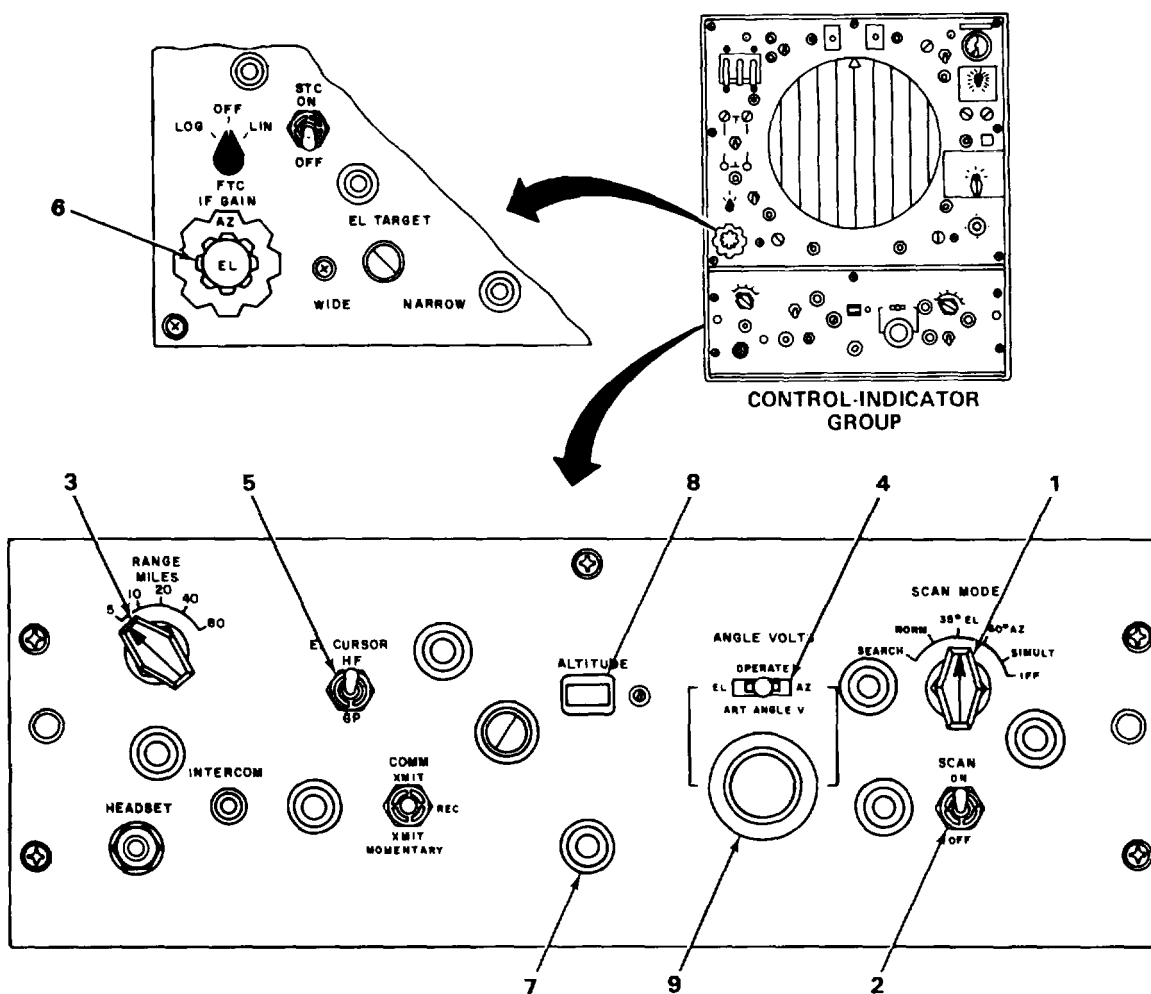

1. Place SCAN MODE switch (1) on both control-indicators to 350 EL position.
2. Place SCAN switch (2) on master to ON position.
3. Place RANGE MILES switch (3) on both control-indicators to 5 position.
4. Place ANGLE VOLTS switch (4) on both control-indicators to OPERATE position.
5. Place EL CURSOR switch (5) on both control-indicators to HF position.
6. Rotate IF GAIN EL control (6) on master control-indicator fully counterclockwise.
7. Set ALTITUDE control (7) to read field elevation plus 300 feet in counter window (8) on both control-indicators.

3-4. CURSOR ALINEMENT CHECKS. (CONT)

8. Accurately set ART ANGLE V control dial (9) on both control-indicators to 7-mile intercept setting recorded during initial circuit alinement.

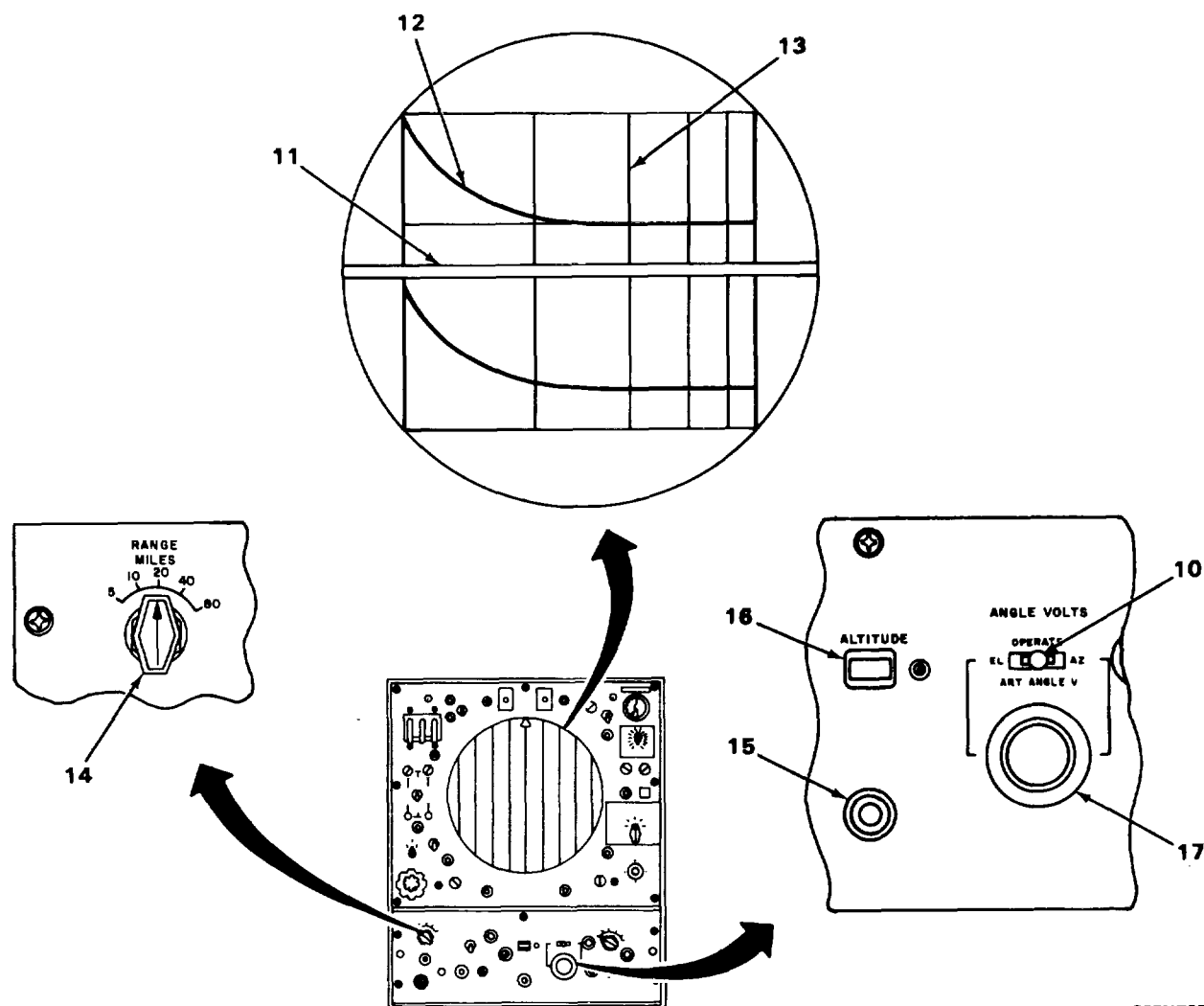

305NE226

9. Momentarily place ANGLE VOLTS switch (10) to EL position and then back to OPERATE. (The artificial sweep trace (11) will appear on the elevation display when the ANGLE VOLTS switch (10) is placed in EL position.) Check that height finder cursor (12) intersects 2-mile range mark (13) where the artificial sweep trace (11) crosses the 2-mile range mark (13).
10. Place RANGE MILES switch (14) on both control-indicators to 20 position.
11. Set ALTITUDE control (15) to indicate field elevation plus 15,000 feet in counter window (16) on both control-indicators.
12. Accurately set ART ANGLE V control dial (17) on both control-indicators to 10-mile intercept setting recorded in the circuit alinement procedures.
13. Momentarily place ANGLE VOLTS switch (10) on both control-indicators to EL position and then back to OPERATE position; check that height finder cursor (12) intersects 10-mile range mark where artificial sweep trace (11) crosses 10-mile range mark.

3-5. DEHYDRATOR CARTRIDGE INSPECTION.

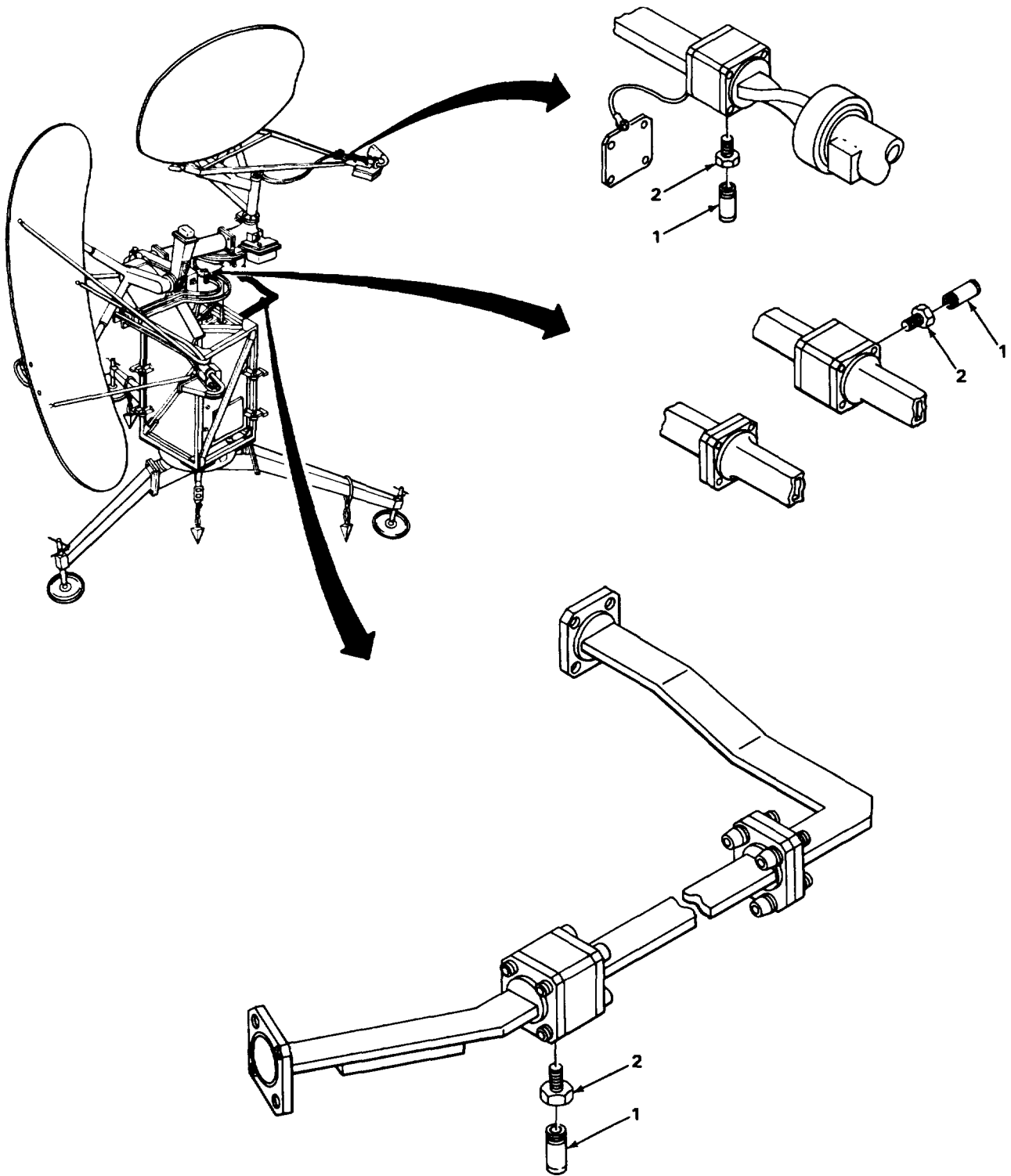

3-5. DEHYDRATOR CARTRIDGE INSPECTION. (CONT)

Three dehydrator cartridges (1) and their adapters (2) are located in three waveguides on the radar set group. These cartridges are replaceable and contain a desiccant (moisture absorbing material) that reduces moisture content within the waveguides. The desiccant is normally blue in color, but gradually loses its effectiveness and turns pink as it absorbs moisture. Replace the dehydrator cartridges when there is no trace of blue in the desiccant or when the color is definitely pink. Notify organizational maintenance when replacement is indicated by performance of the operator's weekly preventive maintenance checks and services.

3-6. OPERATIONAL CHECK.

Operational checks are used as a check to determine serviceability of radar set. The checks are performed after installation, and periodically as prescribed in organizational PMCS table. If a malfunction is found during a step in the operational check, report the problem to organizational maintenance personnel. The faulty part can then be isolated, tested, and repaired or replaced as necessary. Once corrective action has been taken, operational checks are performed again. Operational checks are divided into three parts. The first part checks the performance of receiver-transmitter and is performed at radar site. The second part checks master and slave control-indicator's performance. The third part checks operation of radar set group as a whole using operational controls on master control-indicator.

PRELIMINARY CONTROL SETTINGS

Before performing operational checks, make preliminary control settings as follows.

1. On both control-indicators, place the following controls to positions indicated:

| CONTROL | POSITION |
|-----------------------------------|------------------------|
| INTENSITY control | fully counterclockwise |
| FOCUS control | fully counterclockwise |
| POWER switch | OFF |
| TRANSMITTER switch | OFF |
| IF GAIN AZ and EL controls | fully counterclockwise |
| STC switch | OFF |
| FTC switch | OFF |
| PPI CENTERING NORM-OFFSET control | NORM |
| EL TARGET control | WIDE |
| VIDEO GAIN control | fully counterclockwise |

2. On each pulse generator, place the following controls to positions indicated:

| CONTROL | POSITION |
|---------------------|------------------------|
| SCAN MODE switch | SEARCH |
| SCAN switch | OFF |
| EL CURSOR switch | GP |
| ANGLE VOLTS switch | OPERATE |
| ART ANGLE V control | fully counterclockwise |
| RANGE MILES switch | 40 |
| ALTITUDE control | fully counterclockwise |

3-6. OPERATIONAL CHECK. (CONT)

PRELIMINARY CONTROL SETTINGS (CONT)

3. On receiver-transmitter main power panel, place the following controls to positions indicated.

| CONTROL | POSITION |
|-------------------|----------|
| MAIN POWER switch | OFF |
| AC OUTLETS switch | OFF |
| SCAN switch | OFF |
| HV switch | ON |

OPERATIONAL CHECKS TABLE

| ACTION | RESULT |
|---|---|
| PART 1 | |
| 1. On receiver-transmitter main power panel, place MAIN POWER switch to ON position. | Main power applied to radar set group indicated by operation of vent fans. Air, entering bottom of receiver-transmitter equipment case and exiting at receiver side, indicates proper ac power phasing. |
| 2. On local control monitor, place LOCAUL/REMOTE switch to LOCAL position. | Radar set group can now be controlled from receiver-transmitter site. |
| 3. On local control monitor, place SCAN MODE switch to SRCH position. | None. |
| 4. On receiver-transmitter main power panel, place SCAN switch to ON position. | Azimuth antenna scans clockwise (viewed from above) at approximately 16 rpm. |
| 5. On transmitter control panel, press LOCAL section of CONTROL LOCAL-REMOTE switch. | LOCAL section of indicator lights and XMTR LOCAL indicator DS5303 lights. |
| 6. On transmitter control panel, press INTERNAL section of TRIGGER SELECT INTERNAL-EXTERNAL switch. | INTERNAL section of indicator illuminates. |

3-4. OPERATIONAL CHECK. (CONT)

| ACTION | RESULT |
|--|-----------------------------------|
| 7. On transmitter control panel, press WIDE section of PULSE SELECT WIDE-NAR switch. | WIDE section of indicator lights. |
| 8. Use ANT SERVO control on local control monitor to tilt azimuth antenna up to its limit. | None. |

WARNING

To prevent exposure to hazardous rf radiation, make sure no personnel are within an 80-foot (24.5-m) radius of radar site when performing steps 9 and 10.

| | |
|---|---|
| 9. On transmitter control panel, press HV ON section of HV ON-HV READY indicator switch. | HV ON section of indicator illuminates. |
| 10. On local control monitor, place POWER SUPPLY (KILOVOLTS) - FILAMENT(VOLTS) switch to POWER SUPPLY (KILOVOLTS) position. | <ul style="list-style-type: none"> a. POWER SUPPLY VOLTS meter Indicates 3.4 + 0.4 kv. b. POWER SUPPLY CURRENT meter Indicates 260 + 50 ma. c. MAGNETRON CURRENT meter indicates 27.5 ± 5.5 ma. If any of the above results are Incorrect, refer to higher category of maintenance. |
| 11. On transmitter control panel, press HV OFF indicator switch. | <ul style="list-style-type: none"> a. HV ON section of Indicator will extinguish and HV READY section will light. If incorrect result is obtained, see paragraph 4-39. b. POWER SUPPLY VOLTS, POWER SUPPLY CURRENT, and MAGNETRON CURRENT meters indicate zero. If incorrect result is obtained, refer to higher category of maintenance. |
| 12. On transmitter control panel, press NAR section of PULSE SELECT WIDE-NAR indicator switch. | NAR section of indicator will illuminate and WIDE section will extinguish. If incorrect result is obtained, see paragraph 4-38. |

WARNING

To prevent exposure to hazardous rf radiation, make sure no personnel are within an 80-foot (24.5 m) radius of radar site when performing steps 13 and 14.

3-6. OPERATIONAL CHECK. (CONT)

OPERATIONAL CHECKS TABLE (CONT)

| ACTION | RESULT |
|---|--|
| <p>13. On transmitter control panel, press OVLD RESET indicator switch and press HV ON section of HV ON-HV READY indicator switch.</p> <p>14. On transmitter control panel press HV OFF switch.</p> | <p>a. HV ON section of indicator lights. b. POWER SUPPLY VOLTS meter indicates 3.4 ± 0.4 kv. c. POWER SUPPLY CURRENT meter indicates $100 + 10$ ma. d. MAGNETRON CURRENT meter indicates $9.5 + 1$ ma. If any of the above indications are incorrect, refer to higher category of maintenance.</p> <p>HV ON section of HV ON-HV READY will extinguish and HV READY section will light.</p> |
| <p><u>WARNING</u></p> | |
| <p>Be extremely careful to avoid being hit by scanning elevation antenna when performing step 15.</p> | |
| <p>15. On local control monitor, place SCAN MODE to following positions:</p> <p>a. NORM position</p> <p>b. 350 position</p> <p>c. 600 position</p> <p>d. SIM position</p> | <p>a. Azimuth antenna scans sector of 30 degrees and elevation antenna scans 11 degrees in elevation.</p> <p>b. Azimuth antenna scans sector of 30 degrees in azimuth and elevation antenna scans 35 degrees in elevation.</p> <p>c. Azimuth antenna scans sector of 60 degrees in azimuth and elevation antenna scans 11 degrees in elevation.</p> <p>d. Azimuth antenna scans sector of 360 degrees in azimuth and elevation antenna scans 11 degrees in elevation. If any of the results obtained above are incorrect, refer to higher category of maintenance.</p> |
| <p>16. On receiver-transmitter main power panel, place SCAN switch to OFF position.</p> | <p>Azimuth and elevation antennas stop scanning.</p> |
| <p>17. On local control monitor, place ANT SERVO control to following positions:</p> <p>a. UP position</p> <p>b. DOWN position</p> <p>c. L position</p> <p>d. R position.</p> | <p>a. Azimuth antenna tilts up to + 25 degree limit and stops.</p> <p>b. Azimuth antenna tilts down to - 1 degree limit and stops.</p> <p>c. Elevation antenna servos to + 15 degree limit and stops.</p> <p>d. Elevation antenna servos to - 15 degree limit and stops.</p> <p>If any of the results obtained above are incorrect, refer to higher category of maintenance.</p> |

3-4. OPERATIONAL CHECK. (CONT)

| ACTION | RESULT |
|--|--|
| 18. On transmitter control panel, press REMOTE section of CONTROL LOCAL-REMOTE indicator switch. | Remote section of switch lights and XMTR REMOTE indicator on local control monitor lights. |
| 19. On local control monitor, place LOCAUREMOTE switch to IND position. | None. |

PART 2

| | |
|--|--|
| 20. On receiver-transmitter panel, place SCAN switch to ON position. | None. |
| 21. On both control-indicators, place POWER circuit breaker to ON position. | Vent fans at back of control-indicators operate and front panel lamps on control-indicators and pulse generators illuminate. |
| 22. On both control-indicators, place BITE-AZ TILT meter select switch to AZ TILT position. | AZ TILT/BITE meter Indicates azimuth antenna tilt angle. |
| 23. On master control-indicator, place ANTENNA switch to U and D positions while observing AZ TILT/BITE meter on both control-indicators. | AZ TILT/BITE meter needle goes up when ANTENNA switch is in U position and goes down when ANTENNA switch is in D position. If results obtained are incorrect, refer to higher category of maintenance. |
| 24. On master control-indicator, use ANTENNA switch as necessary to tilt azimuth antenna to zero degrees as indicated on AZ TILT/BITE meter. | None. |
| 25. On master control-indicator, place ANT POL switch to CIR position. | LIN indicator lamp is extinguished and CIR indicator lamp is illuminated on both control-indicators. |
| 26. On master control-indicator, place ANT POL switch to LIN position. | CIR indicator lamp is extinguished and LIN indicator lamp is illuminated. |
| 27. On master control-indicator, place SCAN MODE switch to SEARCH position. | Stationary time base appears on both control-indicators. |

3-6. OPERATIONAL CHECK. (CONT)

OPERATIONAL CHECKS TABLE (CONT)

| ACTION | RESULT |
|---|--|
| 28. On both control-Indicators, adjust FOCUS and INTENSITY controls as necessary for a sharp, well-defined sweep. | Adequate control of sweep intensity level and focus. If above result cannot be obtained, refer to higher category of maintenance. |
| 29. On both control-indicators, adjust VIDEO GAIN control fully counterclockwise. | None. |
| 30. On master control-indicator, place SCAN switch to ON position. | Ppi sweep rotates clockwise on both control-indicators. |
| 31. On both control-Indicators, place RANGE MILES switch to position 20. | Ppi display with 20-mile range on both control-indicators. |
| 32. On master control-indicator, rotate IF GAIN AZ and EL controls fully clockwise. | Receiver noise (grass) appears on ppi display on both control-indicators. |
| <p><u>WARNING</u></p> | |
| <p>To prevent exposure to hazardous rf radiation, make sure no personnel are within an 80-foot (24.5 m) radius of radar site when performing steps 33 through 36.</p> | |
| 33. On master control-indicator, place TRANSMITTER switch to WIDE PLS position and press HV ON indicator switch. | HV ON indicator switch lights. |
| 34. On master control-indicator, place SCAN switch to OFF position to stop azimuth antenna scan on any convenient ground return. | Ppi sweep stops rotating on both control-indicators. Ground return appears in same position on ppi display of both control-indicators. |
| 35. On master control-indicator, adjust LO TUNE control for maximum radar video return on both control-indicators. | Maximum radar video return appears on both control-indicators. |

3-6. OPERATIONAL CHECK. (CONT)

| ACTION | RESULT |
|---|--|
| 36. On both control-indicators, rotate VIDEO GAIN control clockwise until radar video begins to defocus (bloom) then rotate slightly counter-clockwise. | Well-defined radar video just below bloom level on both control-indicators. |
| 37. On master control-indicator, place TRANSMITTER switch to OFF position. | Radar transmitter no longer transmitting. |
| 38. On both control-indicators, place PPI CENTERING NORM- OFFSET switch to OFFSET position. | Ppi display changes to offset centering on both control- indicators. |
| 39. On both control-indicators, rotate PPI CENTERING VERT and HORIZ control knobs through their ranges. | Adequate range of controls to offset ppi center to edge of display at all compass rose bearings. |
| 40. On both control indicators, place PPI CENTERING NORM- OFFSET switch to NORM position and adjust VERT and HORIZ controls to center ppi sweep. | Ppi sweep centered on both control-indicators. |
| 41. On master pulse generator, place SCAN switch to ON position. | Ppi sweep rotates clockwise on both control-indicators. |
| 42. On both pulse generators, place RANGE MILES switch to each of its positions in turn. | Proper sweep lengths and correct number and linear spacing of range marks occur for each switch position. |
| 43. On both pulse generators place RANGE MILES switch to position 10. On master pulse generator, place SCAN MODE switch to NORM position. | Presentation changes from ppi to beta display on both control-indicators. Each display has an elevation and azimuth cursor, servo data Information (blanked sector in range marks), and properly spaced range marks. |
| 44. On both pulse generators, place ANGLE VOLTS switch to EL position. | Artificial sweep trace appears on elevation display on both control-indicators. |
| 45. On both pulse generators, place ANGLE VOLTS switch to AZ position. | Artificial sweep trace appears on azimuth display of both control-indicators. |

3- OPERATIONAL CHECK. (CONT)

OPERATIONAL CHECKS TABLE (CONT)

| ACTION | RESULT |
|--|--|
| 46. On both pulse generators, return ANGLE VOLTS switch to OPERATE position. | Beta scan reappears on both control-indicators. |
| 47. On both pulse generators, place EL CURSOR switch to HF position. | Height finder cursor appears on elevation display on both control-indicators. |
| 48. On both pulse generators, rotate ALTITUDE control fully counterclockwise. | ALTITUDE indicator window indicates field elevation. |
| 49. On both pulse generators, rotate ALTITUDE control clockwise through its range. | Height finder cursor moves upward on elevation display of both control-indicators. |

PART 3

| | |
|---|--|
| 50. On master pulse generator, place SCAN MODE switch to 350 EL position. | Elevation display changes from 11- to 36-degree presentation on both control-indicators. |
| 51. On master pulse generator, place SCAN MODE switch to 600 AZ position. | Azimuth display changes from 30- to 60-degree presentation on both control-indicators. |
| 52. On master pulse generator, place SCAN MODE switch to SIMULT position. | Presentation on slave control-indicator changes from beta to ppi display. Beta scan remains on master control-indicator. |

NOTE

If associated IFF equipment is being used, perform step 53. If associated IFF equipment is not being used, proceed to step 54.

| | |
|---|--|
| 53. On master pulse generator, place SCAN MODE switch to IFF position. | Ppi presentation on both control-indicators. |
| 54. On master pulse generator, place SCAN MODE switch to NORM position. | Beta presentation with 10-mile range on both control-indicators. |

36. OPERATIONAL CHECK. (CONT)

| ACTION | RESULT |
|--------|--------|
|--------|--------|

WARNING

To prevent exposure to hazardous rf radiation, make sure no personnel are within an 80-foot (24.5 m) radius of radar site when performing steps 56 through 58.

| | |
|--|--|
| 55. On master control-indicator, place TRANSMITTER switch to WIDE PLS position and press HV ON indicator switch. | Radar transmitter transmitting. |
| 56. On master pulse generator, place SCAN switch to OFF position, stopping antenna scan on any convenient ground return. | Beta scans stop on azimuth and elevation displays. Ground target return visible on stationary beta scans on both control-indicators. |
| 57. On master control-indicator, place TRANSMITTER switch to NAR PLS position and press HV ON indicator switch. | Width of ground target return decreases on beta displays on both control-indicators. |

NOTE

Perform steps 58 through 67 when operating radar set in areas where heavy precipitation is common. These checks test the ability of radar set to reduce clutter, and therefore can only be performed when precipitation or ground clutter is present on radar displays.

| | |
|---|---|
| 58. On master control-indicator, place ANT POL switch to CIR position. | LIN indicator lamp extinguishes and CIR indicator lamp lights on both control-indicators. Any precipitation clutter on radar displays is reduced. |
| 59. On master control-indicator, return ANT POL switch to LIN position. | CIR indicator lamp extinguishes and LIN indicator lamp lights on both control-indicators. |
| 60. On master control-indicator, place FTC switch to LIN position. | Large blocks of ground and precipitation clutter are reduced, with only leading edge of radar returns visible on both control-indicators. |
| 61. On master control-indicator, place FTC switch to LOG position. | Blocks of ground and precipitation clutter are further reduced. |
| 62. On master control-indicator, place STC switch to ON position. | Strength of close-in radar returns decreases on both control-indicators. |

3-6. OPERATIONAL CHECK. (CONT)

OPERATIONAL CHECKS TABLE (CONT)

| ACTION | RESULT |
|---|--|
| 63. On master control-indicator, return STC switch to OFF position | Strength of close-in radar returns return to normal on both control-indicators. |
| 64. On master control-indicator, rotate IF GAIN AZ and EL controls fully counter-clockwise. | Radar returns disappear on both control-indicators. |
| 65. On master control-indicator, rotate IF GAIN AZ and EL controls fully clockwise. | Radar returns reappear with noise (grass) in background on both control-indicators. |
| 66. On master control-indicator, rotate EL TARGET control clockwise toward NARROW position. | Vertical height of close-in radar returns decreases as EL TARGET control is rotated toward NARROW position. |
| 67. On master control-indicator, place ANTENNA control to the following positions: a. U position b. D position c. L position d. R position. | a. AZ TILT/BITE meters indications increase and blanked portion of range marks on elevation displays go up. b. AZ TILT/BITE meters indications decrease and blanked portion of range marks on elevation displays go down. c. Blanked portion of range marks on azimuth displays go down. d. Blanked portion of range marks on azimuth displays go down. |

37. FRONT PANEL AND INDICATOR LAMP REPLACEMENT.

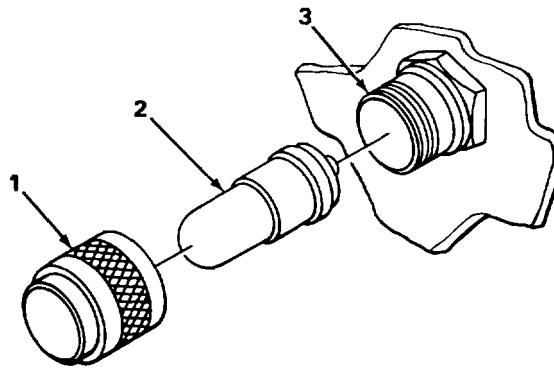

3-7. FRONT PANEL AND INDICATOR LAMP REPLACEMENT. (CONT)**NOTE**

Most front panel and indicator lamps on control-indicators and local control monitor have a push-to-test feature. Before replacing a lamp, press jewel assembly to test lamp.

REMOVAL

1. Unscrew jewel assembly (1) and lamp (2) from lamp socket (3).
2. Remove defective lamp (2) from jewel assembly (1).

REPLACEMENT

1. Insert new lamp (2) into jewel assembly (1).
2. Screw jewel assembly (1) and lamp (2) into socket (3).
3. Check new lamp (2) by pressing jewel assembly (1) and observing that lamp lights.

3-8. FUSE REPLACEMENT.

All fuses used in radar set have a blown-fuse indicator lamp inside fuse holder cap that will light when corresponding fuse blows. Indicator lamps are an integral part of fuse holder and are not replaceable.

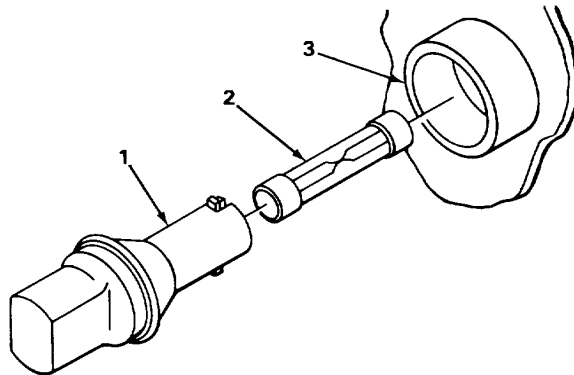

305NE171

CAUTION

Always replace blown fuse with one of same rating. If replacement fuse blows, do not install another fuse until trouble has been corrected.

REMOVAL

1. Push fuse holder (1) in and turn counterclockwise.
2. Remove fuse holder (1), containing fuse (2), from fuse receptacle (3).
3. Remove fuse (2) from fuse holder (1).

REPLACEMENT

1. Insert new fuse (2) into fuse holder (1).
2. Insert fuse holder (1) into fuse receptacle (3).
3. Push fuse holder (1) in and turn clockwise to lock into place.

3-21(3-22 blank)

CHAPTER 4

ORGANIZATIONAL MAINTENANCE

| Subject | Section | Page |
|--|---------|-------|
| Repair Parts, Special Tools, TMDE, and Support Equipment | I | 4-1 |
| Service Upon Receipt | II | 4-1 |
| Organizational Preventive Maintenance Checks and Services (PMCS)..... | III | 4-103 |
| Organizational Troubleshooting..... | IV | 4-105 |
| Organizational Maintenance Procedures | V | 4-117 |
| Preparation for Storage and Shipment | VI | 4-155 |

Section I REPAIR PARTS, SPECIAL TOOLS, TMDE, AND SUPPORT EQUIPMENT

| Subject | Para | Page |
|---|------|------|
| Common Tools and Equipment | 4-1 | 4-1 |
| Special Tools, TMDE, and Support Equipment..... | 4-2 | 4-1 |
| Repair Parts | 4-3 | 4-1 |

4-1. COMMON TOOLS AND EQUIPMENT

A complete listing of common tools and equipment is given in the Maintenance Allocation Chart (MAC), appendix B at the back of this manual

4-2. SPECIAL TOOLS, TMDE, AND SUPPORT EQUIPMENT

There are no special tools required to maintain Radar Set AN/TPN-18A

4-3. Repair parts for organizational maintenance of Radar Set AN/TPN-18A are listed and illustrated in the repair parts and special tools list in TM 11-5840-281-20P-1

Section II SERVICE UPON RECEIPT

| Subject | Para | Page |
|--|------|------|
| General..... | 4-4 | 4-2 |
| Site and Shelter Requirements..... | 4-5 | 4-2 |
| Unpacking..... | 4-6 | 4-12 |
| Radar Set Assembly and Installation Instructions | 4-7 | 4-21 |
| Antenna Pedestal Assembly..... | 4-8 | 4-22 |
| Azimuth Antenna Drive Assembly | 4-9 | 4-23 |
| Azimuth Antenna Assembly..... | 4-10 | 4-24 |
| Elevation Antenna Assembly..... | 4-11 | 4-26 |
| Antenna Pedestal Installation | 4-12 | 4-28 |
| Receiver-Transmitter Group Installation..... | 4-13 | 4-30 |
| Elevation Antenna Drive Installation..... | 4-14 | 4-31 |

Section II SERVICE UPON RECEIPT (CONT)

| Subject | Para | Page |
|---|------|------|
| Azimuth Antenna Drive and Yoke Assembly Installation..... | 4-15 | 4-32 |
| Azimuth Antenna Installation..... | 4-16 | 4-33 |
| Elevation Yoke Assembly Installation..... | 4-17 | 4-34 |
| Elevation Antenna Installation..... | 4-18 | 4-35 |
| Waveguides Installation..... | 4-19 | 4-36 |
| Siting Scope Installation..... | 4-20 | 4-43 |
| Clinometer Installation..... | 4-21 | 4-44 |
| Indicator Rain Shields and Deflectors Installation..... | 4-22 | 4-45 |
| Interconnecting Cables..... | 4-23 | 4-46 |
| Radar Set Group Leveling..... | 4-24 | 4-52 |
| Ground Angle Determination..... | 4-25 | 4-53 |
| Siting of Target Simulators..... | 4-26 | 4-55 |
| Preliminary Servicing and Adjustment..... | 4-27 | 4-68 |
| Circuit Alinement..... | 4-28 | 4-85 |

4-4. GENERAL.

This section explains what must be done upon initial receipt of radar set. Procedures appear in the order in which they are to be performed.

Contents are first removed from crates and shipping frames and checked against the packing list for any discrepancies. Contents also are checked for damage that might prevent equipment from performing its mission. If a minor discrepancy or damage is found that will not affect the operation of equipment, put the equipment into service. Report your findings on SF 361, Discrepancy in Shipping Report (DISREP), as prescribed in AR 55-38, Report of Transportation Discrepancies in Shipping Report. If no discrepancies or damages are found, proceed with component assembly and installation. After the radar set has been assembled and installed, perform the ground angle determination, preliminary services and adjustments, radar target simulators siting, and cursor alinement procedures.

Personnel are listed only if the task requires more than one technician. These tasks can be performed by operator personnel, except when maintenance personnel are specifically required. Maintenance personnel should be present to assist as required.

Resources required are not listed unless they apply to a specific procedure.

Observe all WARNINGS, CAUTIONS, and NOTES to prevent injury to personnel and damage to equipment.

4-5. SITE AND SHELTER REQUIREMENTS.

Location of radar set group is of prime importance in planning siting and installation of radar set and radar target simulators. Single, parallel, or multiple runway coverage, length of runways, distance between runways, and location of taxiways are all limiting factors in selecting the best radar site.

Other Important factors to be considered when selecting the radar site include the following:

- Terrain
- Line-of-site obstructions
- Accessibility

4-5. SITE AND SHELTER REQUIREMENTS. (CONT)

- Air traffic patterns and flow
- Routing of interconnecting cables
- Positioning of power supplies
- Location of control-indicator groups
- Applicable governing regulations and standard operating practices (SOP)
- Equipment siting limitations

TERRAIN

It is essential that radar set group be kept level at all times so that antenna tilt information and preset cursor alignments will remain accurate in any direction. Select a radar site that is level, well drained, and firm enough to support weight of radar set group. Leveling adjustments in leg of antenna pedestal can compensate for an Incline of 2.5 degrees maximum. Use a concrete slab or wooden planks to keep radar set group level in a permanent or semipermanent configuration. In a tactical situation, use ground anchors and tiedown straps. Location of structures such as taxiways and drainage culverts will influence radar site selection. Whenever possible, select a radar site that is at same ground level as td. If the radar site elevation is higher than td, the ground angle between the two must not exceed -1 degree. When the radar site elevation is lower than td, the limiting factor is radar coverage as described in Line-of-Site Obstructions.

LINE-OF-SITE OBSTRUCTIONS

Radar set operates in that part of the frequency spectrum that exhibits line-of-site propagation. Therefore, any part of the area that cannot be viewed from the radar site will also be "blind" to radar. It is thereby essential that radar set group have an unobstructed view of the area to be covered by radar. Complete azimuth and elevation radar coverage is always desired; however, objects such as trees, buildings, and hills will sometimes obscure low-level coverage in some azimuth bearings. Give special consideration so these objects do not obscure the azimuth sector containing the final approach area, the entrance to final approach area, and the radio frequency aids-to-navigation pickup points.

ACCESSIBILITY

Select a radar site and operating site that will permit access by personnel and equipment for maintenance and primary power generator refueling. Route interconnecting cables so that they are out of the way or protected from heavy equipment traffic.

TRAFFIC PATTERNS AND FLOW

Radar siting requirements become more stringent when approaches to more than one runway of an airfield are used. In multiple runway coverage, traffic patterns and maximum traffic flow determine the location of radar set group. If one runway is designated as the primary gca runway, it should be given adequate coverage even at the expense of the other runway approaches.

APPLICABLE REGULATIONS

Select and locate the radar site in accordance with applicable regulations and standard operating procedures. Be sure that any limits or restrictions on radar equipment and the site selected are not violated without proper authority.

4.5. SITE AND SHELTER REQUIREMENTS. (CONT)

EQUIPMENT SITING LIMITS

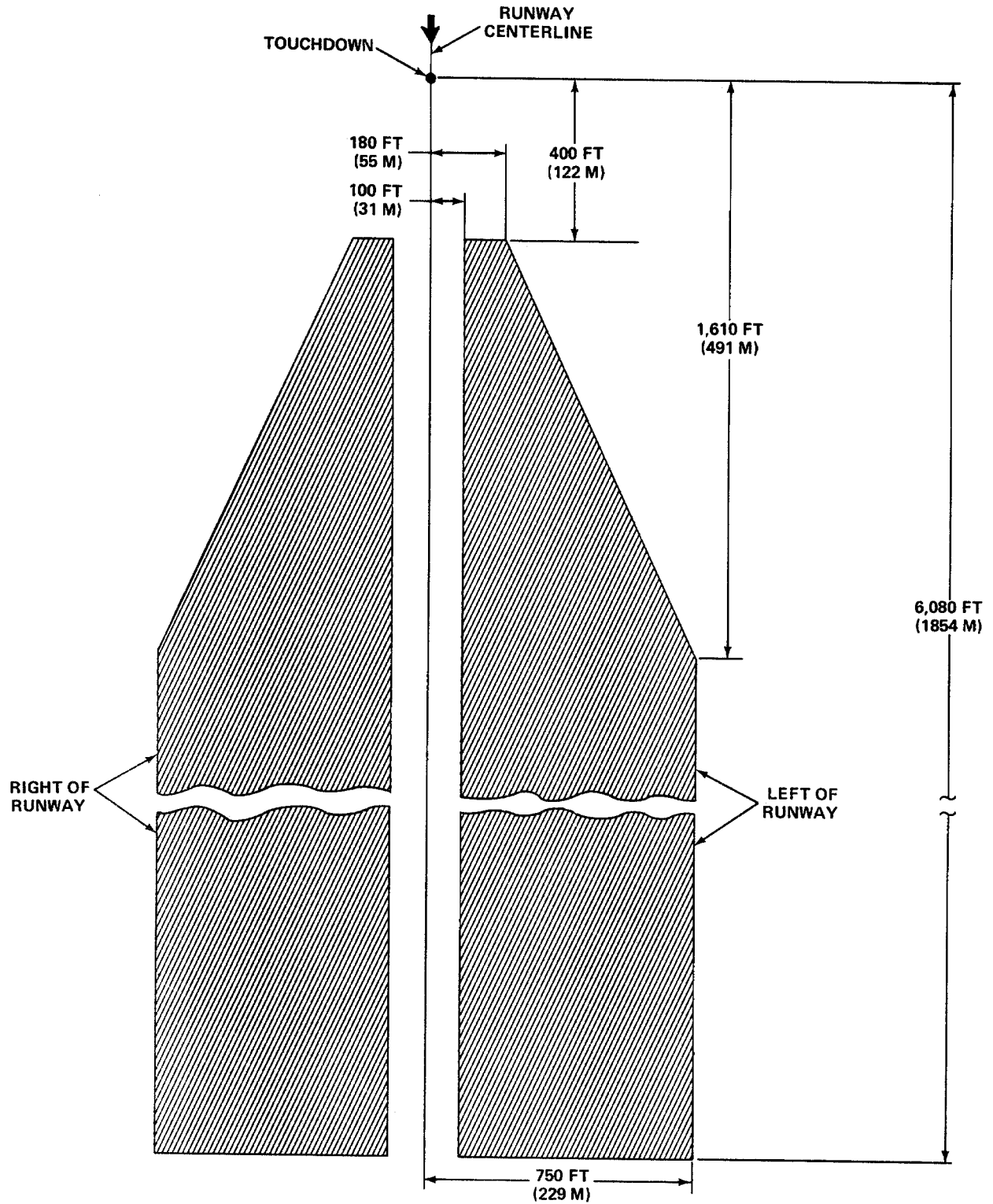

305NE073

4-5. SITE AND SHELTER REQUIREMENTS. (CONT)

Equipment siting limits are determined by display resolution, aggregate system accuracies, and mechanical scan limits of antennas. Radar set group should be located between 400 and 6080 feet (122 and 1854 m) from td point and 100 and 750 feet (31 and 229 m) offset from centerline of runway. These limits form boundaries (one for right-of-runway, one for left-of-runway) in which radar set group should be located to function properly for a single runway approach.

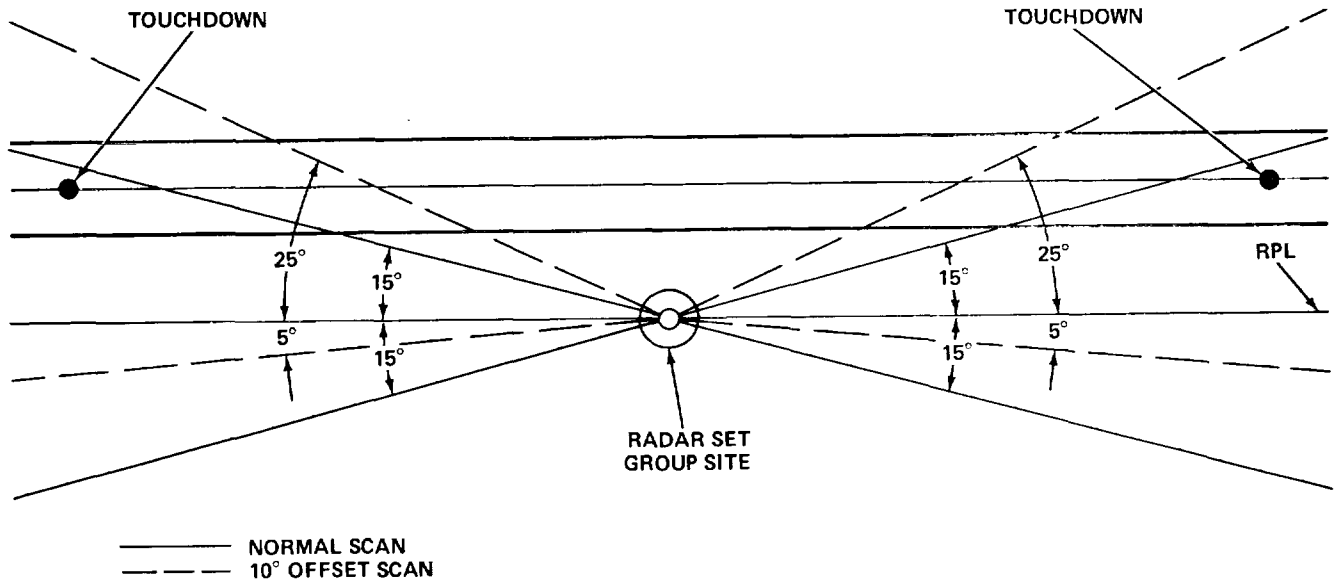

305NE074

Ideal runway approach coverage is obtained when the azimuth antenna scans 15 degrees (solid lines) to each side of the rpl. When the situation warrants, the azimuth scan may be offset a maximum of 10 degrees (dotted lines) toward the runway to provide better landing approach corridor coverage.

Notice that dimensions listed define a definite rectangle, but siting areas shown (page 4-4) have a corner of the rectangle missing. The reason for this is that when radar set group is located less than 1,610 feet (491 m) from td point, the maximum offset distance is limited by the precision approach (30-degree sector) scan of the azimuth antenna. During precision approach, the azimuth scan must include the td point and the landing approach corridor. When the azimuth antenna is offset 10 degrees (dotted lines), then 25 degrees of the azimuth scan will be on the runway side of the rpl and will include the td point. Therefore, if a line is extended from the td point at an angle of 25 degrees to the clr, it will intersect at a maximum offset distance of 180 feet (55 m) at 400 feet (122 m) from td and a maximum offset distance of 750 feet (229 m) at 1,610 feet (491 m) from td. These dimensions form the actual boundaries (page 4-4) for siting radar set group.

4-5. SITE AND SHELTER REQUIREMENTS. (CONT)

RUNWAY SITING CONFIGURATIONS

Single Runway Siting

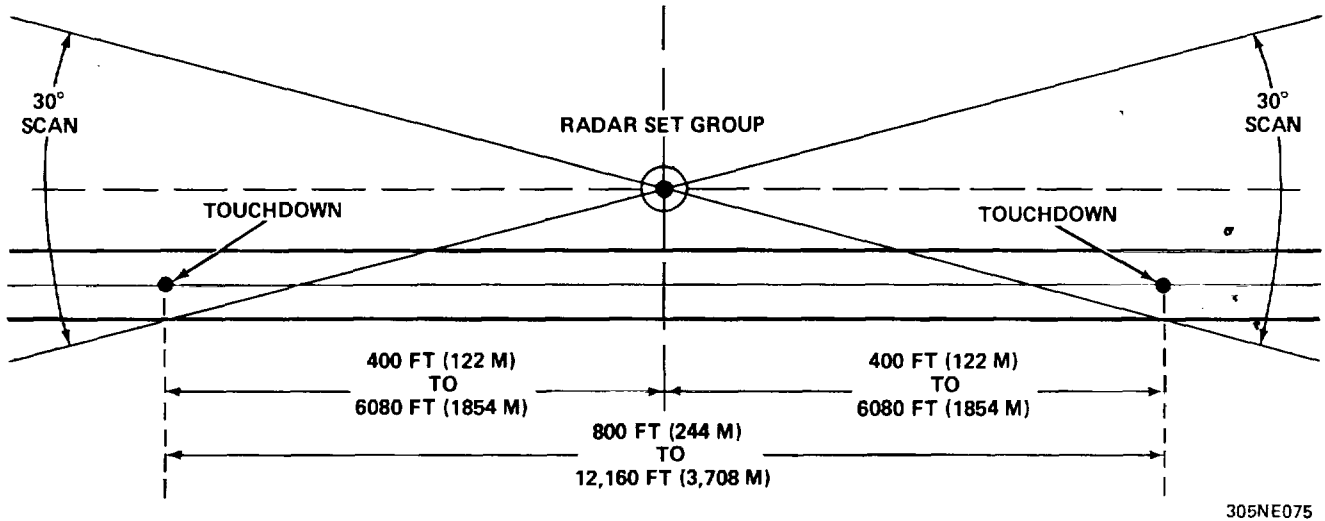

Gca landing service can be provided to both ends of a single runway by locating radar set group mid-way between the ends of the runway. In the figure above, the td point is located within the 30 normal scan (15 degrees left of rpl, 15 degrees right of rpl) of the azimuth antenna on both approaches. If the situation warrants, the azimuth scan may be offset up to 10 degrees toward the runway for either one or both of the approaches to provide better landing approach corridor coverage. If radar set group is located midway between the two td points, then the minimum and maximum distances between td points are 800 feet (244 m) and 1,360 feet (415 m), respectively. The 800-foot (244 m) minimum distance between td points is obtained by taking the minimum distance from radar set group to td point of 400 feet (122 m) and doubling it. The 12,160-foot (3,708 m) maximum distance between td points is obtained by taking the maximum distance from radar set group of 6,080 feet (1854 m) to td point and doubling it.

Parallel Runway Siting

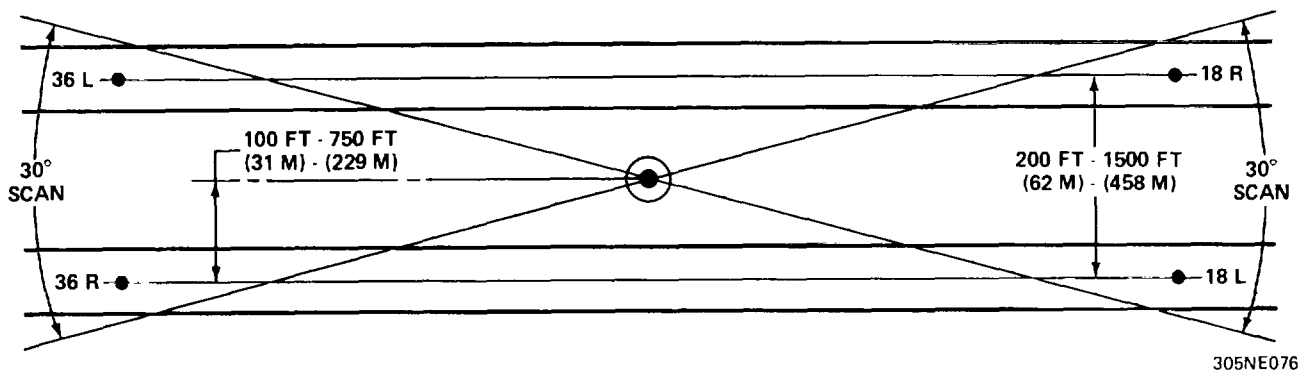

4-5. SITE AND SHELTER REQUIREMENTS. (CONT)

Optimum parallel runway coverage is obtained when radar set group is located midway between the two runways. In this case, the 30-degree normal scan of the azimuth antenna covers the td point and landing approach corridor for two runways at a time (18R with 18L and 36L with 36R). In order for gca landing service to be provided for both ends of both runways, the minimum and maximum distance separating the runways (measured from the clr) must be 200 feet (71 m) and 1,500 feet (458 m), respectively. The 200-foot (71 m) minimum separation distance is obtained by doubling the minimum offset distance of 100 feet (131 m). The 1,500-foot (458 m) maximum separation distance is obtained by doubling the maximum offset distance of 750 feet (229 m). The minimum and maximum distances between touchdown points are the same as the ones for single runway siting.

Multiple Runway Siting

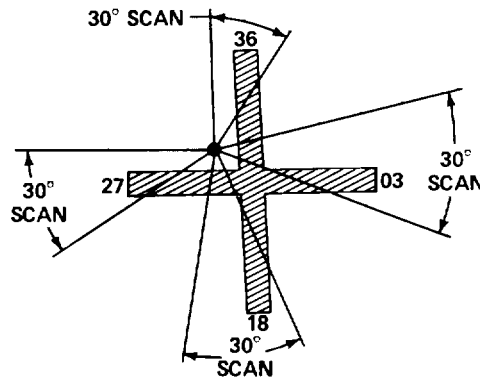

305NE077

If the runway layout forms a cross, radar set group may be located in any one of the four quadrants, as shown in the figure above. Radar set will provide complete coverage for any one of the four possible approaches from all four of these quadrants, providing that all equipment siting limits are met.

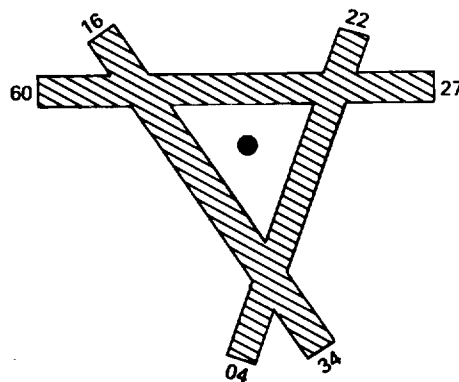

305NE078

When the runway layout forms a triangle, the radar site location shown above is the only one that will provide complete coverage to any one of the six possible approaches. This is true providing that all equipment siting limits are met.

4-5. SITE AND SHELTER REQUIREMENTS. (CONT)

RUNWAY SITING CONFIGURATIONS (CONT)

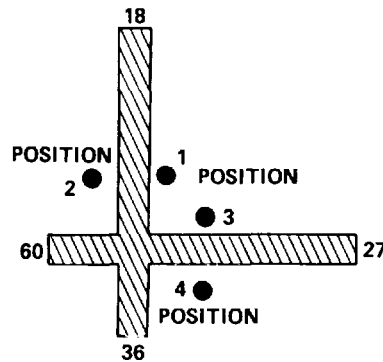

305N E079

NOTE

Runway numbers usually, but not always, indicate magnetic heading of runway. Therefore, the number 18 indicates a magnetic heading of 180 degrees for that runway.

It is difficult to cover all four approaches to two runways when they form right angles by intersecting at offcenter points, as shown in the figure above. Positions 1 and 2 readily cover runways 18, 27, and 36, but are too close to the end of runway 09 to provide proper coverage. Positions 3 and 4 provide complete coverage for runways 09, 18, and 27 but are too close to the end of 36 to provide adequate coverage.

EQUIPMENT COMPONENT LOCATION

NOTE

Refer to TM 11-5895-474-12 addendum for location of components and routing of interconnecting cables when installing radar set in Landing Control Central AN/TSQ-71 B.

Control Indicator Group

When not installed as part of a landing control system, the two control-indicator groups may be located up to the maximum distances permitted by interconnecting cables. The video, control data, and pretrigger cables (W3001, W3002, and W3005) connecting the master control-indicator group to radar set group are 250 feet long; the ac power cable (W3003) connecting the master control-indicator group to the ac power distribution box is 135 feet long. The power, video, control data, and pretrigger cables (W9501, W9502, W9503, and W9504) connecting the slave control-indicator group to the master control-indicator group are 25 feet long.

Primary AC Power Generator and AC Power Distribution Box

The primary ac power generator (not part of radar set or landing control system) must be easily accessible for refueling. The ac power distribution box must be within 8 cable feet of the primary ac generator and within 135 cable feet of receiver-transmitter group and master control-indicator group to allow connection of ac power cables W3003, W3004, and W3007.

4-5. SITE AND SHELTER REQUIREMENTS. (CONT)**EQUIPMENT SITING PROCEDURES**

Two equipment siting procedures are given below. The first procedure requires less time but does not include a check for excessive negative ground angle. It is used when a map and theodolite or transit are not available, or when time will not permit use of the second method. The second procedure uses a map and theodolite or transit; it is more precise and eliminates the possibility of relocating radar set group due to excessive negative ground angle. In the following procedures, radar site refers to the specific location of radar set group and operating site refers to the specific location of control-indicator groups.

Siting Without Theodolite or Transit

The following siting procedure accomplishes the same objective as the procedure using a map and theodolite or transit, with two exceptions: it does not include a check for excessive negative ground angle, and it does not include a precise radar coverage check for inadequate radar coverage due to obstructions. When this procedure is used, radar coverage and excessive negative ground angle checks are made after radar set is installed. These checks are made using siting scope and clinometer, which mount on azimuth and elevation antennas, and are supplied as part of radar set group.

1. Select a runway configuration from Runway Siting Configurations (para 4-5) that best represents the configuration of airfield. Relate location of radar site on illustration to its location on airfield.
2. Proceed to appropriate location of radar site on airfield; check that all requirements for Terrain (para 4-5), Accessibility (para 4-5), and Equipment Component Locations (para 4-5) are satisfied.

NOTE

If all requirements are satisfied, proceed with step 3; if not, visually survey surrounding area for another location that will satisfy above requirements; 3. Visually determine through 360 degrees in azimuth that no apparent radar target obstructions exist that will prevent adequate radar coverage. Give special consideration to approach zones to runways.

NOTE

If there are no apparent obstructions visible, proceed with step 4. If an obstruction is observed, relocate radar site to an area where no apparent obstructions are visible and repeat procedure, starting with step 2.

4. Measure distances from center of radar set to CLR and from center of radar set to a point on RPL directly opposite to point to ensure radar site selected is within perimeters established in Equipment Siting Limits (para 4-5).

NOTE

If radar site is within equipment siting limits, proceed with step 5; if not, select new radar site that is within siting limits and repeat procedure beginning with step 2.

5. Mark radar site for equipment installation.

4-5. SITE AND SHELTER REQUIREMENTS. (CONT)**EQUIPMENT SITING PROCEDURES (CONT)**

6. Select operating site in accordance with requirements for Accessibility (para 4-5) and Equipment Component Location (para 4-5).
7. Mark locations for equipment to be installed at operating site.

Siting Using Theodolite or Transit**NOTE**

When siting using a theodolite or transit, two personnel are required to perform steps 11 and 12.

1. Review all applicable regulations, SOPs, and other information that govern equipment siting or otherwise restricts or imposes limits (distance to runway edges and prohibitions against siting in lateral safety zones).
2. On scaled map of airfield, measure and lay out equipment siting perimeters determined in Equipment Siting Limits (para 4-5) for each approach to be covered by gca service. Draw these boundaries to scale of the map.
3. On map, shade all areas of equipment siting boundaries that are common (overlapping). Shaded areas are areas in which radar set group can be located to provide adequate coverage for all approaches being considered for gca service.
4. On map, lay out all elements of airfield, such as parking aprons, taxiways, access roads, runway clear areas, hard stands, storage areas, revetments, drainage culverts, and any navigational aides that may conflict with location of equipment siting.
5. On map, determine azimuth and elevation positions of any buildings, structures, hills, or other possible obstructions to radar coverage.
6. Select radar site within common shaded areas in step 3 that will provide adequate coverage to all approaches being considered for gca service.

NOTE

Be sure radar site selected does not conflict with physical location of components of airfield in steps 4 and 5. If no conflicts exist, proceed with step 7; if a conflict exists, select new radar site and repeat procedure, beginning with step 6.

7. Proceed to general area and locate exact position of radar site by measuring distance from known points, such as clr, or by triangulation with a theodolite (location of a point by means of bearings taken from two fixed points a known distance apart).
8. Check that all requirements for Terrain (para 4-5), Accessibility (para 4-5), and Equipment Component Location (para 4-5) are satisfied.

NOTE

If all requirements are satisfied, proceed to step 9; if not, select new radar site and repeat procedure, starting with step 6.

4.5. SITE AND SHELTER REQUIREMENTS. (CONT)

9. Set up theodolite at center of radar site selected. Be sure theodolite is level.
10. Site theodolite on horizon and rotate through 360 degrees in azimuth. Measure angles of any obstructions to line-of-sight view. Give special consideration to coverage of approach zones to runways.

NOTE

Dimensions of approach zones vary with size of airfield. If not known, obtain dimensions from a higher authority.

11. Mark a stadia rod or pole at same height as that of theodolite telescope.
12. Direct second person to hold stadia rod or pole in a vertical position on td point. Site horizontal crosshair of theodolite on mark made in step 11. If radar site is higher than td point, be sure negative ground angle does not exceed - 1 degree. Repeat this for each runway being considered for gca service.

NOTE

If all requirements of steps 10 and 12 are satisfied, proceed with step 13; if not, select new radar site and repeat procedure starting with step 6.

13. Mark exact center of radar site for equipment installation.
14. Select an operating site in accordance with the requirements for Accessibility (para 4-5) and Equipment Component Location (para 4-5).
15. Mark locations for equipment to be installed at operating site.

SHELTER REQUIREMENTS

Radar set is functionally operational without any shelter or associated equipment. However, when radar set is to be operated as part of a gca and air traffic control facility, a shelter is needed to house radio communication, IFF, and other associated equipment. Refer to TM 11-5895-474-12 addendum when radar set is being installed as part of Landing Control Central AN/TSQ-71B.

4-6. UNPACKING.

Radar set is shipped encased in metal frames, steel drums, and wooden crates. It is received in one of two conditions, depending on the method of transportation. When transported over short distances, such as by helicopter or truck, the control-indicators groups and receiver-transmitter are received installed in their own weatherproof cases, which are mounted in tubular shipping frames. Antennas and mechanical assemblies are received packed in two shipping frames. When being shipped over long distances, such as by cargo airlift, railroad, or cargo vessel, these shipping frames, along with the control-indicators groups and receiver-transmitter, are received packaged separately in wooden crates. Small parts and hardware, such as waveguides, ground anchors, and mounting hardware, are packed in two drums. The antenna pedestal is received strapped in a folded position and requires no shipping container. Interconnecting cables are received on six reels.

4-6. UNPACKING. (CONT)

PACKAGING DATA

The drum or frame numbers, sizes, weights, volumes, and contents of the shipping frames are indicated in the table below. This table does not replace the packing slip shipped with the radar set; PACKAGING DATA however, it can be used as an aid when unpacking and checking equipment.

| CONTAINER NO. | QTY | NAME OR NOMENCLATURE | MFR PART NO. | DIMENSIONS (IN./CM) | | | WEIGHT (LB/KG) | |
|---------------|-----|--|---|---------------------|---------------|--------------|----------------|----------------|
| | | | | LENGTH | WIDTH | DEPTH | | |
| 1 | 1 | Antenna Reflector Shipping Frame No. 1 | 103202 | 101/ 256.54 | 54/ 137.16 | 33/ 83.82 | 498/ 226.09 | |
| | 1 | Azimuth Antenna Reflector | 100227 | | | | | |
| | 1 | Azimuth Horn and Polarizer Support | 102948 | | | | | |
| | 1 | Elevation Antenna Reflector | 100229 | | | | | |
| | 1 | Elevation Horn and Polarizer Support Arm | 102861 | | | | | |
| | 1 | Elevation Horn and Polarizer Support Arm | 102838-1 | | | | | |
| | 1 | Elevation Horn and Polarizer Support arm | 102838-2 | | | | | |
| | 1 | Reflector and Support Assembly | 102754 | | | | | |
| | 3 | Polarizer Assembly | 102755 | | | | | |
| | 3 | Post | 102756-4 | | | | | |
| | 9 | Legs | 102756-5 | | | | | |
| | 1 | Ground Rod | 112402 | | | | | |
| | 1 | Drive Rod, 3 ft | G500001-1 | | | | | |
| | 2 | 1 | Drive Rod, 4 ft | G500001-2 | | | | |
| | | | Antenna Drive Assembly Shipping Frame No. 2 | 103201 | 56/ 142.24 | 33/ 83.82 | 33/ 83.82 | 440/ 199.76 |
| | | 1 | Antenna Drive TG-230/TPN-18 | 170293-1 | | | | |
| | | 1 | Azimuth Antenna Yoke Assembly | 140504-1 | | | | |
| 1 | | Antenna Drive TG-231/TPN-18 | 170294-1 | | | | | |

4-6. UNPACKING. (CONT)

| CONTAINER NO. | QTY | NAME OR NOMENCLATURE | MFR PART NO. | DIMENSIONS (IN./CM) | | | WEIGHT (LB/KG) |
|------------------|-----|--------------------------------------|-----------------|---------------------|--------------|--------------|-------------------|
| | | | | LENGTH | WIDTH | DEPTH | |
| 2 | 1 | Elevation Antenna Yoke | 102778 | | | | |
| | 1 | Azimuth Drive Reducer | 102626 | | | | |
| 3 | 1 | Receiver- Transmitter Frame No. 3 | 139962 | 51/ 129.54 | 29/ 73.66 | 31/ 78.74 | 559/ 253.78 |
| | 1 | Receiver- Transmitter | 170283-1 | | | | |
| | 1 | Elevation Antenna | 102820 | | | | |
| | 1 | Clinometer | | | | | |
| | 1 | Siting Scope (B4) | 117846 | | | | |
| 4 | 1 | Antenna Pedestal Package No. 4 | 100202 | 68/ 172.72 | 33/ 83.82 | 291 73.66 | 102/ 46.30 |
| 5 and 6 | 2 | Control-Indicator Frame No. 5 (or 6) | 100231 | 27/ 68.58 | 24/ 60/96 | 251 63.5 | 187/ 84.89 |
| | 2 | Control-Indicator | 170278-1 | | | | |
| 7 | 1 | Interconnecting Cable Reel No. 7 | | 34/ 86.36 | 34/ 86.36 | 15/ 38.1 | 225/ 102.15 |
| | 1 | RF Cable Assembly (W3001) | 103173 | | | | |
| | 1 | RF Cable Assembly(W3005) | 103177 | | | | |
| 8 | 1 | Interconnecting Cable Reel No. 8 | | 34/ 86.36 | 34/ 86.36 | 151 38.1 | 249/ 113.04 |
| | 1 | Special Purpose Assembly (W3002) | 103174 | | | | |
| 9 | 1 | Interconnecting Cable Reel No. 9 | | 34/ 86.36 | 34/ 86.36 | 15/ 38.1 | 249/ 113.04 |
| | 1 | Special Purpose Cable Assembly | | | | | |
| 10 | 1 | Interconnecting Cable Reel No. 10 | | 34/ 86.36 | 34/ 86.36 | 15/ 38.1 | 279/ 126.66 |
| | 1 | Power Cable Assembly (W3003) | 103175 | 34/ 86.36 | 34/ 86.36 | 15/ 38.1 | 279/ 126.66 |
| 11 | 1 | Interconnecting Cable Reel No. 11 | | | | | |
| | 1 | Power Cable Assembly (W3004) | 103176 | | | | |
| 12 | 1 | Interconnecting Cable Reel No. 12 | | 34/ 86.36 | 34/ 86.36 | 15/ 38.1 | 145/ 65.83 |
| | 3 | Special Purpose Cable Assembly | | | | | |
| | 1 | Power Cable Assembly (W3007) | 103178 | | | | |

46. UNPACKING. (CONT)

| CONTAINER NO. | QTY | NAME/OR NOMENCLATURE | MFR PART NO. | DIMENSIONS (IN./CM) | | | WEIGHT (LB/KG) |
|---------------|-----|--------------------------------|--------------|---------------------|-------------|---------------|----------------|
| | | | | LENGTH | WIDTH | DEPTH | |
| 12 | 1 | Power Cable Assembly (W9501) | 103167 | | | | |
| | 1 | RF Cable Assembly | 103164 | | | | |
| | | RF Cable Assembly(W9504) | 103165 | | | | |
| | 1 | Special Cable Assembly (W9502) | 103166 | | | | |
| | 1 | Lead Assembly(W3006) | 103199 | | | | |
| 13 | 2 | Power Cable Assembly | 118433 | | | | |
| | 1 | Shipping Drum No. 13 | | 201 50.8 | 20/ 50.8 | 54/ 137.16 | 72/ 32.68 |
| 14 | 1 | Elevation Horn and Polarizer | 102767 | | | | |
| | 1 | Shipping Drum No. 14 | 118464 | 25/ 63.5 | 25/ 63.5 | 36/ 91.44 | 115/ 52.21 |
| | 1 | Flexible Waveguide, Azimuth | 103159 | | | | |
| | | Flexible Waveguide, Azimuth | 102824 | | | | |
| | | Flexible Waveguide, Azimuth | 174600-1 | | | | |
| | | Flexible Waveguide, Elevation | 102823-1 | | | | |
| | | Flexible Waveguide, Elevation | 102823-2 | | | | |
| | 1 | Waveguide | 140769-1 | | | | |
| | 1 | Waveguide | 140768-1 | | | | |
| | 2 | Waveguide | 140787-1 | | | | |
| | 1 | Waveguide | 140771-1 | | | | |
| | 1 | Azimuth Directional Coupler | 174601 | | | | |
| | 1 | Azimuth Horn and Polarizer | 102866 | | | | |
| | 1 | Azimuth Servo Actuator | 100257 | | | | |
| | 1 | Elevation Servo Actuator | 100257 | | | | |
| | 3 | Anchor, 3 In. | G400054-1 | | | | |
| | 1 | Anchor, 6 In. | G400054-2 | | | | |
| | 1 | Strap Ratchet | G470030 | | | | |
| | 2 | Indicator Rain | 112449 | | | | |
| | | Shield and Deflector | 103188 | | | | |

4-6. UNPACKING. (CONT)

WARNING

Shipping containers weigh between 72 and 559 pounds (33 and 254 kg). To prevent personal injury, do not attempt to lift without necessary manpower or lifting device with suitable weight capacity.

CAUTION

Use care when handling all units, especially waveguides and antenna components, to avoid damaging equipment during unpacking.

NOTE

The following unpacking procedures are to be used when radar set is not part of a landing control central system. Refer to TM 11-5895-474-12 addendum when radar set is part of Landing Control Central ANITSQ-71 B.

Items may be packed in a manner different from that shown, depending on the supply channel.

Retain all shipping drums, frames, crates, and associated hardware for use in repacking.

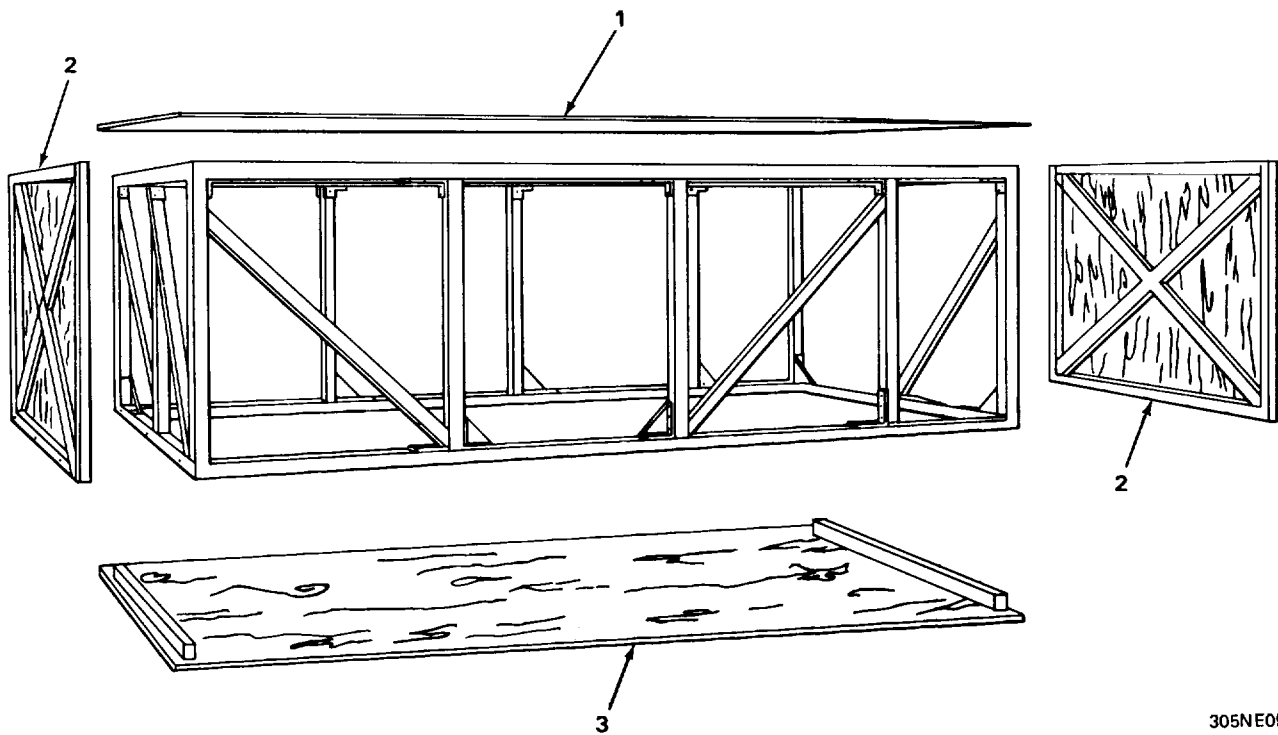

305NE095

1. Locate all shipping crates near radar site.
2. Using pry bar, pry off top (1) and sides (2) of crate.
3. Using suitable lifting device, lift unit off bottom pallet (3).

44. UNPACKING. (CONT)

SHIPPING FRAME NO. 1

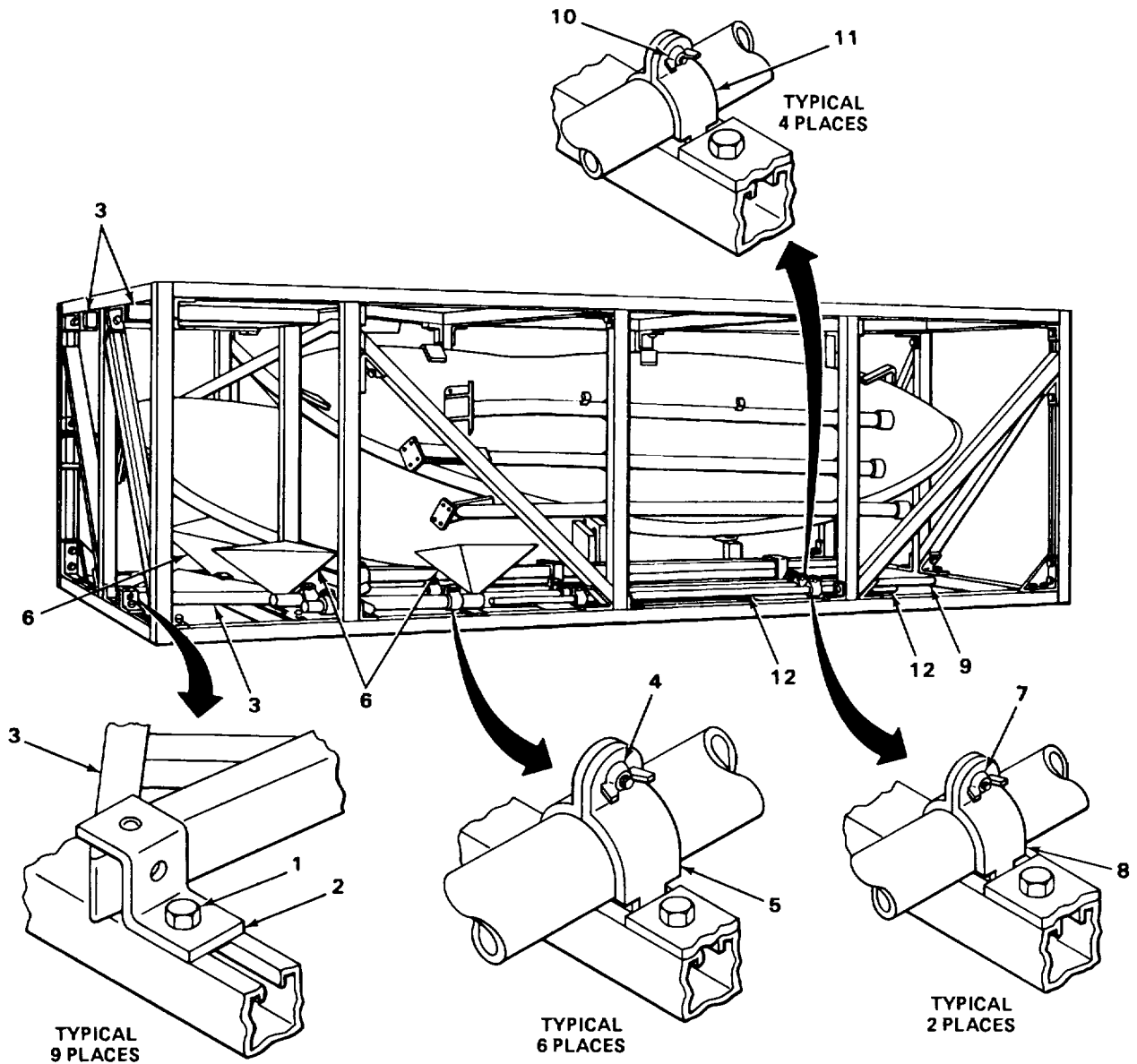

305NE182

1. Loosen nine screws (1) that secure nine fittings (2).
2. Remove three polarizer assemblies (3).
3. Loosen six wingnuts (4) in six clamps (5) that secure three reflector assemblies (6).
4. Remove three reflector assemblies (6).
5. Loosen two wingnuts (7) in two clamps (8) and remove ground rod (9).
6. Loosen four wingnuts (10) in four clamps (11) and remove two driving rods (12).

4-6. UNPACKING. (CONT)

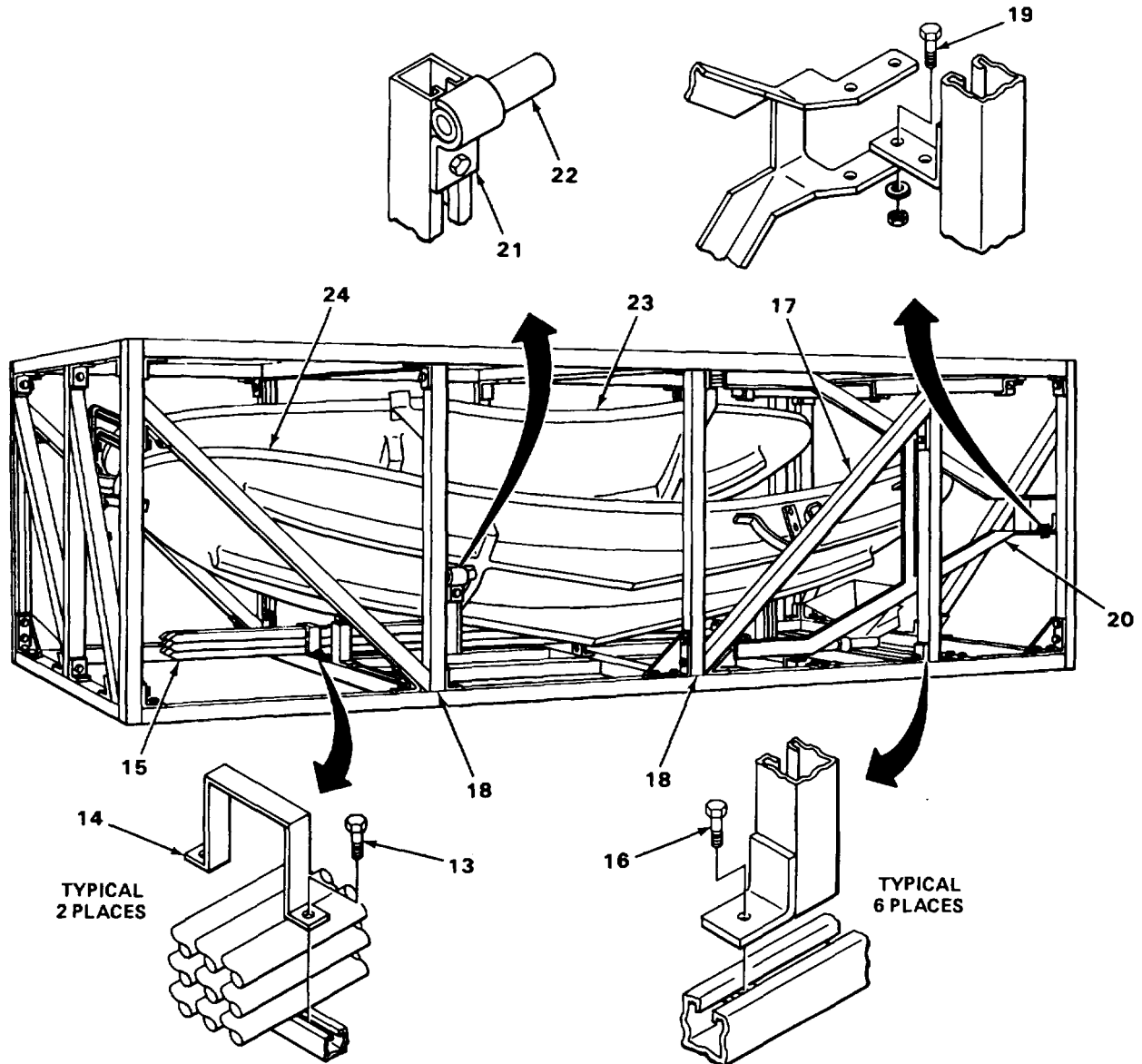

305NE183

7. Loosen four screws (13) in two clamps (14) and remove nine target posts (15).
8. Remove six screws (16) that secure one brace (17) and two trusses (18).
9. Remove brace (17) and both trusses (18).
10. Remove screw (19) that secures azimuth horn and polarizer (20) and remove azimuth horn and
11. Loosen two clamps (21) and remove two bushings (22) from pivot bore in elevation antenna.

WARNING

Azimuth and elevation antennas weigh 155 pounds (70 kg) and 227 pounds (103 kg), respectively. To prevent personal injury, do not attempt to lift without necessary manpower or lifting device with suitable weight capacity.

12. Remove azimuth antenna reflector (23) by sliding out of rear of shipping frame.
13. Remove elevation antenna reflector (24) by sliding out of rear of shipping frame.

46. UNPACKING. (CONT)

SHIPPING FRAME NO. 2

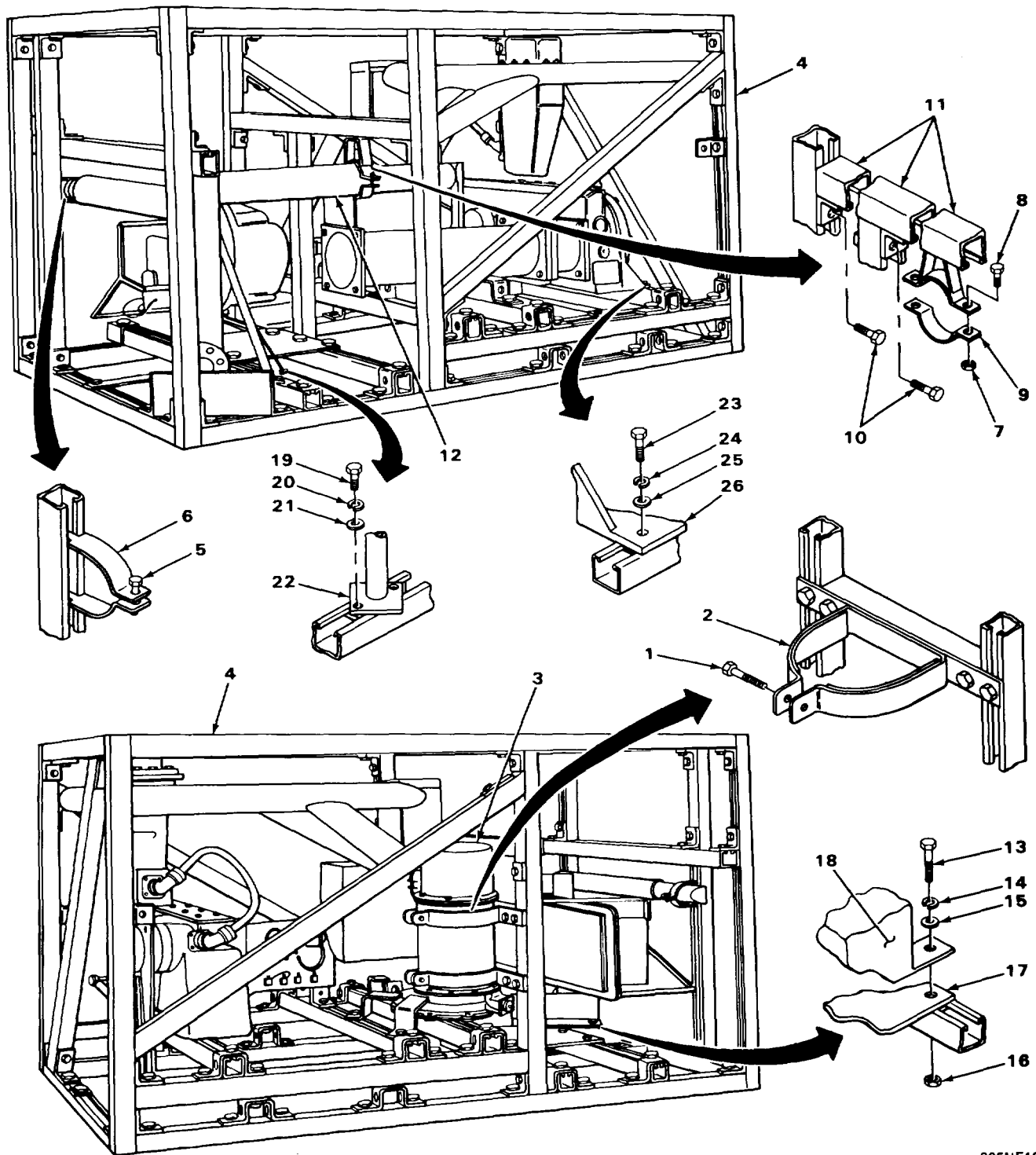

305NE184

44. UNPACKING. (CONT)

1. Loosen two bolts (1) in two clamps (2).
2. Remove azimuth drive reducer (3) from shipping frame (4).
3. Loosen one bolt (5) in clamp (6).
4. Remove two nuts (7) and bolts (8) in clamp (9) and remove bottom of clamp.
5. Remove two bolts (10) securing truss (11) and remove truss.
6. Remove elevation yoke assembly (12) from shipping frame (4).
7. Using two nuts (7) and bolts (8), reconnect bottom of clamp (9) to truss (11).
8. Remove four screws (13), lockwashers (14), flat washers (15), and nuts (16) from mounting plate (17).

WARNING

Azimuth and elevation antenna drives weigh 225 pounds (102 kg) and 205 pounds (93 kg), respectively. To prevent personal injury, do not attempt to lift without necessary manpower or lifting device with suitable weight capacity.

9. Lift azimuth antenna drive with azimuth yoke assembly attached (18) from shipping frame (4).
10. Remove four bolts (19), lockwashers (20), and flat washers (21) and remove elevation actuator support arm (22).
11. Remove three bolts (23), lockwashers (24), and flat washers (25) securing elevation antenna
12. Lift elevation antenna drive (26) from shipping frame (4).

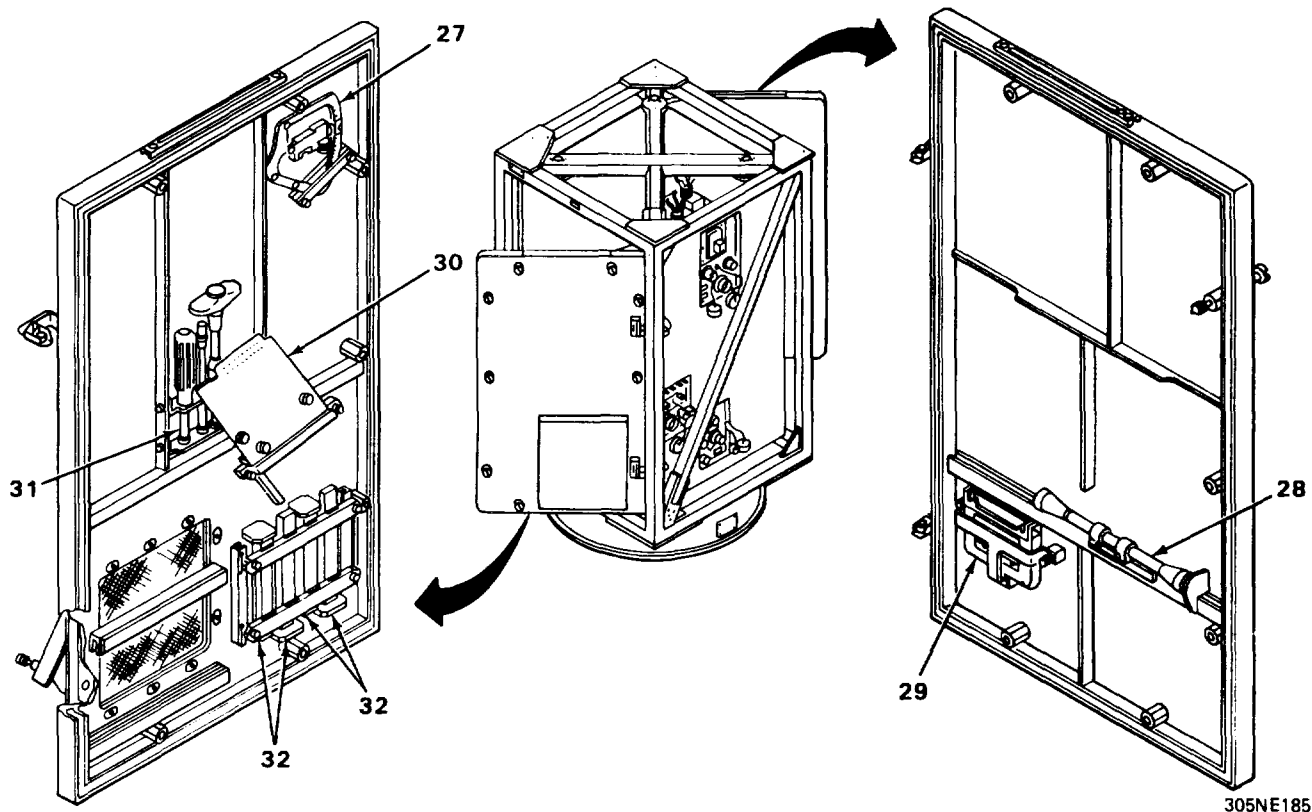

13. Open receiver and transmitter doors.
14. Observe that clinometer (27), sighting scope (28), card extractor (29), test card adapter (30), wrench set (31), and two sets of preselector filters (32) are supplied.

4-6. UNPACKING. (CONT)

DRUM NO. 5

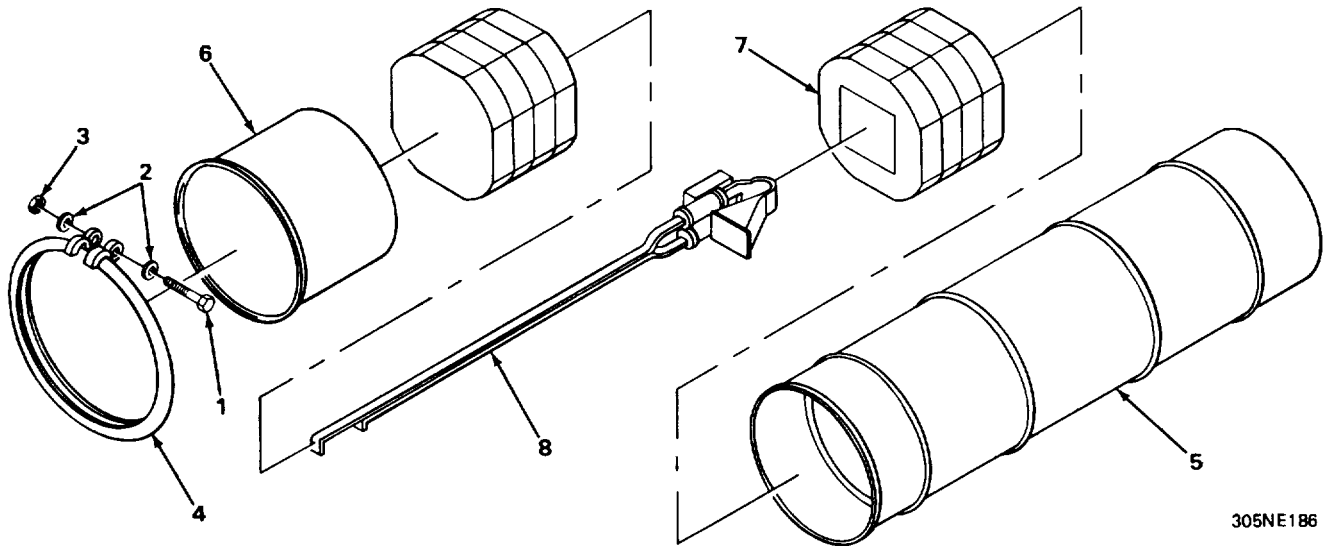

1. Remove one screw (1), two flat washers (2), and one nut (3) from securing ring (4).
2. Remove securing ring (4) from drum (5).
3. Remove lid (6) and packing foam (7) from drum (5).
4. Lift elevation horn and polarizer (8) out of drum (5).

DRUM NO. 6

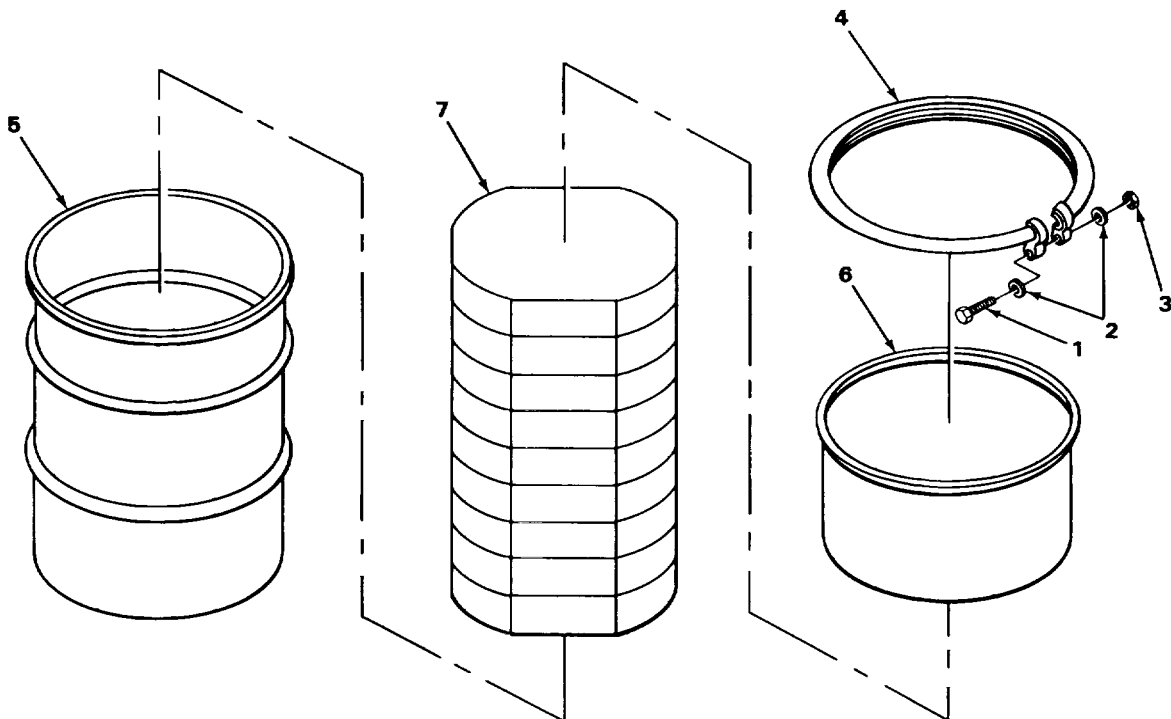

4-6. UNPACKING. (CONT)

1. Remove one screw (1), two flat washers (2), and one nut (3) from securing ring (4).
2. Remove securing ring (4) from drum (5).
3. Remove lid (6) from drum (5).
4. Remove nine shipping pads (7), containing waveguides and hardware, from drum (5).

CHECKING UNPACKED EQUIPMENT

Inspect all equipment for possible damage incurred during shipment. If any equipment has been damaged, report the damage on DD Form 6 (Packing Improvement Report).

Check the equipment against the packing slip to ensure shipment is complete. Report any discrepancies in accordance with Maintenance Forms, Records, and Reports (para 1-3). The equipment should be placed in operation even though a minor assembly or part, that does not affect proper functioning, is missing.

Check that all applicable MWOs listed in DA PAM 310-1 have been applied to the equipment.

4-7. RADAR SET ASSEMBLY AND INSTALLATION INSTRUCTIONS.**NOTE**

Refer to TM 11-5895-474-12 addendum for assembly and installation instructions when radar set is part of Landing Control Central AN/TSQ-71 B.

Two persons are required to assemble and install radar set. Complete installation for a single runway, including equipment siting, assembly, radar target simulator siting, and preliminary servicing and adjustment, can be accomplished in 4 hours (8.5 task hours). Electronic Equipment Tool Kit TK-101/G is used for all assembly and installation procedures. A lifting device, with suitable weight capacity, is required to lift and position components of radar set. The weight of the individual components is given at the beginning of each procedure.

4-8. ANTENNA PEDESTAL ASSEMBLY.

MATERIALS/PARTS: Cloth sack marked ANTENNA PEDESTAL HARDWARE

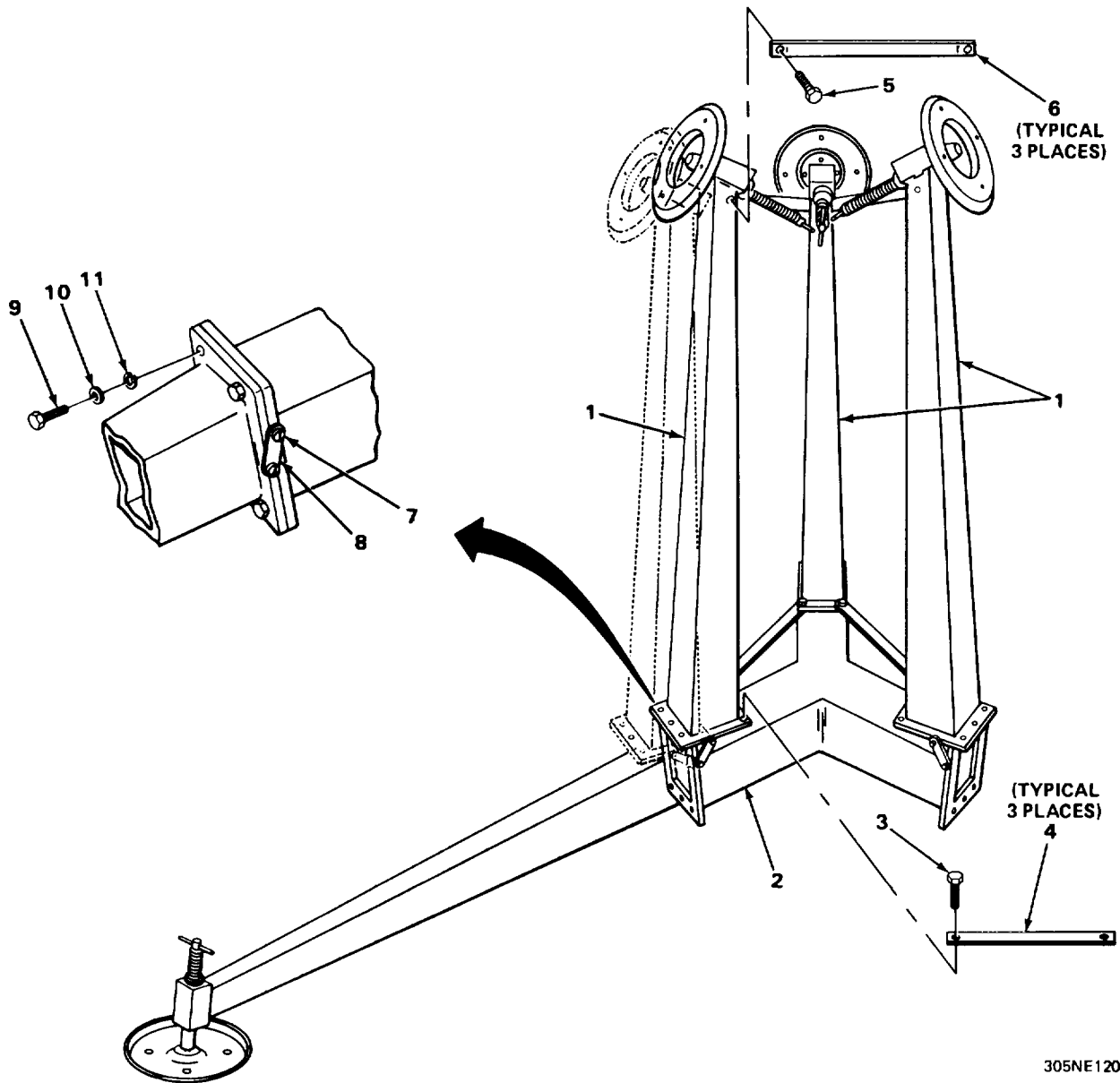

305NE120

WARNING

Antenna pedestal weighs 102 pounds (46 kg). To prevent personal injury, do not attempt to lift without necessary manpower or lifting device with suitable weight capacity.

1. Position antenna pedestal with leg assemblies (1) pointing upward, on a support that is slightly smaller than center section (2).

4-8. ANTENNA PEDESTAL ASSEMBLY. (CONT)

2. Remove two retaining bolts (3) from each of three bottom retaining straps (4) and two retaining bolts (5) from each of three top retaining straps (6) and remove straps.
3. Unbolt three bottom (4) and three top retaining straps (6) securing three leg assemblies (1).
4. On each leg assembly (1) loosen, but do not remove, four screws (7) securing two retaining hinges (8).
5. Lower each leg assembly (1) by sliding it away from the center section (2) and then swinging it down.
6. Using five bolts (9), flat washers (10), and lockwashers (11), secure each leg assembly (1) to center section (2).
7. On each leg assembly (1), tighten four screws (7) loosened in step 4, in two retaining hinges (8).

4-9. AZIMUTH ANTENNA DRIVE ASSEMBLY.

MATERIALS/PARTS: Cloth sack marked AZIMUTH ANTENNA DRIVE HARDWARE

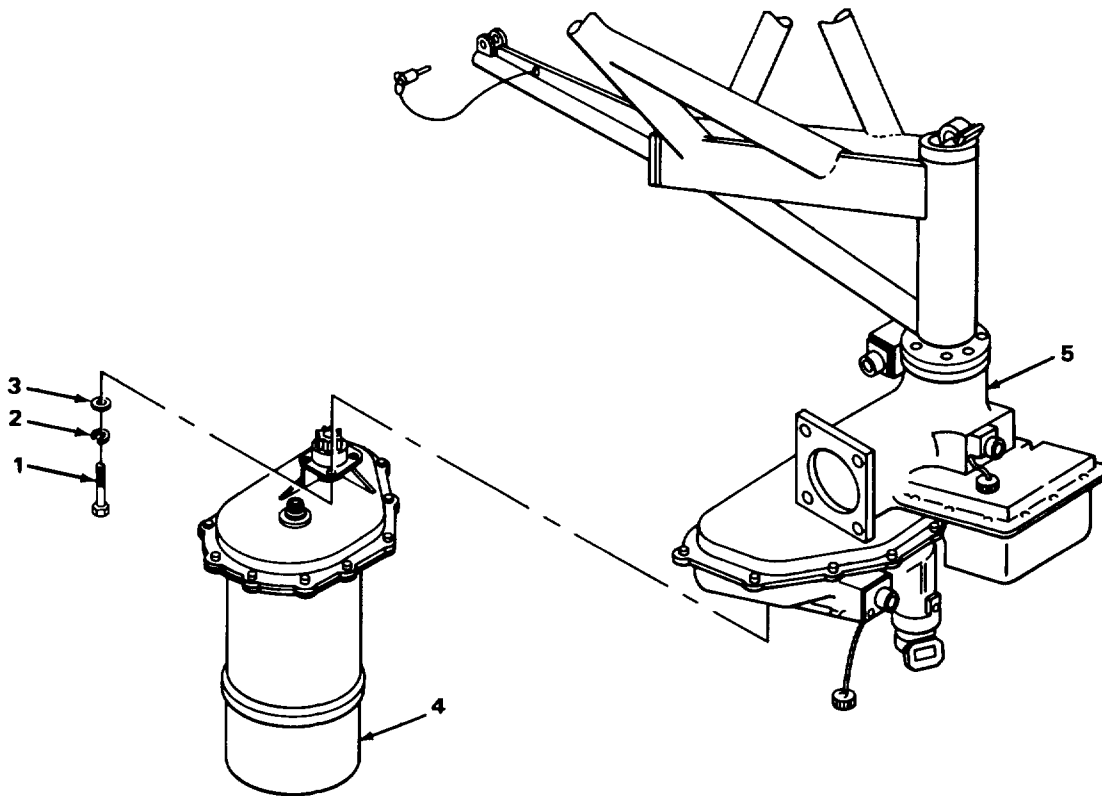

305NE100

CAUTION

To prevent damage to rotary joint waveguide, turn azimuth antenna yoke assembly so curved portion of rotary joint waveguide is facing away from azimuth antenna drive.

Using four bolts (1), lockwashers (2), and flat washers (3), secure azimuth antenna drive reducer (4) to azimuth antenna drive (5).

4-10. AZIMUTH ANTENNA ASSEMBLY.

MATERIALS/PARTS: Cloth sack marked AZIMUTH ANTENNA HARDWARE

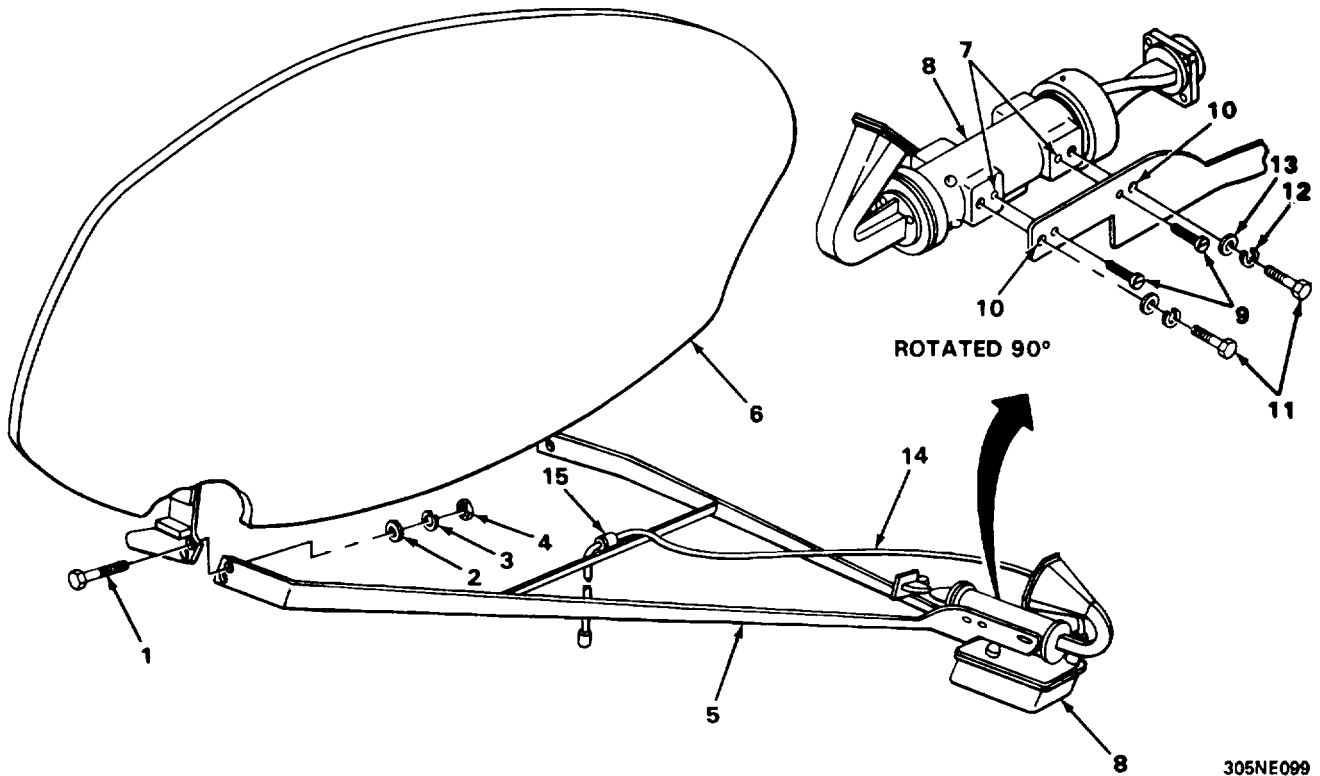

305NE099

WARNING

Azimuth antenna weighs 155 pounds (70 kg). To prevent personal injury, do not attempt to lift without necessary manpower or lifting device with suitable weight capacity.

1. Using six shoulder bolts (1), flat washers (2), lockwashers (3), and nuts (4), secure azimuth horn and polarizer support (5) on azimuth antenna (6).

4-10. AZIMUTH ANTENNA ASSEMBLY. (CONT)**CAUTION**

Incorrect alignment of azimuth horn and polarizer with azimuth horn and polarizer support can cause improper focusing of high-frequency beams on antenna and can damage azimuth horn and polarizer. Review and become familiar with steps 2 through 9 before assembling azimuth horn and polarizer on azimuth horn and polarizer support.

2. Observe four alignment dimples (7) on machined surface of azimuth horn and polarizer (8).
3. Remove two alignment pins (9) from one side of azimuth horn and polarizer (8).
4. On opposite side of azimuth horn and polarizer (8), loosen two alignment pins (9) as far as possible without removing them.
5. Assemble azimuth horn and polarizer (8) on azimuth horn and polarizer support (5) and hand tighten alignment pins (9) loosened in step 4.
6. Adjust azimuth horn and polarizer (8) so alignment holes (10) and dimples (7) are in alignment and loosely install four hex screws (11), lockwashers (12), and flat washers (13).
7. Ensure correct positioning of azimuth horn and polarizer (8) by sighting through two open alignment screw holes on azimuth horn and polarizer support (5) and verifying they are aligned with their respective alignment holes (10) on the azimuth horn and polarizer (8).
8. Carefully tighten four hex screws (11), making sure depth of alignment pins (9) does not prevent flush mounting of azimuth horn and polarizer support (5) with machined surfaces of azimuth horn and polarizer (8).
9. Install and hand tighten two alignment pins (9) removed in step 3.

CAUTION

Do not put excessive weight on azimuth horn and polarizer assembly. Damage to one or both could result.

10. Attach cable (14) to azimuth horn and polarizer support (5) with clamp (15).

4-11. ELEVATION ANTENNA ASSEMBLY.

TOOLS: 1 1/2 -inch open-end wrench

MATERIALS/PARTS: Cloth sack marked ELEVATION ANTENNA HARDWARE

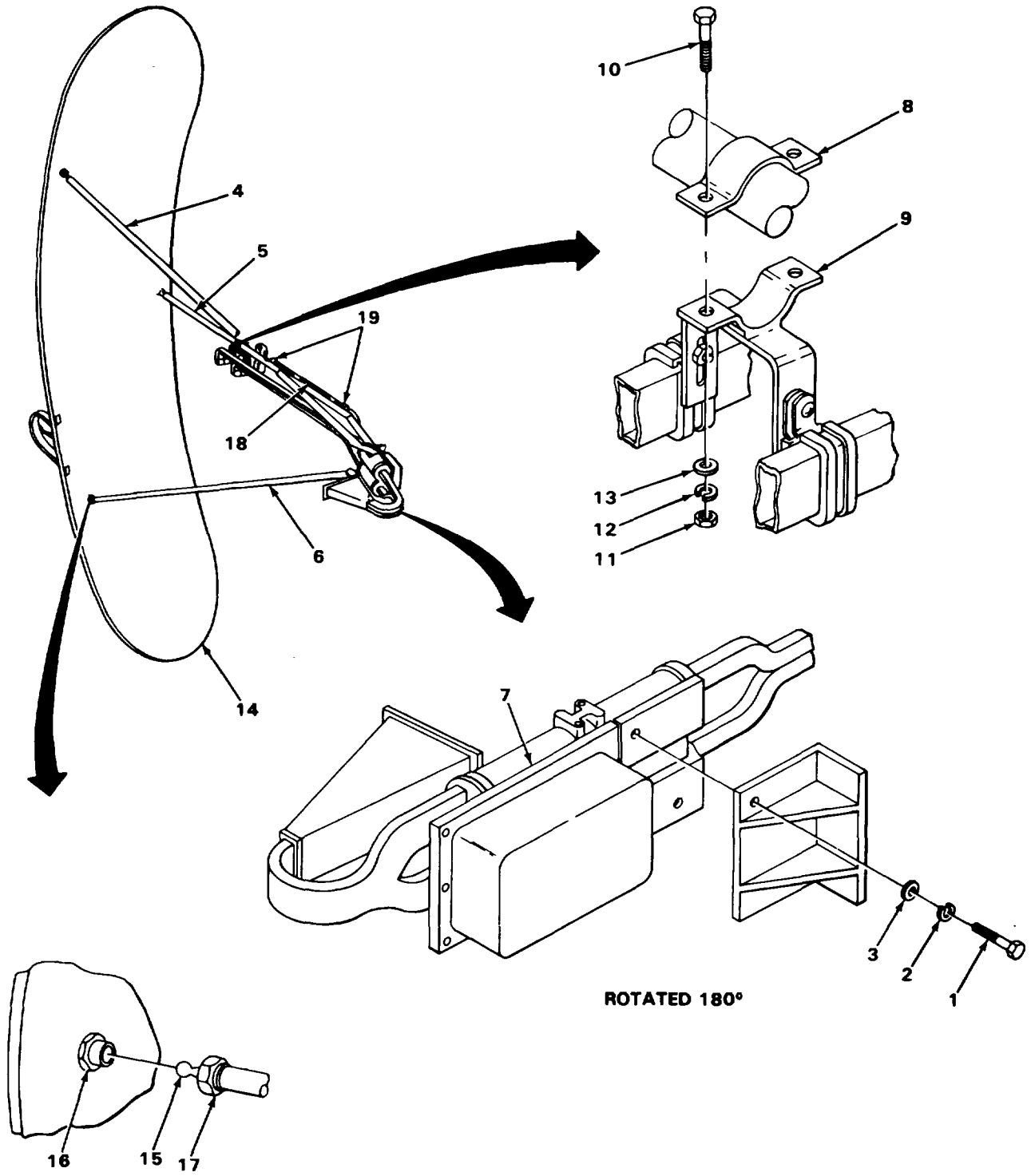

305NE121

4-11. ELEVATION ANTENNA ASSEMBLY. (CONT)**WARNING**

Elevation antenna weighs 227 pounds (103 kg). To prevent personal injury, do not attempt to lift without necessary manpower or lifting device with suitable weight capacity.

CAUTION

Take care not to disturb clamp when handling elevation horn and polarizer. If clamp is disturbed, feed horn will be moved with respect to antenna. This will result in improper focusing of high-frequency beams on antenna.

1. Using six screws (1), lockwashers (2), and flat washers (3), assemble three elevation horn and polarizer support arms (4, 5, and 6) on elevation horn and polarizer (7).
2. Temporarily remove clamp (8) from mounting bracket (9) on elevation horn and polarizer (7) by removing two screws (10), hex nuts (11), lockwashers (12), and flat washers (13).
3. Position support arm (5) in recess of mounting bracket (9) and replace clamp (8) removed in Step 2.
4. Attach each support arm (4, 5, and 6) to elevation antenna (14) by inserting alignment ball (15) into plughole (16) and tightening coupling nut (17) with 1 1/2-inch open-end wrench.
5. Using two clamps (18), attach cable (19) to support arm (5).

4-12. ANTENNA PEDESTAL INSTALLATION.

TOOLS: Sledgehammer

MATERIALS/PARTS: 6-inch anchor
 3-inch anchor (three required)
 3-foot driving rod
 4-foot driving rod
 Strap ratchet

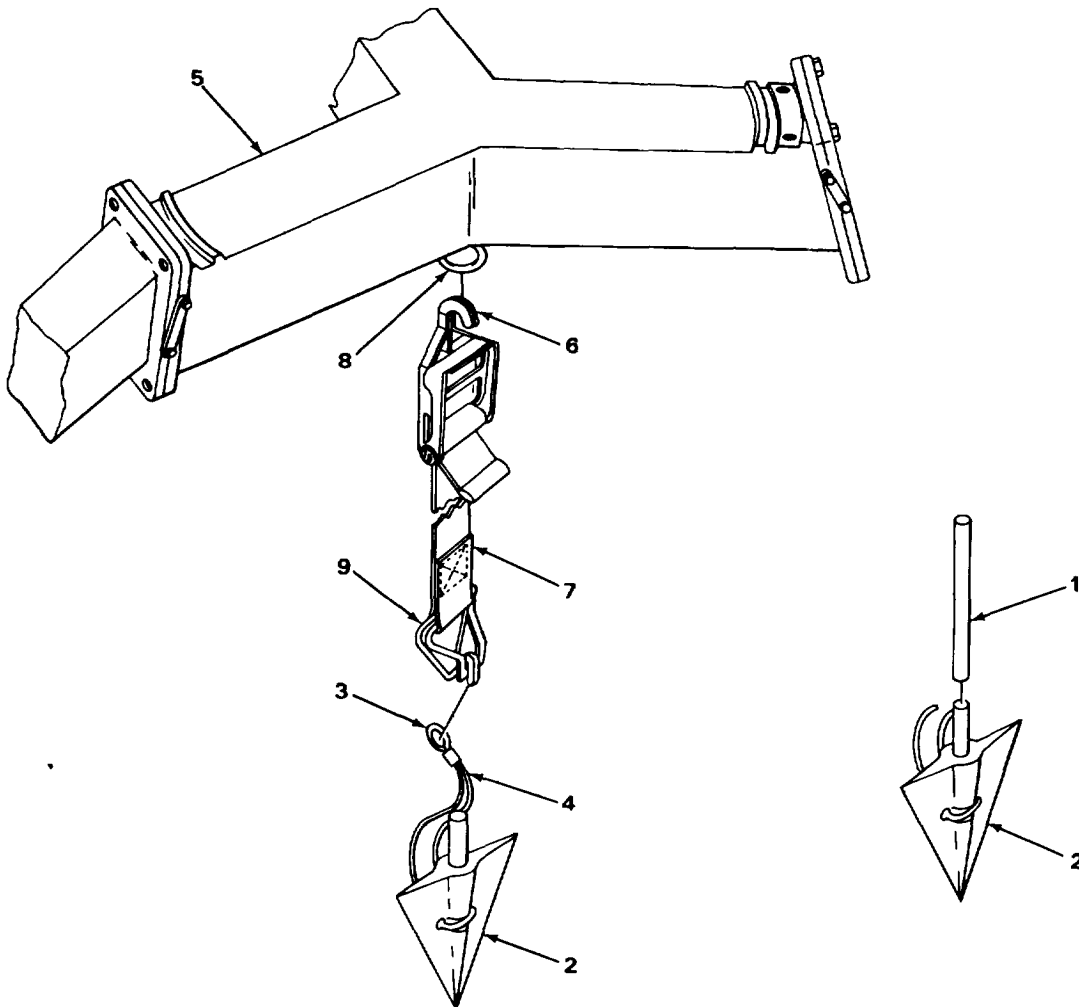

305NE132

WARNING

Antenna pedestal weighs 102 pounds (46 kg). To prevent personal injury, do not attempt to lift without necessary manpower or lifting device with suitable weight capacity.

4-12. ANTENNA PEDESTAL INSTALLATION. (CONT)

1. Attach 4-foot driving rod (1) to 6-inch anchor (2).
2. Using sledgehammer, drive 6-inch anchor (2) into ground at center of antenna pedestal location until loop (3) in anchor cable (4) is at ground level.
3. Remove driving rod from 6-inch anchor (2) and pull anchor cable (4) upward to partially set anchor.
4. Position antenna pedestal (5) over anchor (2).
5. Attach hook (6) on strap ratchet (7) to eyebolt (8) on antenna pedestal.
6. Place loop (3) on end of anchor cable (4) into clasp (9) on other end of strap ratchet (7).
7. Tighten strap ratchet (7).

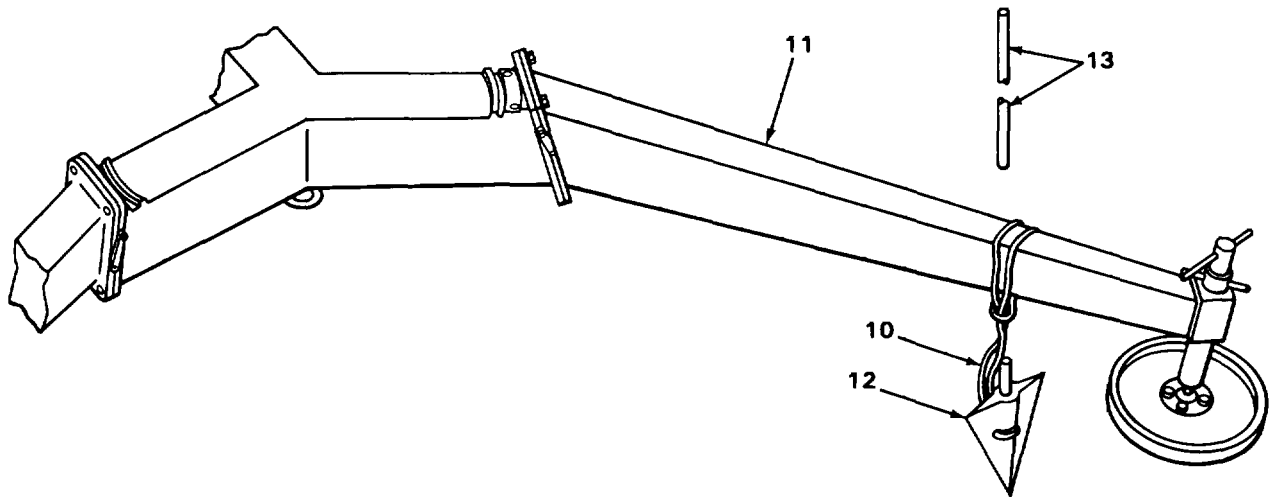

305NE132

8. Loop anchor cable (10) around pedestal leg (11) and slide 3-inch anchor (12) through loop in cable.
9. Attach 3-foot driving rod (13) to anchor and drive anchor (12) 2 feet into ground next to pedestal leg (11).
10. Remove driving rod (13) and pull anchor cable (10) upward to set anchor (12).
11. Repeat steps 8, 9, and 10 for each pedestal leg.

4-13. RECEIVER-TRANSMITTER GROUP INSTALLATION.

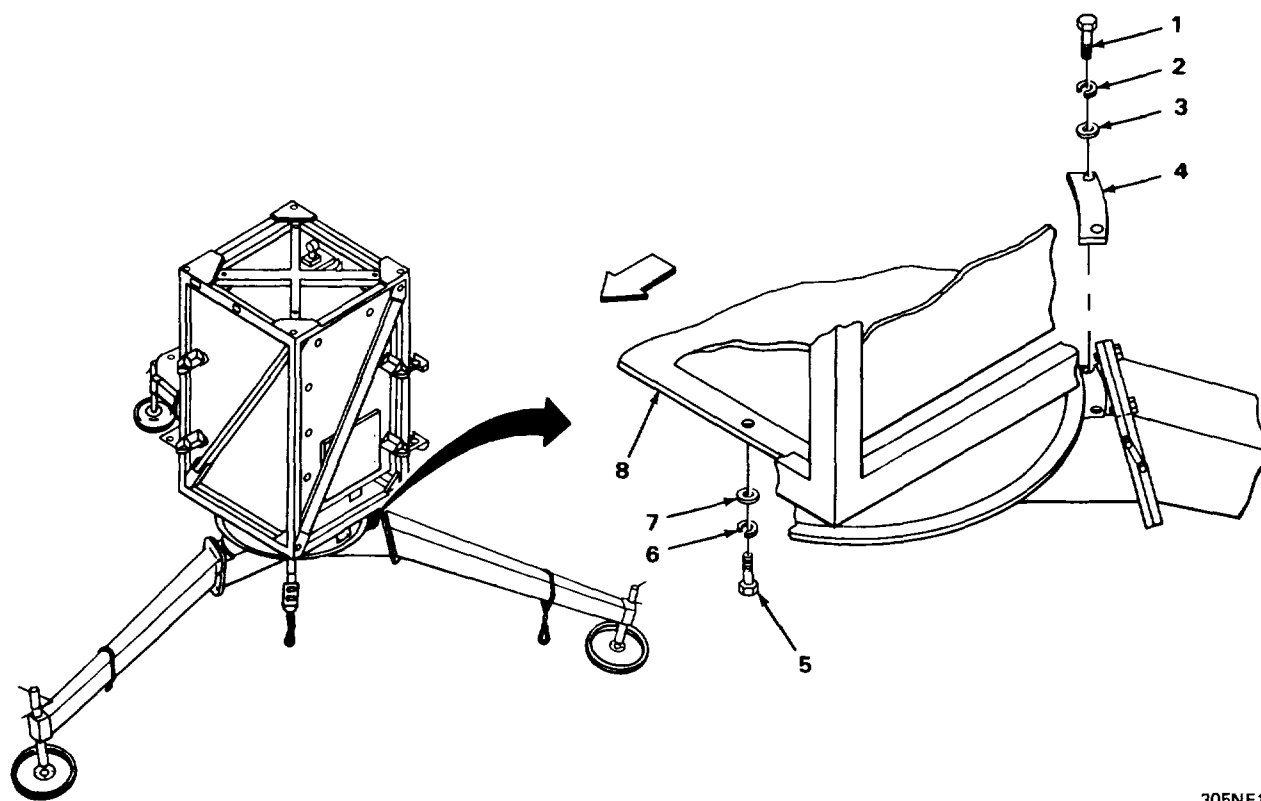

305NE133

WARNING

Receiver-transmitter group weighs 580 pounds (263 kg). To prevent personal injury, do not attempt to lift without necessary manpower or lifting device with suitable weight capacity.

1. On antenna pedestal, temporarily remove six screws (1), lockwashers (2), and flat washers (3) securing three strap clamps (4).
2. Position receiver-transmitter group on center section of antenna pedestal and secure with six screws (1), lockwashers (2), flat washers (3), and three strap clamps (4) removed in step 1.
3. Remove six fasteners (5), lockwashers (6), and flat washers (7) securing red vent cover (8) to bottom of receiver-transmitter.
4. Remove vent cover (8) by sliding out through space between receiver-transmitter and receiver-transmitter frame.

4-14. ELEVATION ANTENNA DRIVE INSTALLATION.

MATERIALS/PARTS; Cloth sack marked ELEVATION ANTENNA DRIVE HARDWARE

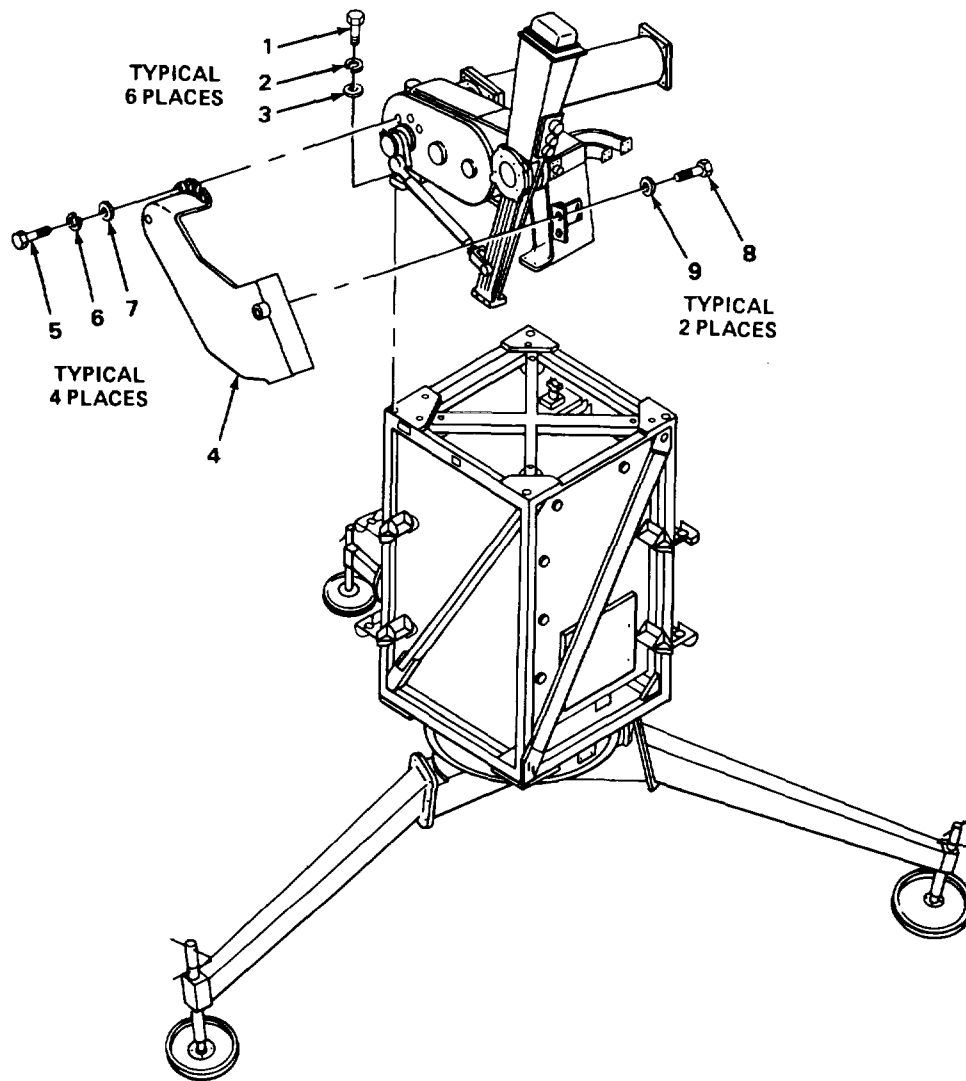

305NE134

WARNING

Elevation antenna drive weighs 205 pounds (93 kg). To prevent personal injury, do not attempt to lift without necessary manpower or lifting device with suitable weight capacity.

1. Position elevation antenna drive on top of receiver-transmitter and, using six screws (1), lock-washers (2), and flat washers (3), secure.
2. Place elevation safety shield (4) on side of elevation antenna drive and, using four screws (5), lockwashers (6), and flat washers (7), secure top end. Using two screws (8) and flat washers (9), secure bottom end.

4-15. AZIMUTH ANTENNA DRIVE AND YOKE ASSEMBLY INSTALLATION.

MATERIALS/PARTS: Cloth sacks marked AZIMUTH ANTENNA DRIVE HARDWARE and AZIMUTH ANTENNA YOKE ASSEMBLY HARDWARE

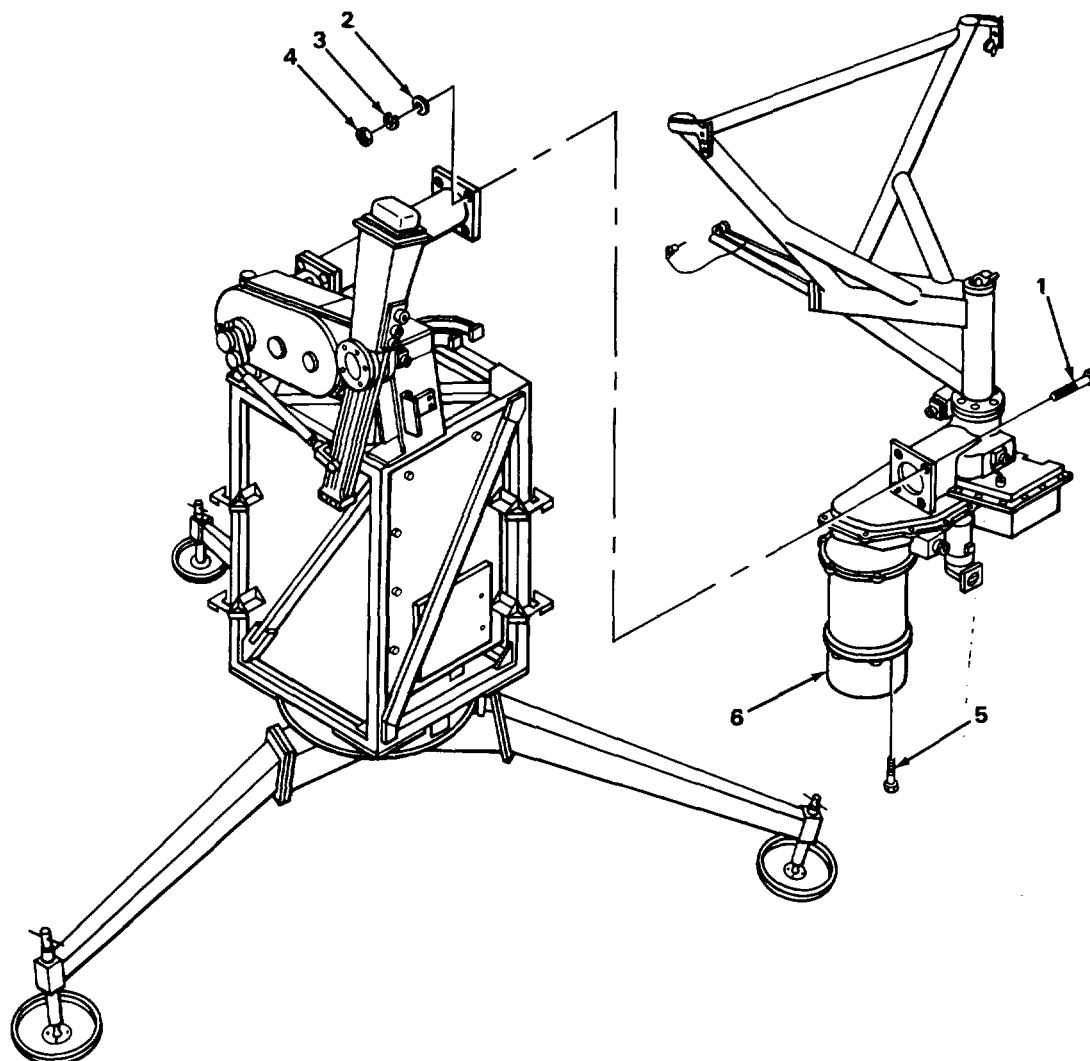

305NE135

WARNING

Azimuth antenna drive and yoke assembly weighs 225 pounds (102 kg). To prevent personal injury, do not attempt to lift without necessary manpower or lifting device with suitable weight capacity.

1. Position azimuth antenna drive, with yoke assembly pointing upward, on elevation antenna drive, and secure using four screws (1), flat washers (2), lockwashers (3), and nuts (4).
2. Remove six fasteners (5) securing red protective cover (6) from azimuth drive motor. Store protective cover and hardware for use in repacking.

4-16. AZIMUTH ANTENNA INSTALLATION.

MATERIALS/PARTS: Cloth sack marked AZIMUTH ANTENNA HARDWARE

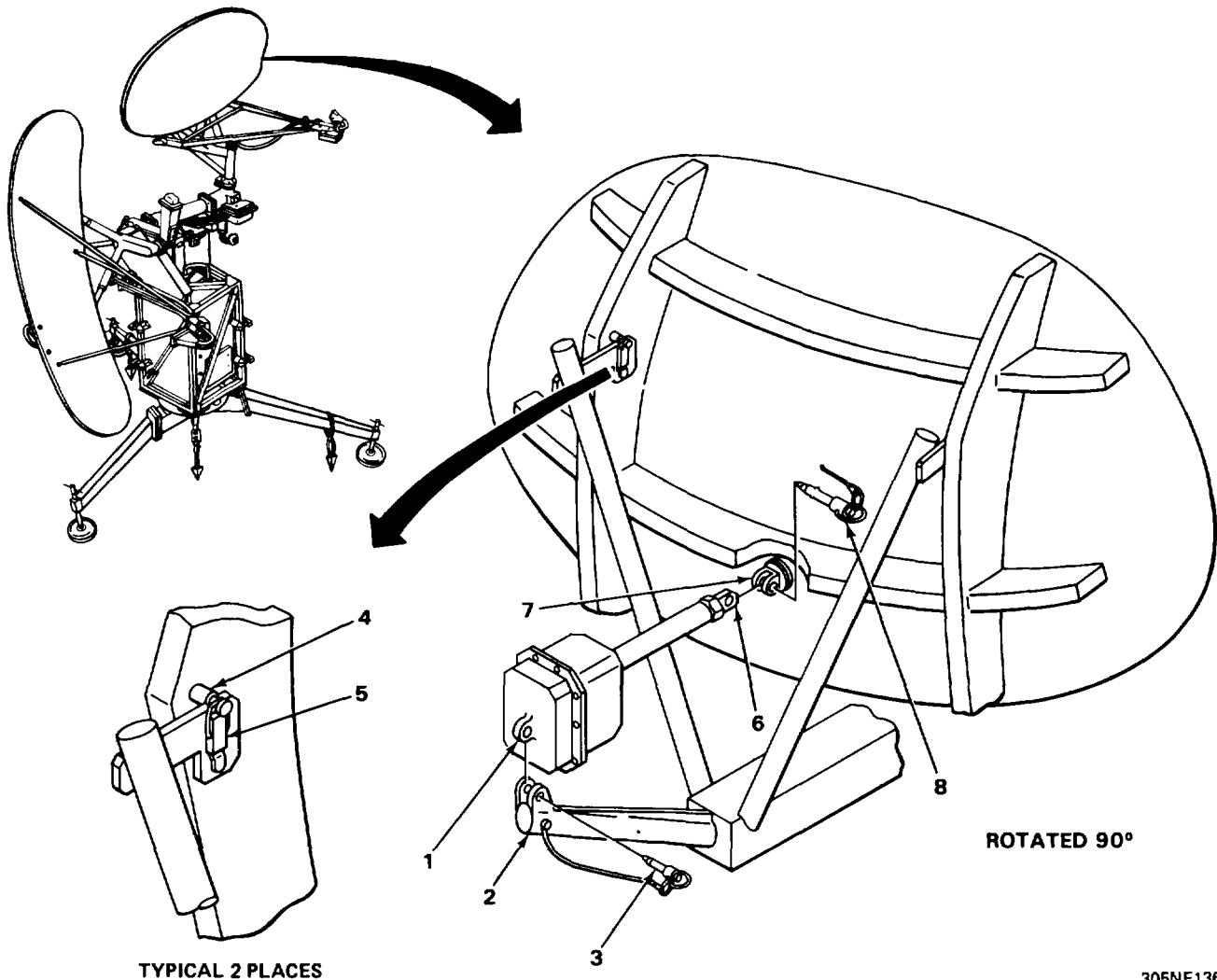

WARNING

Azimuth antenna weighs 155 pounds (70 kg). To prevent personal injury, do not attempt to lift without necessary manpower or lifting device with suitable weight capacity.

1. Attach servo end (1) of azimuth servo actuator to center arm (2) of azimuth antenna yoke assembly and secure with locking pin (3).
2. Lift azimuth antenna and mount on azimuth antenna yoke assembly by inserting two mounting pins (4) on back of antenna in notch on azimuth antenna yoke assembly.
3. Secure both antenna latches (5), making sure loop of latch is in groove on pin.
4. Slide end of azimuth servo actuator shaft (6) into servo mount (7) on back of azimuth antenna.
5. Secure with locking pin (8).

4-17. ELEVATION YOKE ASSEMBLY INSTALLATION.

MATERIALS/PARTS: Cloth sack marked ELEVATION YOKE ASSEMBLY HARDWARE

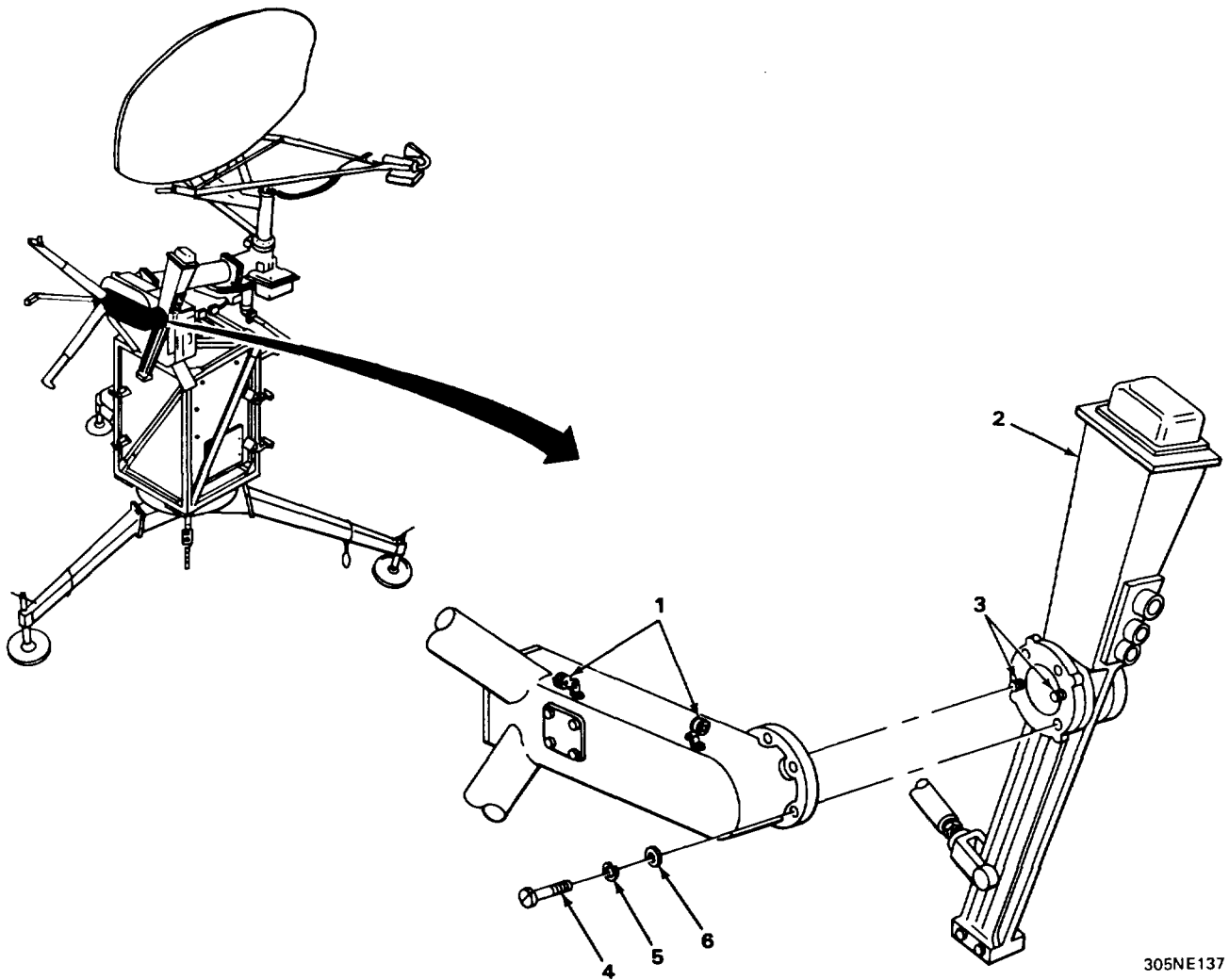

1. Position elevation yoke, with loop clamps (1) pointing upward, against elevation antenna drive (2) and aline two guide pins (3) with alinement holes on back of yoke assembly.
2. Using four screws (4), lockwashers (5), and flat washers (6), secure elevation yoke to elevation antenna drive (2).

4-18. ELEVATION ANTENNA INSTALLATION.

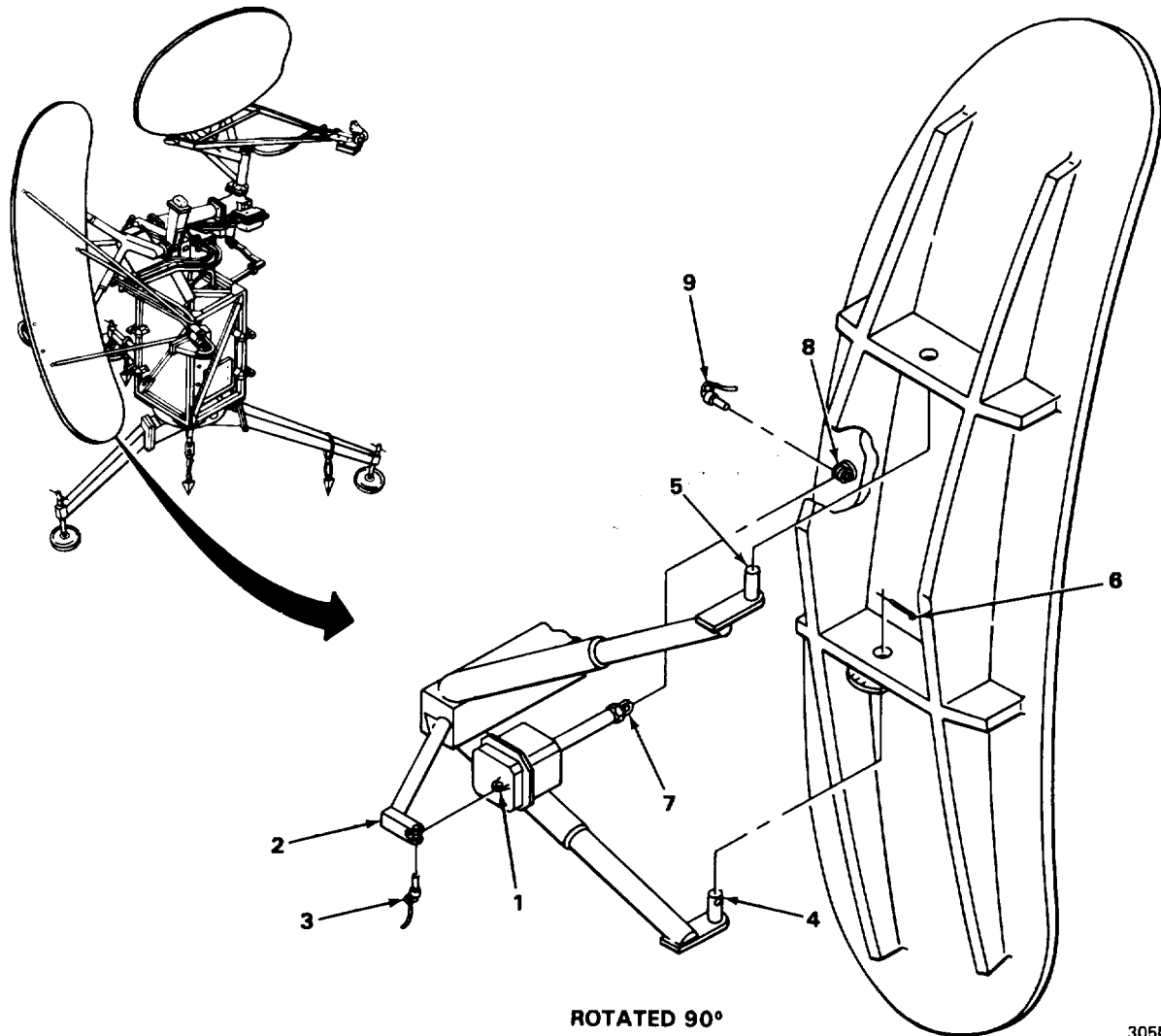

305NE138

WARNING

Elevation antenna weighs 227 pounds (103 kg). To prevent personal injury, do not attempt to lift without necessary manpower or lifting device with suitable weight capacity.

1. Attach servo end (1) of elevation servo actuator to center arm (2) of elevation yoke assembly and secure using pin (3).
2. Mount elevation antenna on elevation yoke assembly support pins (4 and 5). Insert clip (6) into lower support pin (4) to secure elevation antenna.
3. Slide end of elevation servo actuator shaft (7) into mounting tabs (8) on back of elevation antenna and secure using pin (9).

4-19. WAVEGUIDES INSTALLATION.

CAUTION

When assembling and installing waveguides, position them as shown in accompanying illustrations. Take care not to dent or otherwise damage waveguides while handling. Be sure that preformed packings are in place before making waveguide connection.

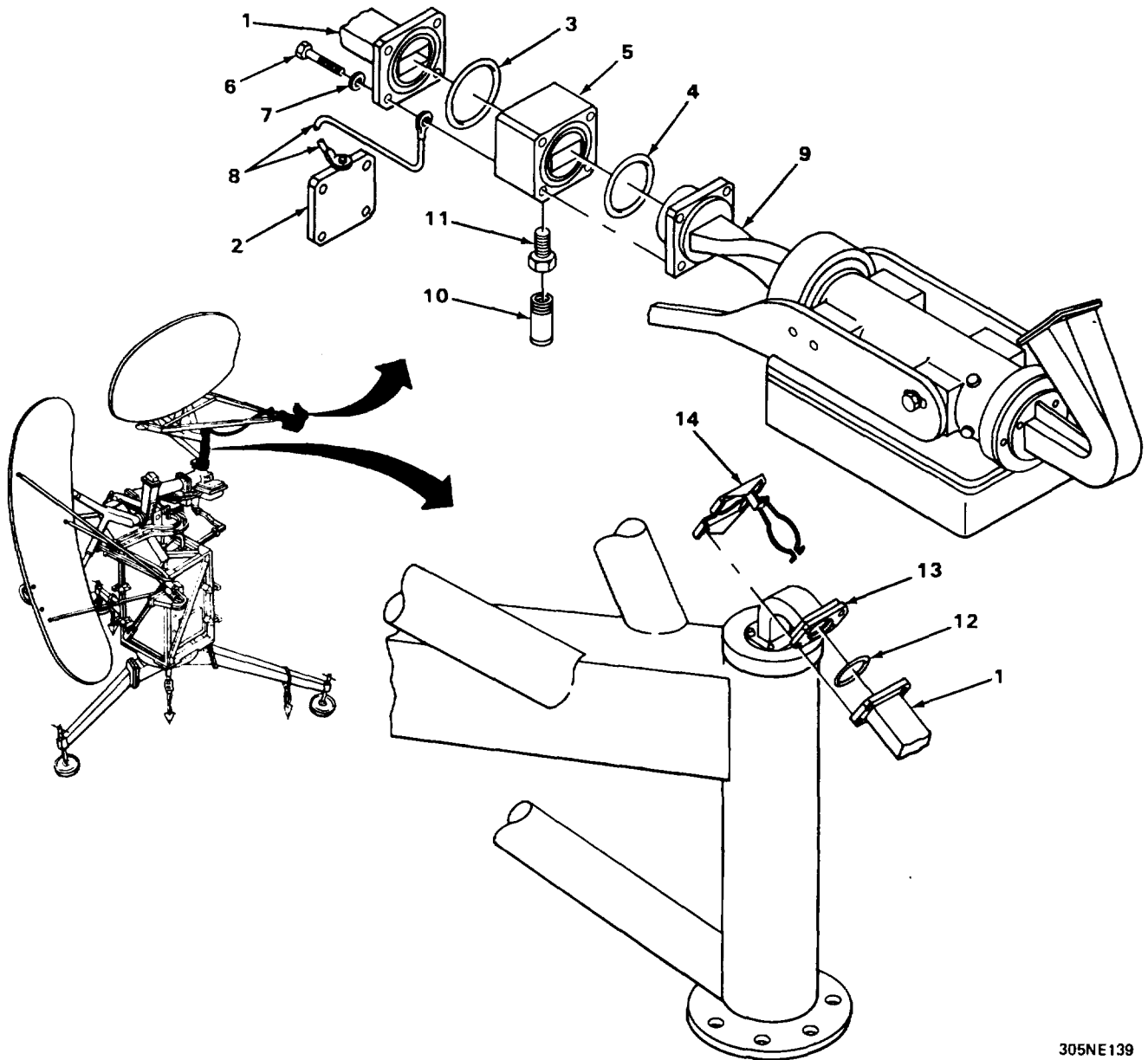

305NE139

4-19. WAVEGUIDES INSTALLATION. (CONT)

1. Locate flexible waveguide PN 102824 (1) on shipping pad.
2. Remove four screws securing waveguide cover (2) to flexible waveguide (1). Retain hardware for use in repacking.
3. Insert preformed packings (3 and 4) into recesses in waveguide adapter (5). Using four screws (6) and lockwashers (7), attach flexible waveguide (1) and waveguide adapter (5), along with wire rope assembly (8) to azimuth horn and polarizer (9).
4. Insert dehydrator cartridge (10) into dehydrator cartridge adapter (11). Install this assembly into bottom of waveguide adapter.

CAUTION

When performing step 5, position flexible waveguide so that curved portion will clear elevation antenna drive when azimuth antenna rotates.

5. Insert preformed packing (12) into recess in flange on free end of flexible waveguide (1). Install flexible waveguide on azimuth antenna yoke waveguide flange (13) and, using waveguide coupling (14), secure.

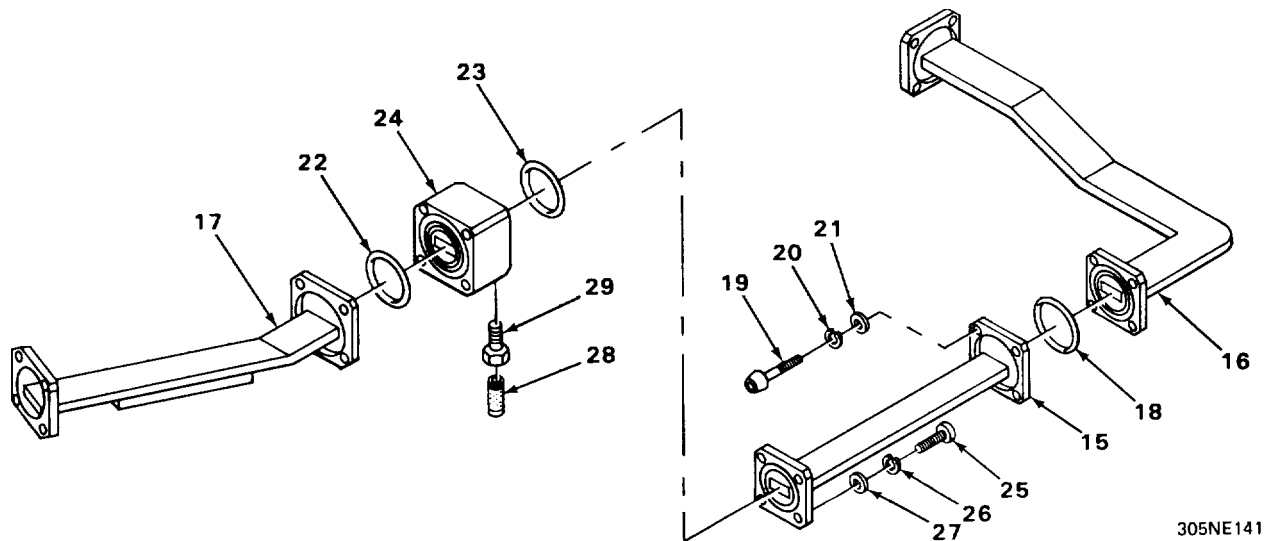

6. Locate flexible waveguide PN 174600-1 (15), rigid waveguide assembly PN 140771-1 (16), and directional coupler PN 174601-1 (17) on shipping pads.
7. Attach flexible waveguide (15) to rigid waveguide assembly (16) by placing preformed packing (18) into recess in flange and securing with four screws (19), lockwashers (20), and flat
8. Insert preformed packings (22 and 23) into recesses in flanges of waveguide adapter (24). Using four screws (25), lockwashers (26), and flat washers (27), secure adapter between flexible waveguide (15) and directional coupler (17).
9. Insert dehydrator cartridge (28) into dehydrator cartridge adapter (29). Install this assembly into bottom of waveguide adapter (24).

4-19. WAVEGUIDES INSTALLATION. (CONT)

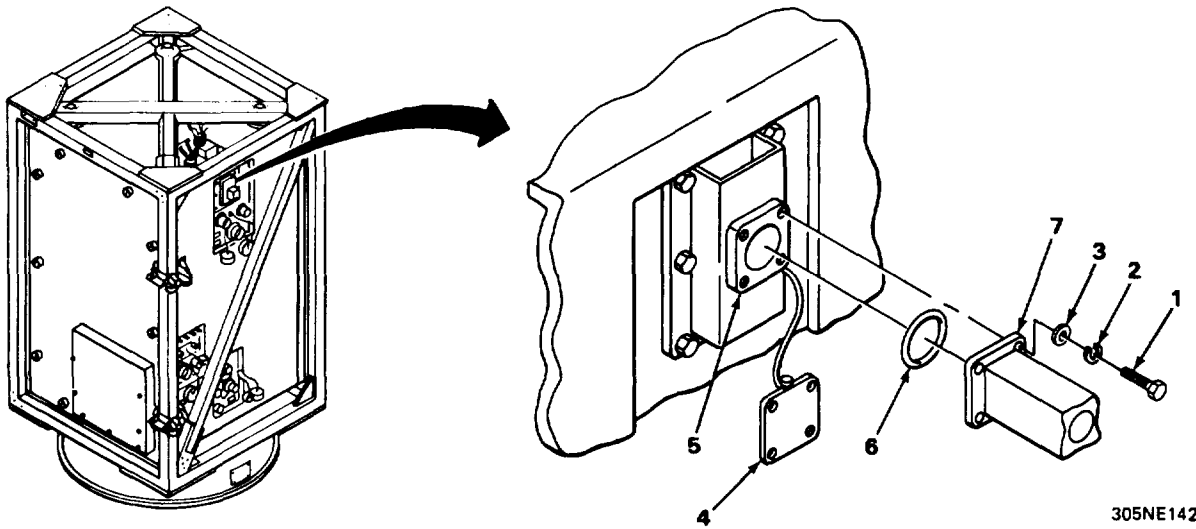

305NE142

10. Remove four screws (1), lockwasher (2), and flat washers (3) securing cover (4) on directional coupler output flange (5).
11. Insert preformed packing (6) into recess in flange on free end of directional coupler (7). Using four screws (1), lockwashers (2), and flat washers (3), secure directional coupler to directional coupler output flange (5).

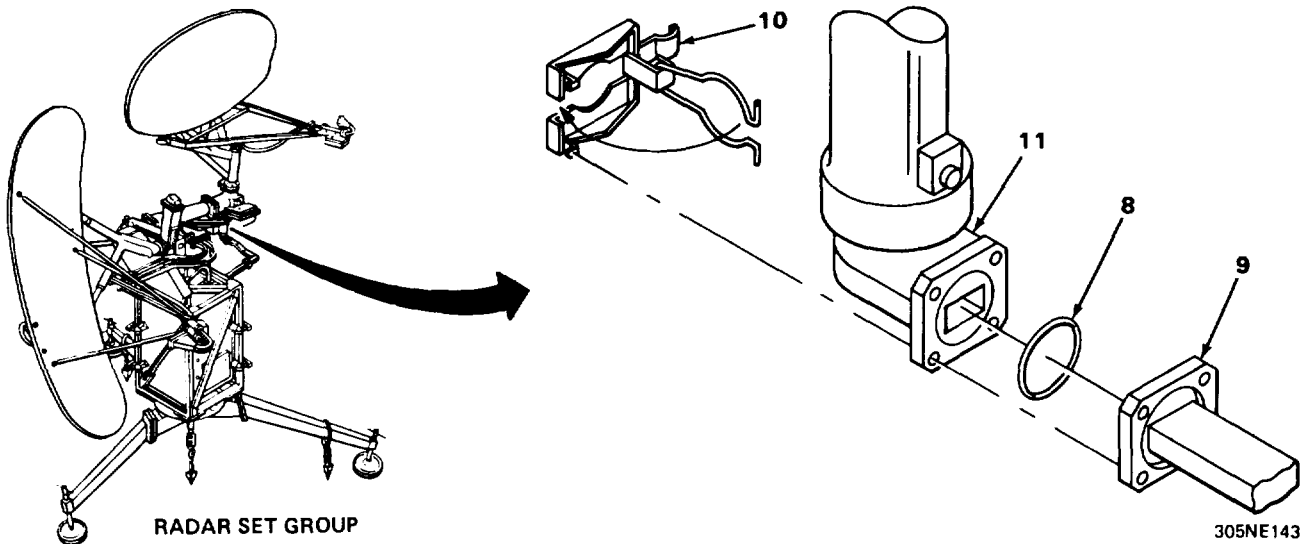

RADAR SET GROUP

305NE143

12. Install preformed packing (8) into recess in flange on free end of rigid waveguide assembly (9). Using waveguide coupling (10), connect rigid waveguide assembly to rotary joint waveguide (11) on azimuth antenna drive.

4-19. WAVEGUIDES INSTALLATION. (CONT)

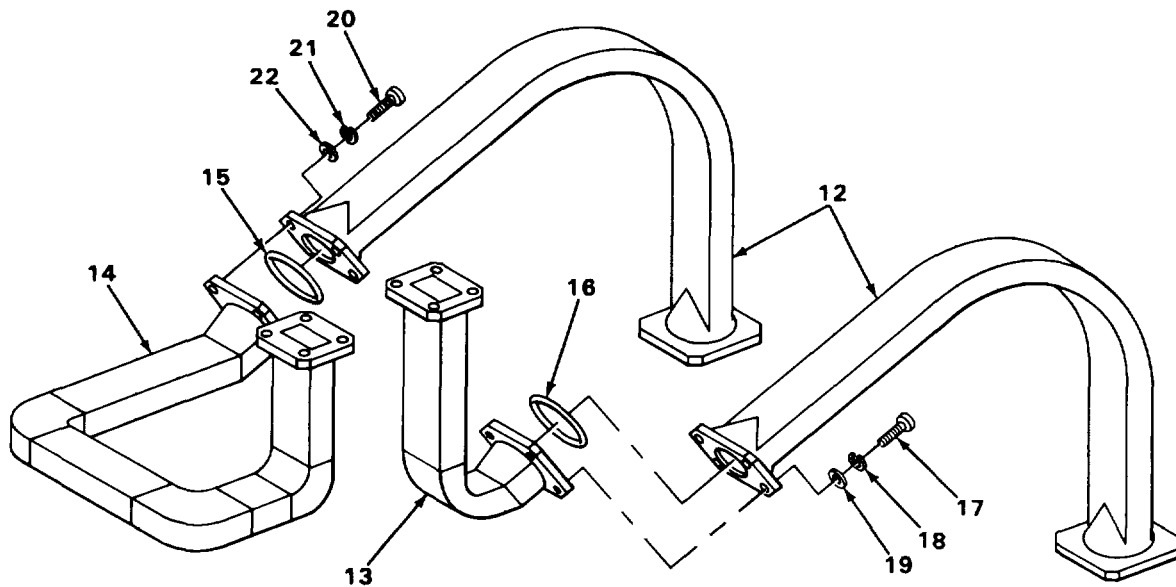

305NE144

NOTE

There are two identical flexible waveguides PN 140787-1 supplied with the radar set. Both are interchangeable in steps 13,14, and 15.

13. Locate two flexible waveguides PN 140787-1 (12), rigid waveguide PN 140768-1 (13), and rigid waveguide PN 140769-1 (14) on shipping pads.
14. Insert preformed packings (15 and 16) into recesses in flanges of rigid waveguides
15. Using four screws (17), lockwashers (18), and flat washers (19), connect one flexible waveguide (12) to rigid waveguide (13).
16. Using four screws (20), lockwashers (21), and flat washers (22), connect the other flexible waveguide (12) to rigid waveguide (14).

4-19. WAVEGUIDES INSTALLATION. (CONT)

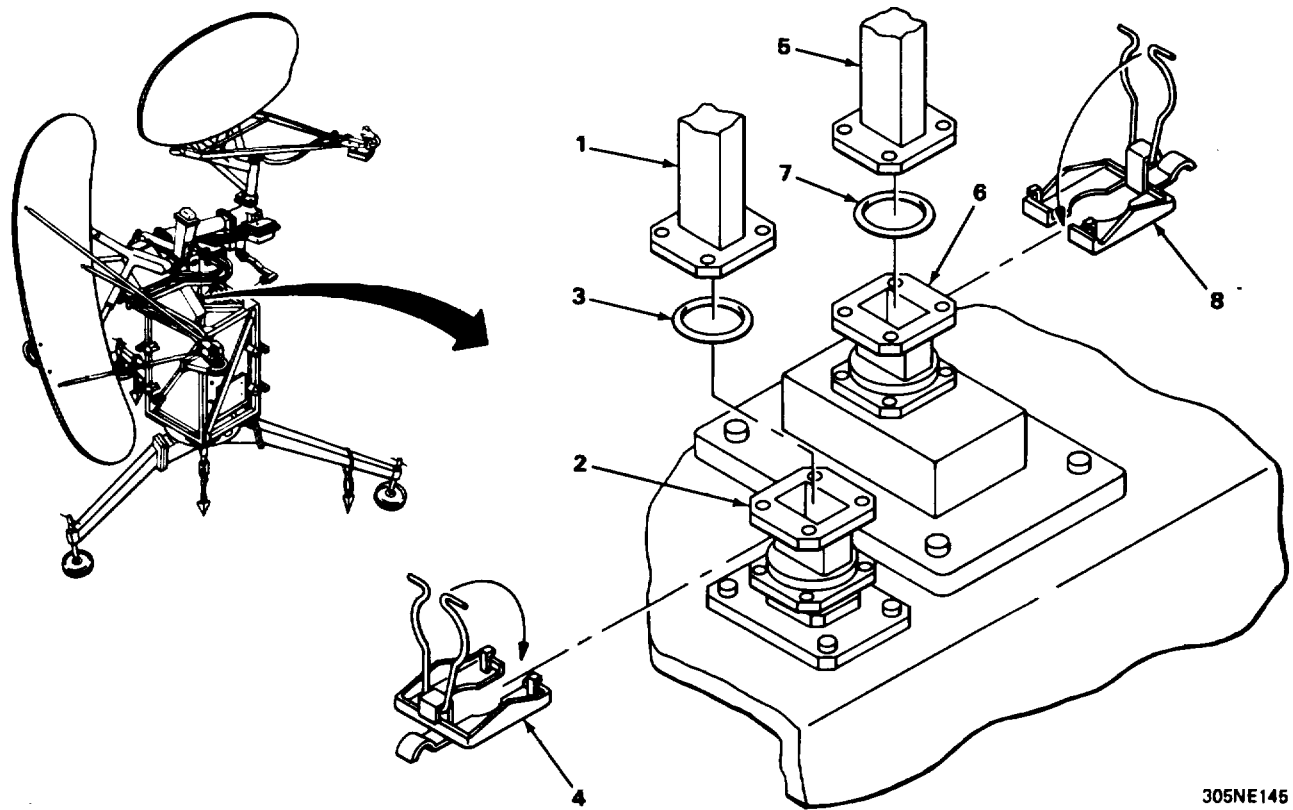

305NE145

17. Connect flexible waveguide (1), which is assembled to rigid waveguide PN 140768-1, to waveguide flange (2) by inserting preformed packing (3) into recess in flange and, using waveguide coupling (4), securing.
18. Connect the other flexible waveguide (5) to elevation attenuator (6) by inserting preformed packing (7) into recess in flange and, using waveguide coupling (8), securing.

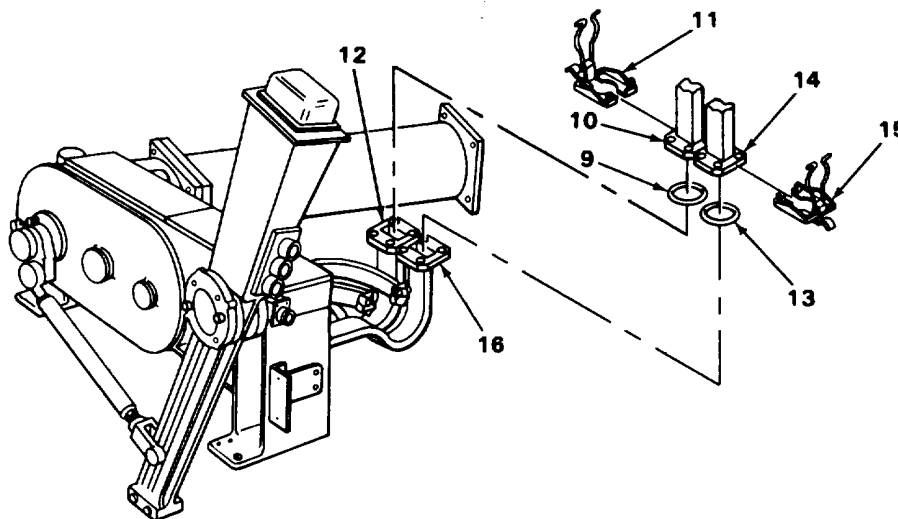

305NE146

4-19. WAVEGUIDES INSTALLATION. (CONT)

19. Insert preformed packing (9) in groove in flange of rigid waveguide (10). Using waveguide coupling (11), connect to elevation drive waveguide flange (12).
20. Insert preformed packing (13) in groove in flange of rigid waveguide (14). Using waveguide coupling (15), connect to elevation waveguide coupling (16).

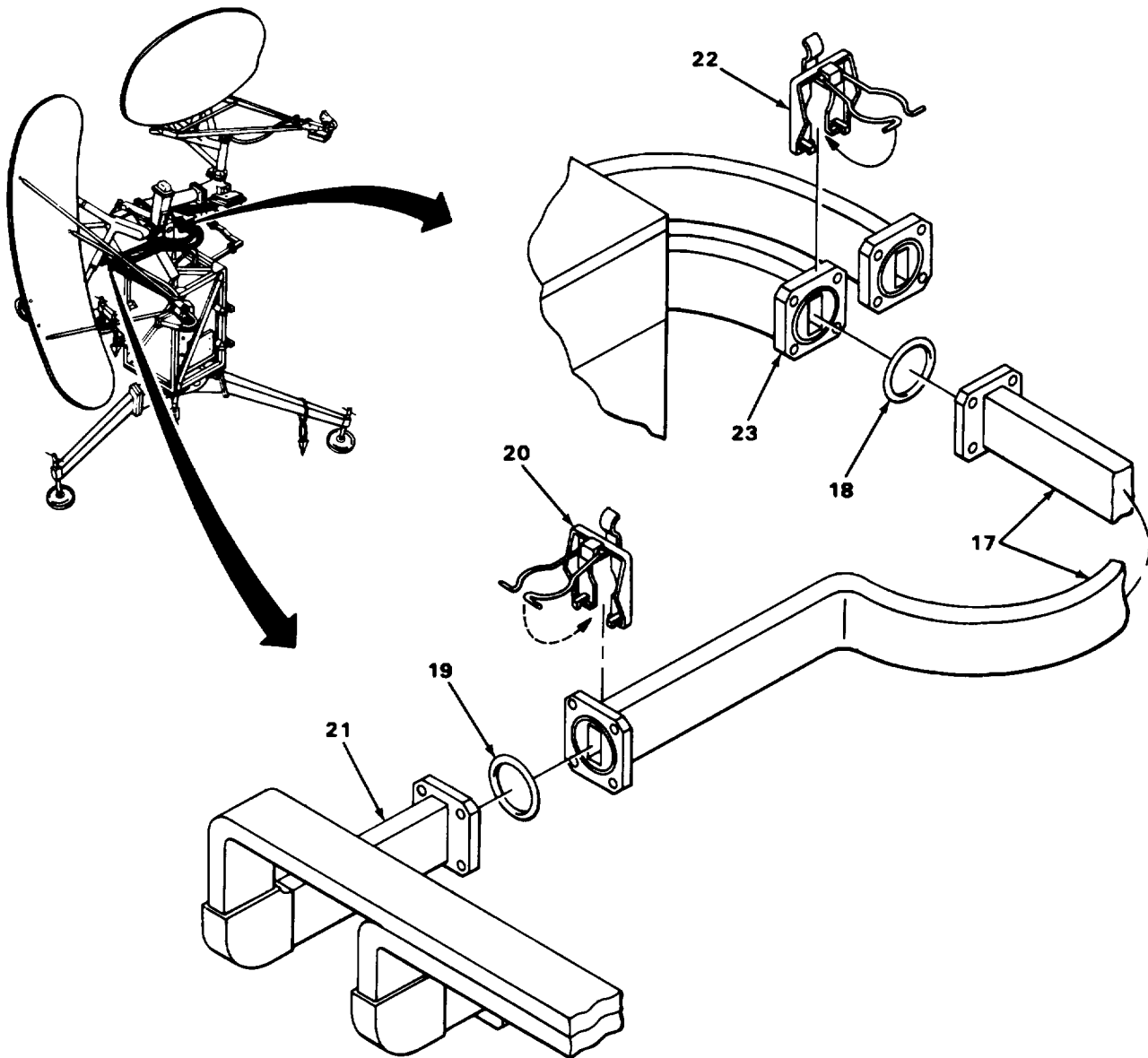

305NE147

21. Locate flexible waveguide PN 102823-5 (17) on shipping pad.
22. Insert preformed packings (18 and 19) into recesses in flanges on both ends of flexible waveguide (17).
23. Using waveguide coupling (20), connect flexible waveguide (17) to elevation antenna waveguide flange (21) (nearest to elevation antenna reflector).
24. Using waveguide coupling (22), connect other end of flexible waveguide (17) to rotary coupler (23) on elevation antenna drive.

4-19. WAVEGUIDES INSTALLATION. (CONT)

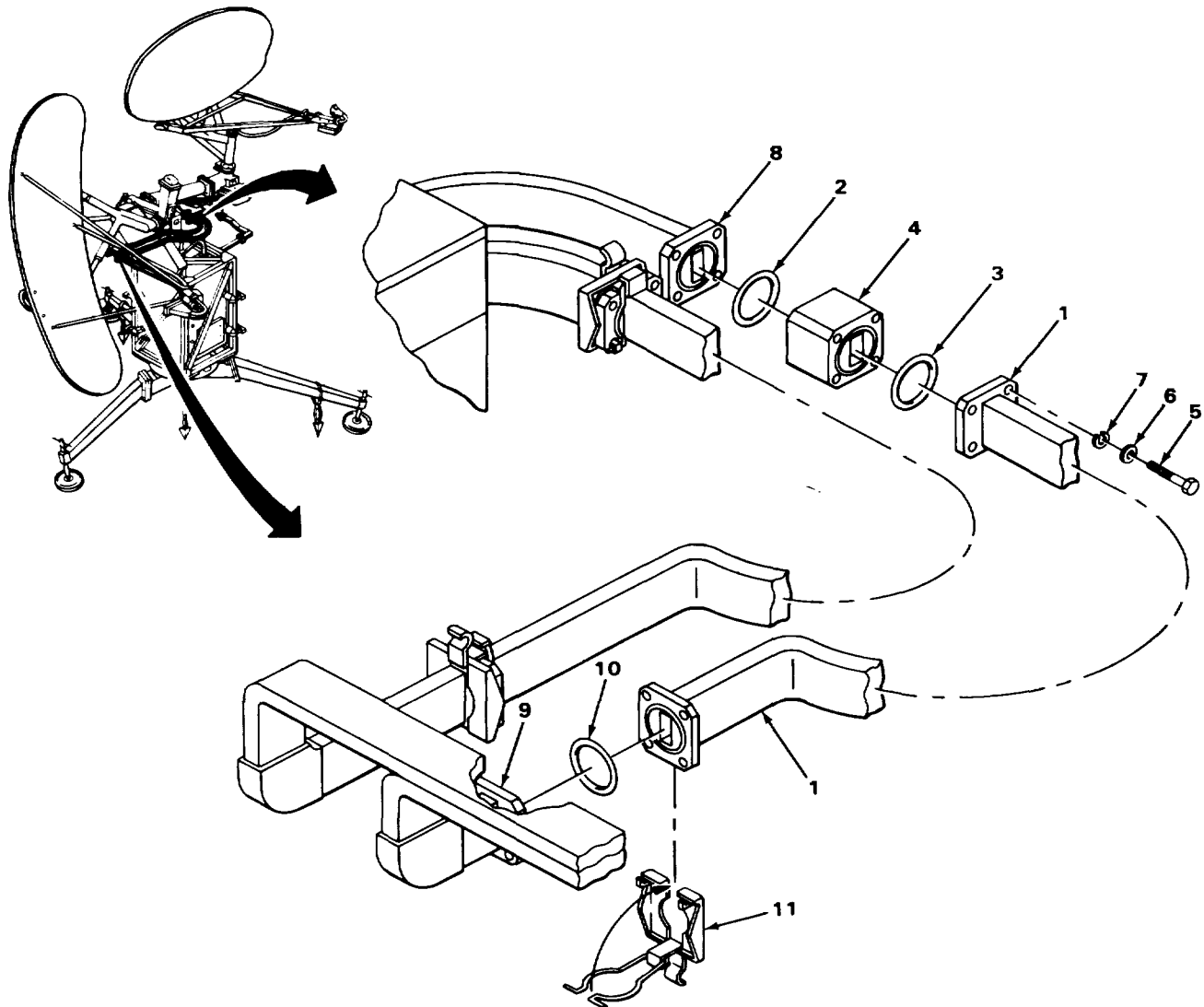

25. Locate flexible waveguide PN 102823-6 (1) on shipping pad.
26. Insert preformed packings (2 and 3) into recesses in waveguide adapter (4). Using four screws (5), flat washers (6), and lockwashers (7), assemble waveguide adapter (4) and flexible waveguide (1) to rotary coupler (8).
27. Connect other end of flexible waveguide (1) to elevation antenna waveguide flange (9) by inserting preformed packing (10) in recess of flange and securing with waveguide coupling (11).

305NE148

4-20. SITING SCOPE INSTALLATION.

The siting scope, which is located in the transmitter door, is used during target simulators orientation, ground angle determination, and radar set group orientation. The siting scope may be installed in any one of three locations, depending on the procedure being performed. Install the siting scope as necessary and remove and store in transmitter door when no longer required.

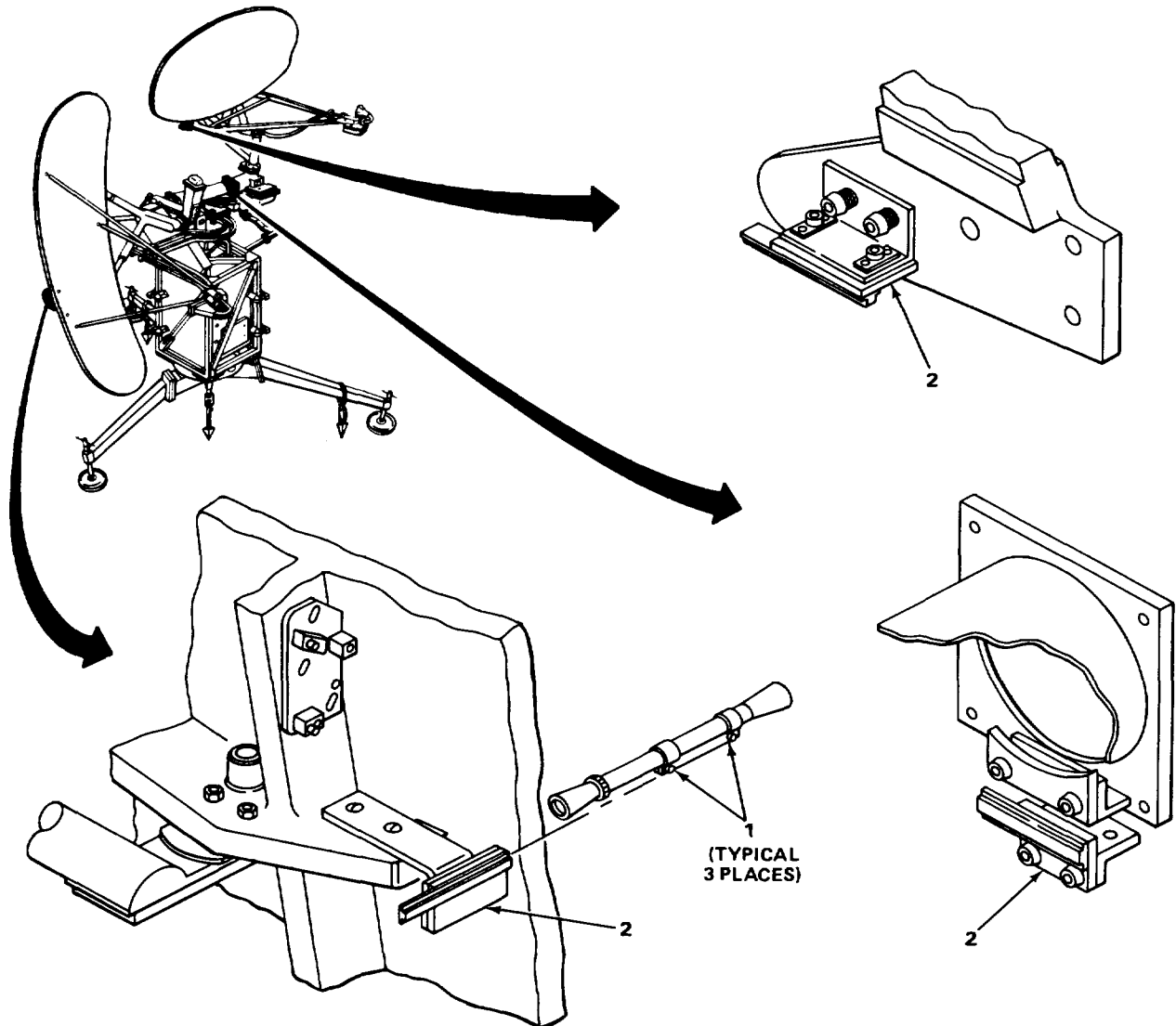

305NE149

CAUTION

Do not attempt to reposition or otherwise disturb siting scope mounts. These mounts have been prealigned to radar set and moving them will cause invalid radar set group alignments.

1. Loosen two knurled nuts (1) on siting scope and slide scope onto siting scope mount (2).
2. Tighten two knurled nuts loosened in step 1.

4-21. CLINOMETER INSTALLATION.

The clinometer, which is stored in the receiver door, is used during Ground Angle Determination (para 4-25), Siting of Target Simulators (para 4-26), and Preliminary Servicing and Adjustment (para 4-27). The clinometer may be installed in one of two places (see illustration below), depending on the procedure being performed. Install the clinometer as necessary and remove and store in receiver door when no longer required.

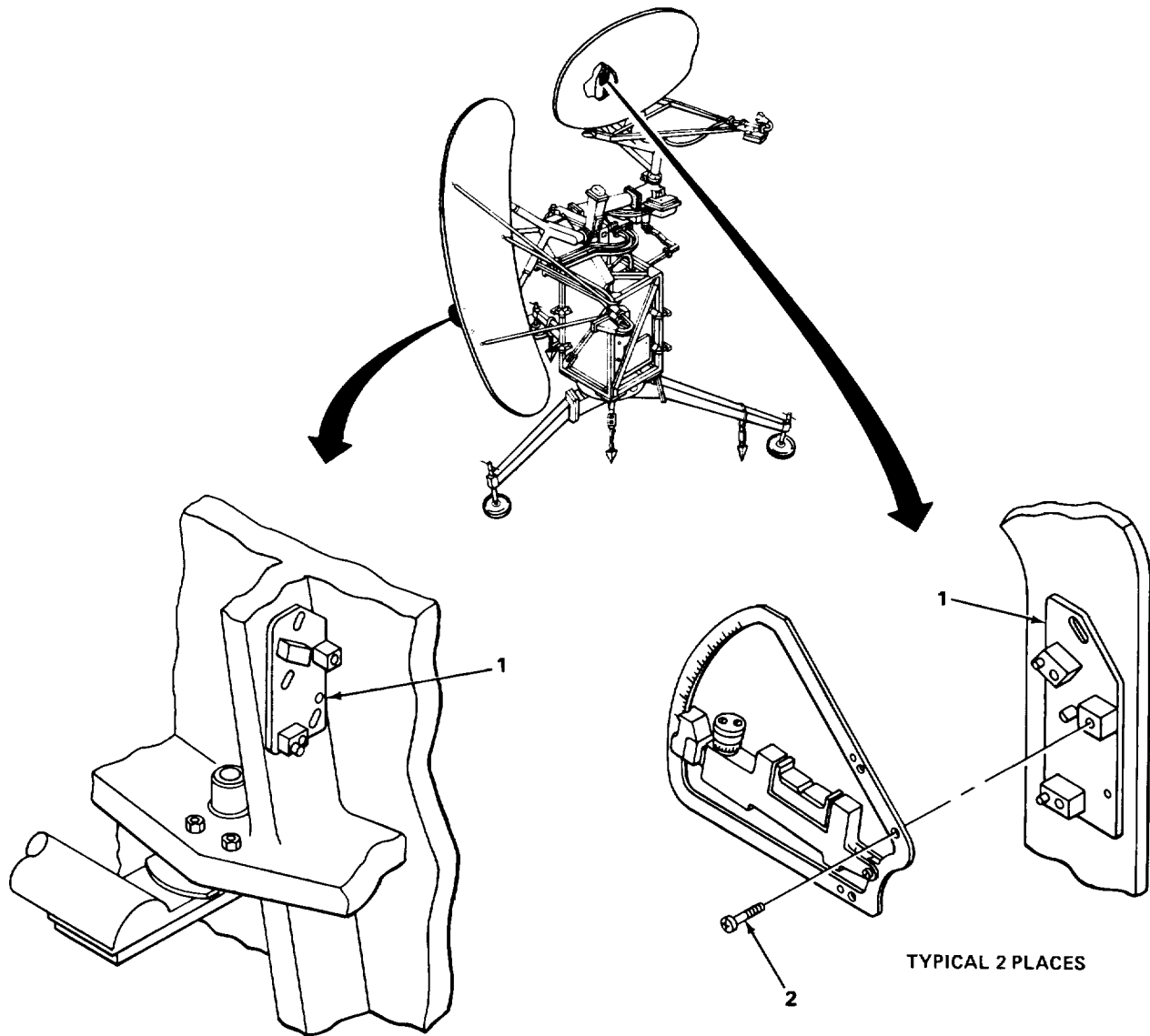

305NE150

Install clinometer on clinometer mount (1) and, using three screws (2), secure.

4-22. INDICATOR RAIN SHIELDS AND DEFLECTORS INSTALLATION.**NOTE**

Indicator rain shields and deflectors are Installed on control-indicators when radar set is not installed as part of landing control system. Refer to TM 11-5895-474-12 addendum when radar set is Installed as part of Landing Control Central AN/TSQ-71 B.

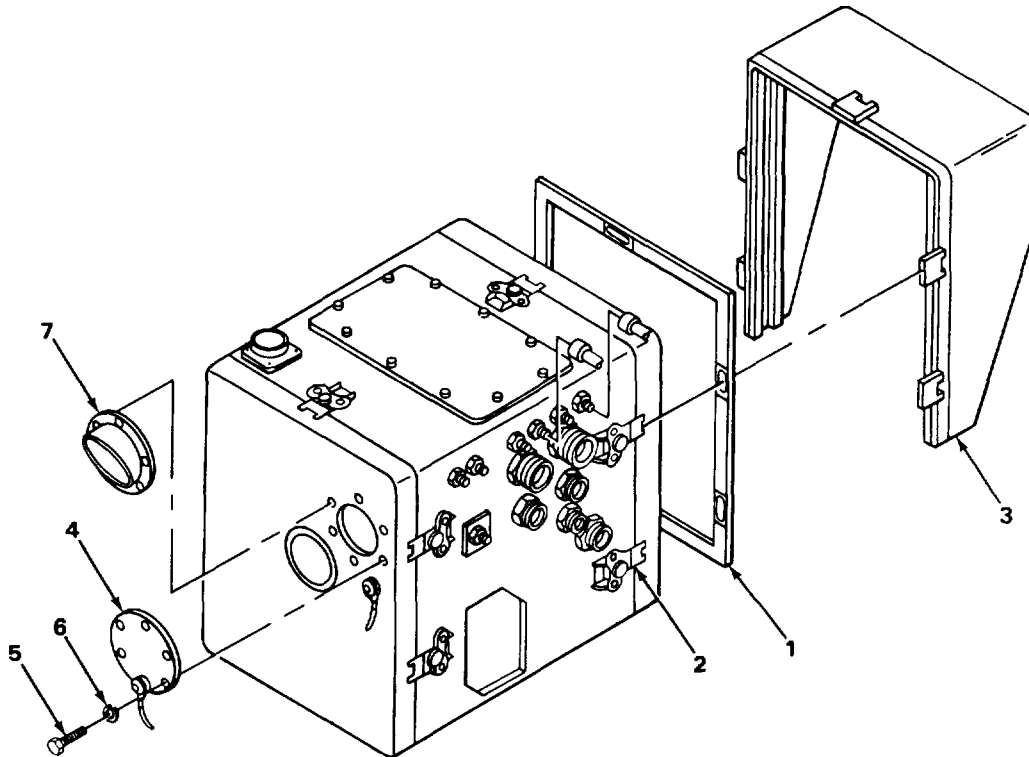

305NE036

1. Remove indicator cover (1) by unlatching five link locks (2) on front of control-indicator.
2. Install indicator rain shield (3) on front of control-indicator and secure with five link locks (2).
3. Remove access cover (4) from rear of control-indicator by removing six attaching screws (5) and lockwashers (6).
4. Using six screws (5) and lockwashers (6) removed in step 3, Install indicator rain deflector (7) on rear of control-indicator.

4-23. INTERCONNECTING CABLES.**NOTE**

Cabling instructions below are used when radar set is not Installed as part of landing control central system. Refer to TM 11-5895-474-12 addendum when radar set is Installed as part of Landing Control Central ANITSQ-71 B.

4-23. INTERCONNECTING CABLES. (CONT)

Interconnecting cables are installed after radar set has been assembled and installed. See FO-1, the Interconnecting cable diagram, when Installing interconnecting cables. The lengths of cables W3001, W3002, and W3005 will permit a maximum distance of 250 feet (76 m) between receiver-transmitter and master control-indicator. Ac power cables W3003 and W3004 are 135 feet (41 m) long and will permit receiver-transmitter and master control-indicator to be separated a maximum of 135 feet (41 m) each from ac power distribution box. Cables W9501, W9502, W9503, and W9504 connect master control-indicator to slave control-indicator and are each 25 feet (7.5 m) long. Ac power cable W3007 is 8 feet (2.5 m) long and connects ac power source to ac power distribution box.

INTERCONNECTING CABLE IDENTIFICATION

The table below identifies Interconnecting cables and their connection points on the associated equipment.

| CABLE PLUG | FROM | | | TO | | |
|------------|---------------------------|-------|------------|---------------------------|------------|-------|
| | EQUIPMENT | JACK | CABLE PLUG | EQUIPMENT | JACK CABLE | |
| W3001 | Receiver-Transmitter | J104 | P104 | Master Control- | J604 | P604 |
| W3002 | Receiver-Transmitter | J102 | P102 | Master Control- | J602 | P602 |
| W3003 | Receiver-Transmitter | J101 | P101 | AC Power Distribution Box | J9601 | P9601 |
| W3004 | AC Power Distribution Box | J9602 | P9602 | Master Control-Indicator | J601 | P601 |
| W3005 | Receiver-Transmitter | J103 | P103 | Master Control- | J603 | P603 |
| W3006 | Receiver-Transmitter | E101 | --- | Grounding Rod | --- | --- |
| W3007 | AC Power Distribution | J9603 | P9603 | AC Power Source | --- | --- |
| W9501 | Master Control-Indicator | J605 | P605 | Slave Control-Indicator | J601 | P601A |
| W9502 | Master Control-Indicator | J606 | P606 | Slave Control-Indicator | J602 | P602A |

4-23. INTERCONNECTING CABLES. (CONT)

| FROM | | | | TO | | |
|--------------|---|------|------------|-------------------------|-------|-------|
| CABLE | EQUIPMENT | JACK | CABLE PLUG | EQUIPMENT | JACK | CABLE |
| W9503 | Master Control-Indicator | J607 | P607 | Slave Control-Indicator | J603 | P603A |
| W9504 | Master Control-Indicator | J604 | P604 | Slave Control-Indicator | J604 | P604A |
| W9101 (2) | Azimuth Actuator and Elevation Actuator | * | * | Azimuth Antenna Drive | J1002 | P1002 |
| | | * | * | Elevation Antenna Drive | J504 | P504 |
| W9201 | Elevation Horn and Polarizer Assembly | * | * | Elevation Antenna Drive | J505 | P505 |
| W9301 | Azimuth Horn and Polarizer Assembly | * | * | Azimuth Antenna Drive | J1004 | P1004 |
| W3501 | Receiver-Transmitter | J107 | P107 | Azimuth Antenna | J1001 | P1001 |
| W3502 | Receiver-Transmitter | J108 | P108 | Azimuth Antenna Drive | J1003 | P1003 |
| W3503 | Receiver-Transmitter | J106 | P106 | Elevation Antenna Drive | J501 | P501 |
| W501 | Elevation Antenna Drive | J503 | P503 | Elevation Antenna Drive | J502 | P502 |

*This end of cable is hardwired to corresponding equipment.

4-23. INTERCONNECTING CABLES. (CONT)

INTERCONNECTING CABLE INSTALLATION

Referring to FO-1, interconnecting cable diagram, install interconnecting cables as described in the following steps.

Radar Site

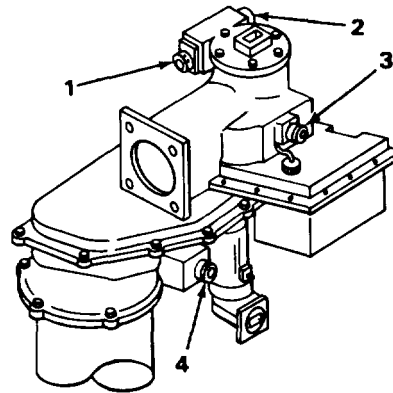

305NE162

1. Connect following cables to azimuth antenna drive as indicated:
 - a. Connect P1004 of cable W9301 (hardwired to azimuth horn and polarizer) to J1004 (1).
 - b. Connect P1002 of cable W9101 (hardwired to azimuth servo actuator) to J1002 (2).
 - c. Connect P1001 of cable W3501 to J1001 (3).
 - d. Connect P1003 of cable W3502 to J1003 (4).

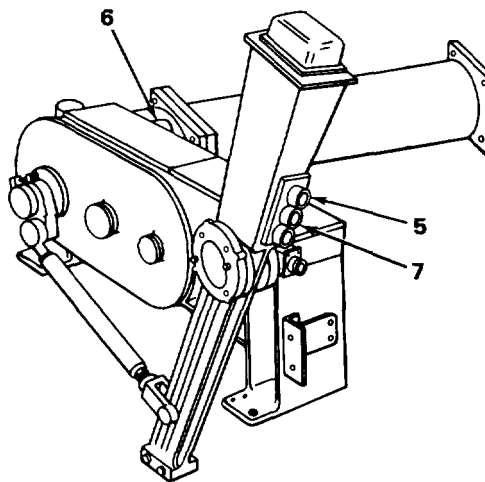

305NE163

2. Connect following cables to elevation antenna drive as indicated:
 - a. Connect P504 of cable W9101 (hardwired to elevation servo actuator) to J504 (5).
 - b. Connect P505 of W9201 (hardwired to elevation horn and polarizer) to J505 (6).
 - c. Connect P501 of cable W3503 to J501 (7).

4-23. INTERCONNECTING CABLES. (CONT)

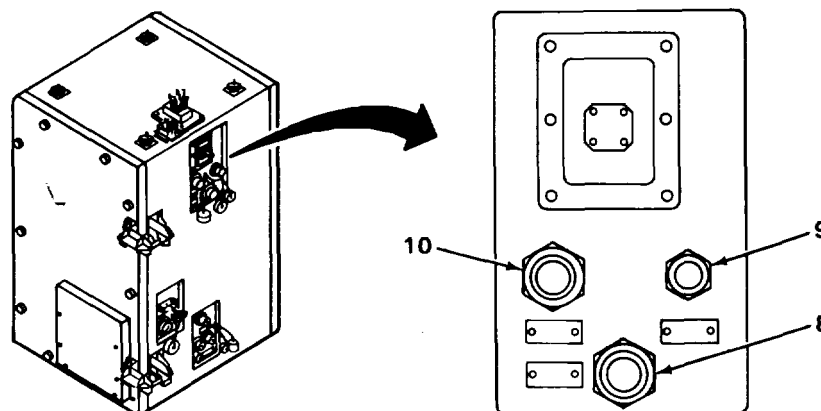

3. Connect following cables to receiver transmitter as indicated:

- a. Connect P107 of cable W3501 to J107 (8).
- b. Connect P108 of cable W3502 to J108 (9).
- c. Connect P106 of cable W3503 to J106 (10).

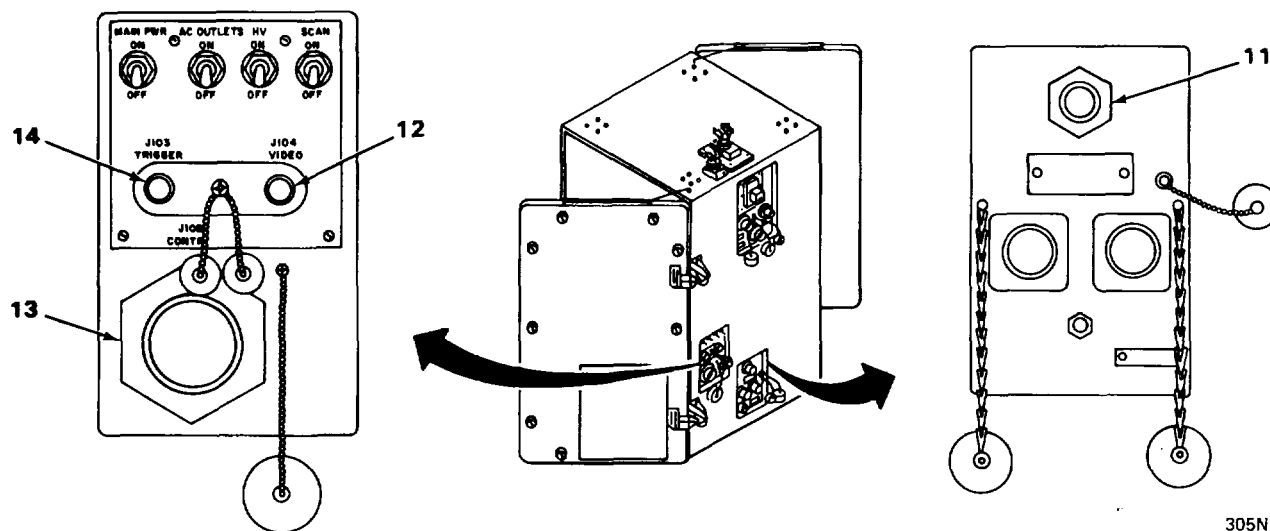

305NE165

- d. Connect P101 of cable W3003 to J101 (11).
- e. Connect P104 of cable W3001 to J104 (12).
- f. Connect P102 of cable W3002 to J102 (13).
- g. Connect P103 of cable W3005 to J103 (14).
- h. Connect one end of cable W3006 to grounding lugs E101.

4. Drive grounding rod 4 feet into ground within radius equal to length of grounding cable W3006. Connect loose end of cable to grounding rod.

4-23. INTERCONNECTING CABLES. (CONT)

INTERCONNECTING CABLE INSTALLATION (CONT)

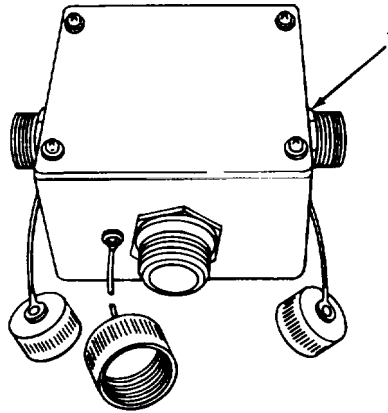

305NE166

5. Route cable W3003 from receiver-transmitter to ac power distribution box and connect P9601 (1) to J9601.
6. Route cables W3001, W3002, and W3005 from receiver-transmitter to master control-indicator (at operating site).

Operating Site

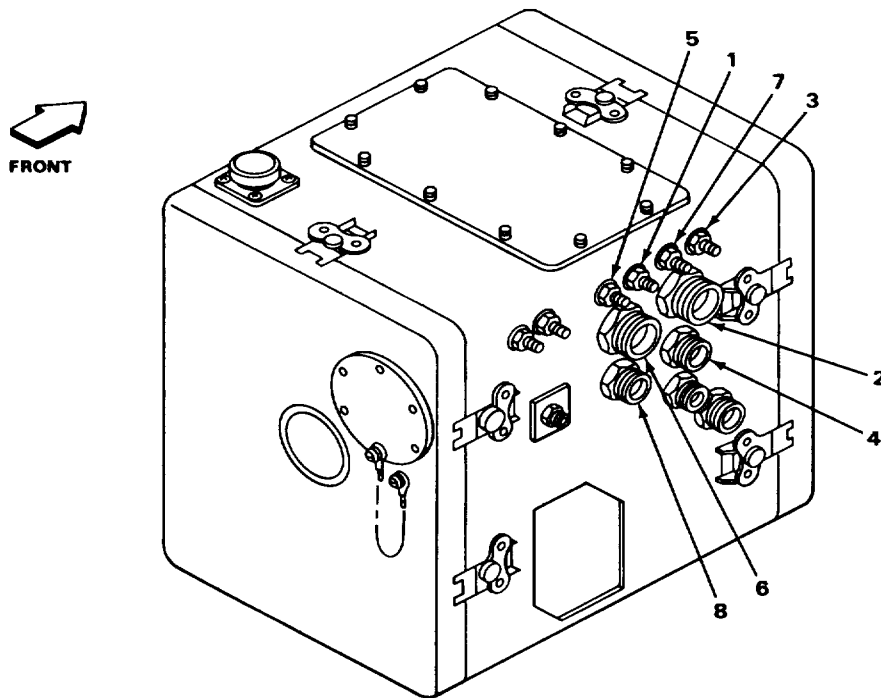

305NE167

4-23. INTERCONNECTING CABLES. (CONT)

7. Connect the following cables to master control-indicator as indicated:
 - a. Connect P604 of cable W3001 to J604 (1).
 - b. Connect P602 of cable W3002 to J602 (2).
 - c. Connect P603 of cable W3005 to J603 (3).
 - d. Connect P601 of cable W3004 to J601 (4).
 - e. Connect P608 of cable W9504 to J608 (5).
 - f. Connect P606 of cable W9502 to J606 (6).
 - g. Connect P607 of cable W9503 to J607 (7).
 - h. Connect P605 of cable W9501 to J605 (8).

8. Route cables W9501, W9502, W9503, and W9504 from master control-indicator to slave control-indicator.

NOTE

When performing step 9, location of connectors on slave control-indicator are identical to those on master control-indicator.

9. Connect the following cables to slave control-indicator as indicated:
 - a. Connect P604A of cable W3001 to J604.
 - b. Connect P602A of cable W3002 to J602.
 - c. Connect P603A of cable W3005 to J603.
 - d. Connect P601A of cable W3004 to J601.

10. Route cable W3004 from master control-indicator to ac power distribution box.

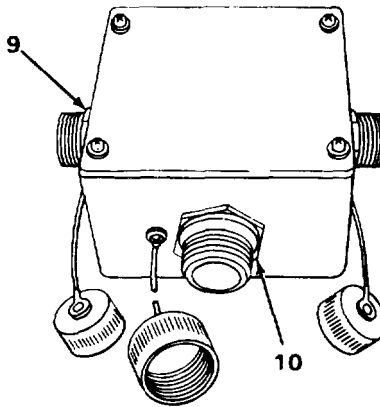

305NE168

11. Connect P9602 of cable W3004 to J9602 (9).
12. Connect P9603 of cable W3007 to J9603 (10).
13. Route cable W3007 from ac power distribution box to ac power source and connect terminal lugs of cable to ac power source.

4-24. RADAR SET GROUP LEVELING.

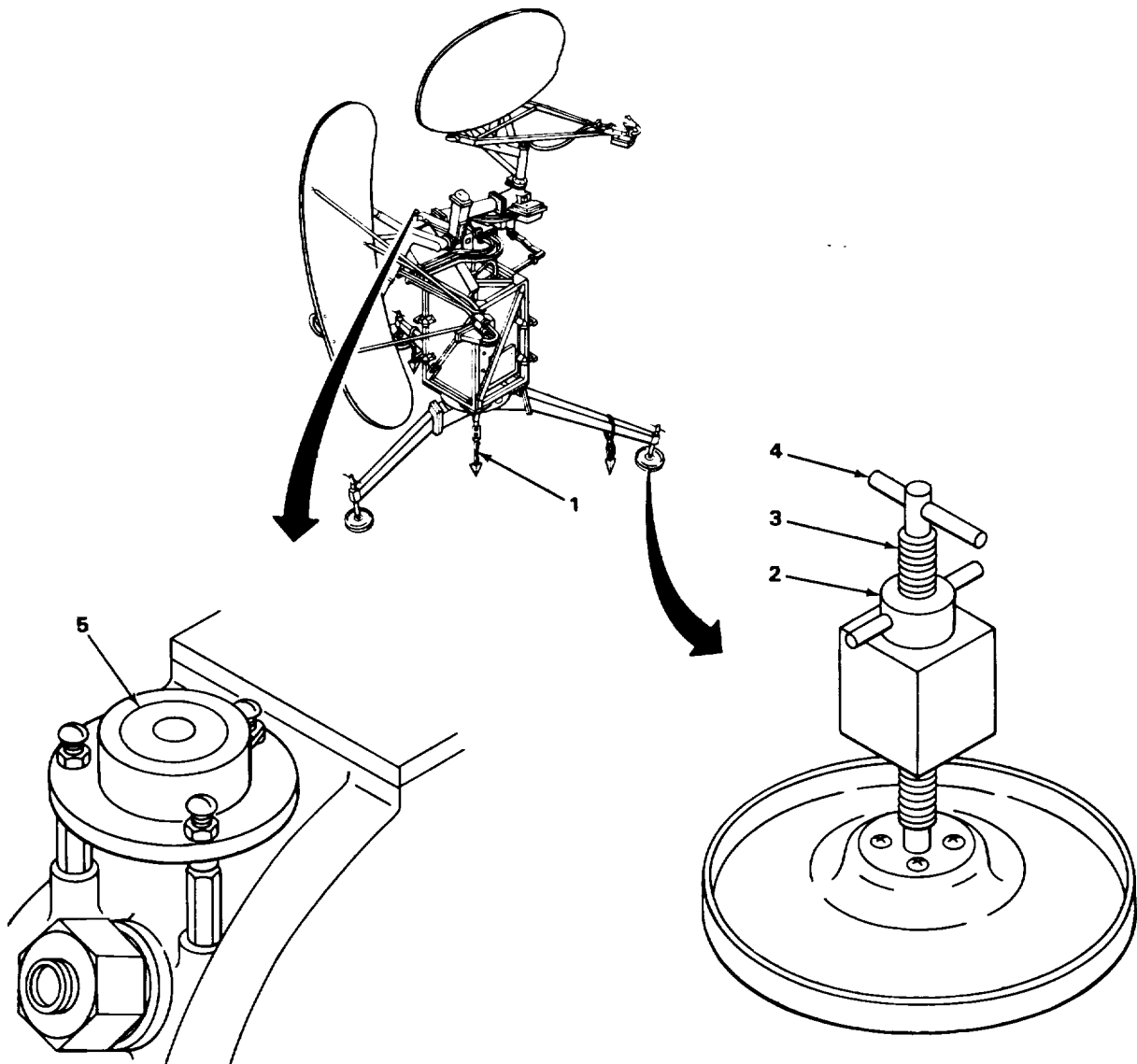

305NE178

1. Loosen strap ratchet (1) on center section of antenna pedestal.
2. Loosen locking collar (2) on leveling jackscrew (3) on appropriate leg (or legs).
3. Using handle (4), adjust leveling jackscrew (3) until bubble level (5) on top of elevation antenna drive indicates level.
4. Tighten locking collar (2) on leveling jackscrew (3).
5. Tighten strap ratchet on center section of antenna pedestal.

4-25. GROUND ANGLE DETERMINATION.

NOTE

If more than one runway approach is being used, determine and record the ground angle for each td point in accordance with steps 1 through 10.

If radar site is at a higher elevation than td point, resulting ground angle is negative and must not exceed - 1 degree.

It is possible that ground angle may have already been determined. See Site and Shelter Requirements, Equipment Siting Procedures (para 4-5). Even if this is true, ground angle must be checked using siting scope and clinometer, which are supplied as part of radar set. Siting scope, when used in conjunction with azimuth antenna scan protractor, serves as a theodolite or transit. Clinometer serves as an elevation scan protractor.

USING THE CLINOMETER

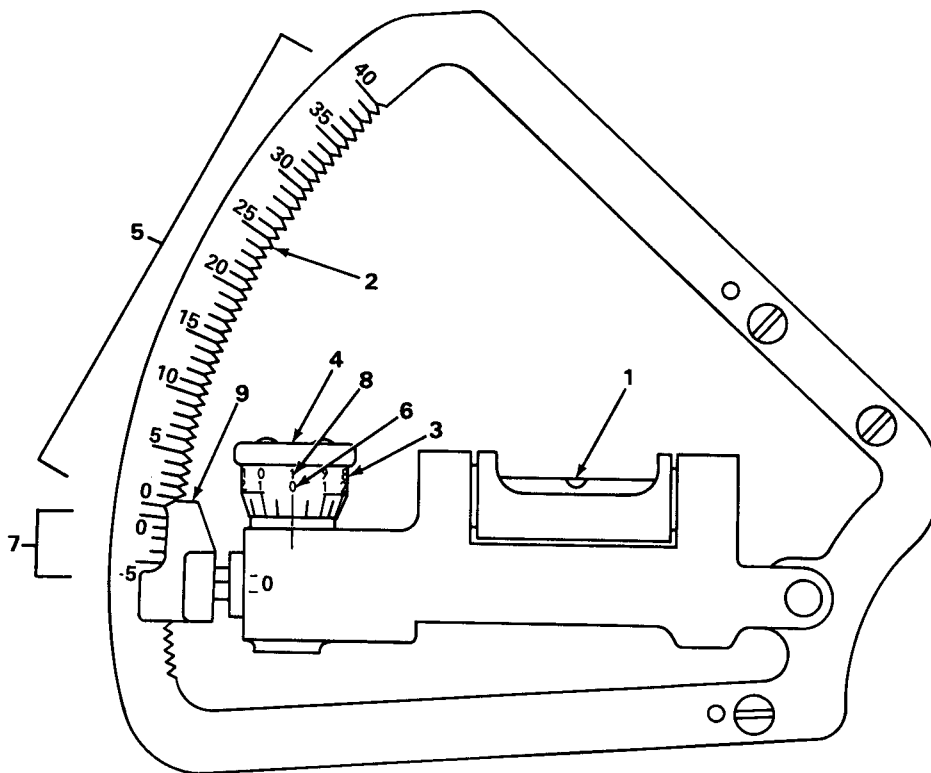

305NE094

The clinometer pictured above uses a bubble level (1) to determine the vertical angle of the elevation antenna. The degree scale (2) is adjustable between - 5 and 40 degrees in increments of 1 degree. The vernier scale (3) on the adjustment knob (4) has a 1-degree range, calibrated in 0.05-degree increments. The black degree markings, (5) on the degree scale and (6) on the vernier scale, are read as positive angles. The red degree markings, (7) on the degree scale and (8) on the vernier scale, are read as negative angles. For example, an angle of + 3.2 degrees would position the pointer (9) at the third notch above the black zero on the degree scale and at 0.2 on the black degree markings of the vernier scale. For an angle of - 3.2 degrees, the pointer would be three notches below the red zero on the degree scale and at 0.2 on the red degree vernier markings of the vernier scale.

4-25. GROUND ANGLE DETERMINATION. (CONT)

To use clinometer, move pointer until bubble level is approximately centered, then use vernier adjustment knob to perfectly center bubble level.

1. Install siting scope and clinometer on elevation antenna reflector. See Siting Scope Installation (para 4-20).
2. Check bubble level to ensure radar set group is level.
3. Manually position elevation antenna until clinometer reads level (zero-degree indication).
4. Mark stadia rod at a point representing the center of the elevation horn and polarizer.
5. Direct second person to hold stadia rod in a vertical position on td point.
6. Loosen but do not remove six screws in three strap clamps that secure receiver-transmitter to antenna pedestal.
7. Site through siting scope and manually rotate receiver-transmitter until stadia rod can be seen in siting scope.
8. Tighten six screws loosened in step 6.
9. Site through siting scope and manually position elevation antenna until horizontal crosshair is lined up with point marked on stadia rod in step 4. Maintain elevation antenna in this position.
10. Adjust clinometer pointer and vernier adjustment knob until bubble is centered. Record angle indicated on clinometer. This is ground angle to be used in elevation cursor alinement.

4-26. SITING OF TARGET SIMULATORS.

Reflections from radar-target simulators (target reflectors) appear on the control-indicator radar display as radar-target returns (blips). Target simulators are used to provide fixed reference points for alining radar set group and cursors, which are used during precision approach and height-finder operations, to the runway. Each target simulator must be accurately sited to ensure proper alinement of radar set group and cursors. Four methods are given for siting target simulators. Method one uses three target simulators for each runway approach. Method two requires two target simulators for each runway approach. Method three requires the use of a theodolite or transit, and stadia rod, which are used to site three target simulators. Method four also requires a theodolite or transit and stadia rod, but uses two target simulators. Select the method that best suits the needs of your radar site. If more than one runway approach is to be covered from one radar site, additional target simulators will be required, since only three are supplied with the radar set.

4-26. SITING OF TARGET SIMULATORS. (CONT)**NOTE**

Td point should be determined and marked before siting target simulators. When positioning target simulators, face grid side of simulator directly at radar set group.

METHOD ONE

TOOLS REQUIRED: Measuring tape

PERSONNEL REQUIRED: Two

Method one places two target simulators on opposite sides of runway bracketing td point, and one simulator on rpl. This method is used when the two simulators bracketing td point can be positioned at least 75 feet from clr and when there are no obstacles on sides of runway that would obscure radar returns from these target simulators.

NOTE

Method two should be used if the two target simulators bracketing td point cannot each be positioned at least 75 feet from clr, or if there are obstacles that will obscure radar returns from these simulators.

Read and become familiar with siting procedure in steps 1 through 6 before attempting to site target simulators.

Because a theodolite is not used in this method, distances are determined by lining up points by eye and then measuring the distances between points. Be as accurate as possible when lining up points; an error here will cause inaccuracies when siting target simulators.

4.26. SITING OF TARGET SIMULATORS. (CONT)

METHOD ONE (CONT)

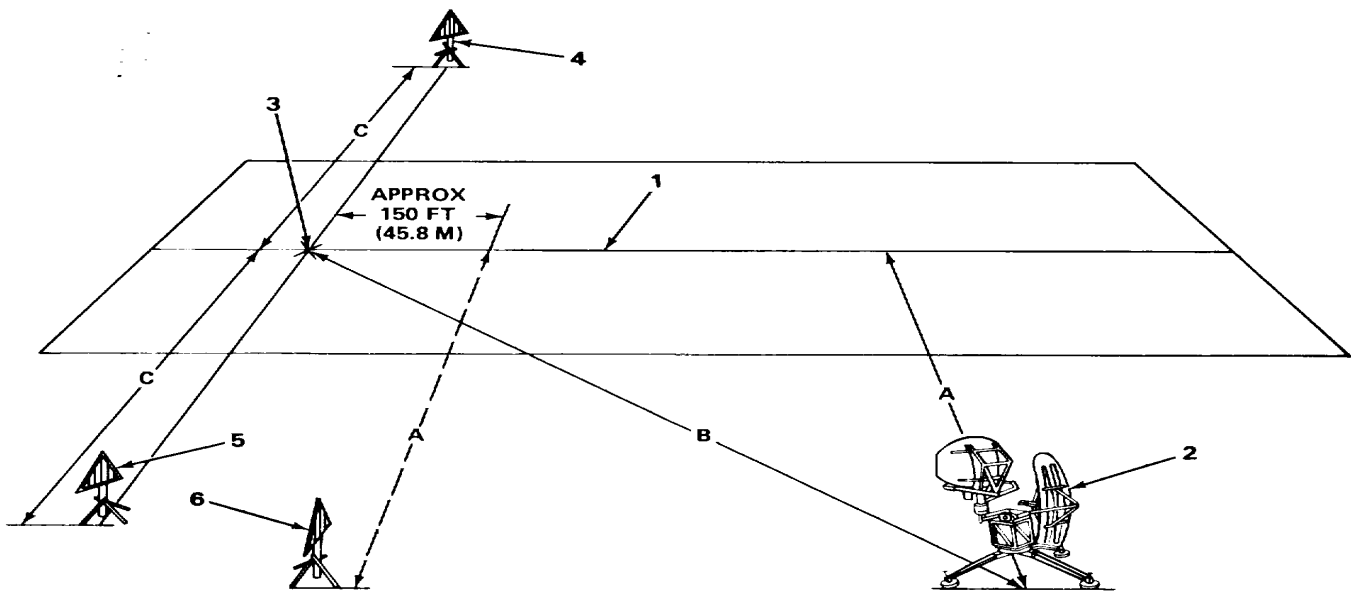

305NE216

1. Determine clr (1) by measuring width of runway and dividing by two.
2. Determine and record radar offset from clr distance (A) by measuring a straight line, perpendicular to clr (1), to center of radar set group (2).
3. Determine and record distance to td (B) by measuring a straight line from radar set group (2) to td point (3). This distance will be used in future cursor alinements (para 4-28).
4. Extend a straight line, at least 75 feet (22.9 m) long, from td point (3) away from radar set group side of runway and perpendicular to clr (1). Record this distance (C), and position first td bracketing target reflector (4) at this point.
5. Extend a straight line from td point (3) toward radar set group side of runway and perpendicular to clr (1), that is the same distance (distance C) as that recorded in step 4. Position second td bracketing reflector (5) at this point.
6. Select a point on clr (1) approximately 150 feet (45.8 m) in from td point (3) (this distance is not critical). Measure a straight line perpendicular to clr (1) through this point that is the same distance (dotted line A) as that recorded in step 2. Position rpl target reflector (6) at this point.

METHOD TWO

TOOLS REQUIRED: Measuring tape

PERSONNEL REQUIRED: Two

This method uses two target simulators for each runway approach, as opposed to method one, which uses three target reflectors for each approach. One target reflector is positioned at some point on clr beyond td point. The other reflector is positioned on rpl at a point that equals the distance between radar set group and td point.

4-26. SITING OF TARGET SIMULATORS. (CONT)

WARNING

Ensure placement of clr target reflector will not present any safety hazard to departing or approaching aircraft.

NOTE

Read and become familiar with siting procedure in steps 1 through 5 before attempting to site target simulators.

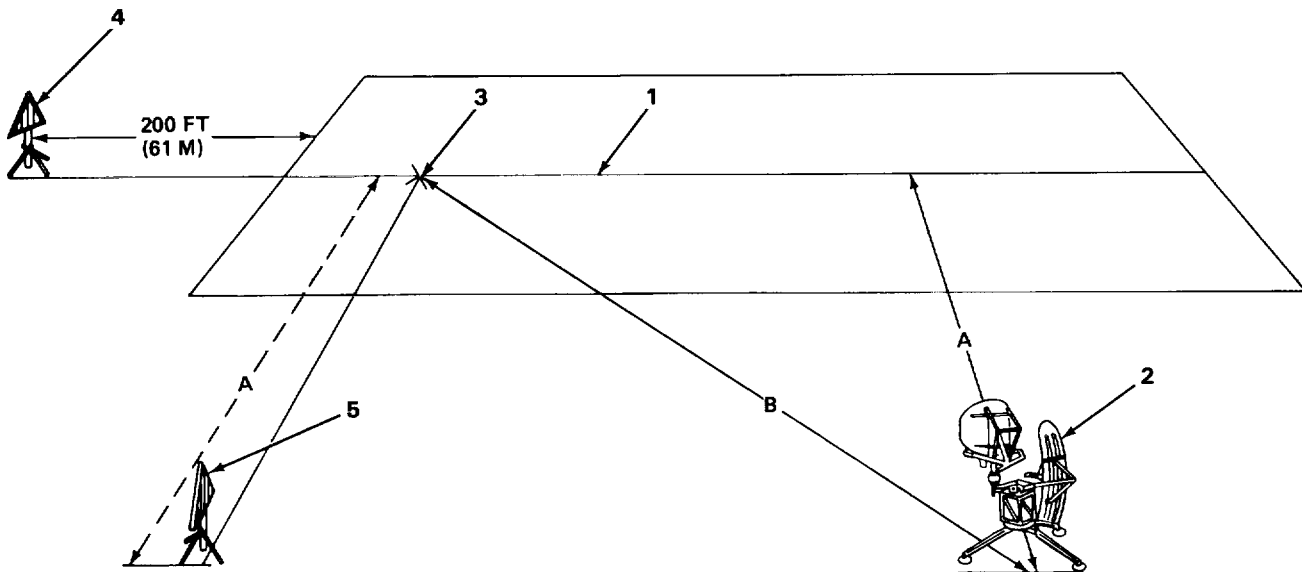

305NE217

1. Determine clr (1) by measuring width of runway and dividing by two.
2. Determine and record radar offset from clr distance (A) by measuring a straight line perpendicular to clr (1) to center of radar set group (2).
3. Determine and record distance to td (B) by measuring a straight line from radar set group (2) to td point (3). This distance will be used in future cursor alinements (para 4-28).
4. Position clr target reflector (4) on an extension of the clr (1) approximately 200 feet (61 m) beyond end of runway.
5. Extend a straight line from td point (3), toward radar set group side of runway and perpendicular to clr, that is the same distance (dotted line A) as that recorded in step 2. Place td-rpl target reflector (5) at this point.

4-26. SITING OF TARGET SIMULATORS. (CONT)

METHOD THREE

TOOLS REQUIRED: Theodolite or transit
10-foot stadia rod
Measuring tape

PERSONNEL REQUIRED: Two

Method three uses three target simulators for each runway approach, as in method one. This method requires the use of a theodolite, or transit, and stadia rod. It is more precise than method one but requires more time to accomplish.

NOTE

Method four should be used if the two target simulators bracketing td point cannot each be positioned at least 75 feet (22.9 m) from clr, or if there are obstacles that will obscure radar returns from these simulators.

Read and become familiar with siting procedure in steps 1 through 19 before attempting to site target simulators.

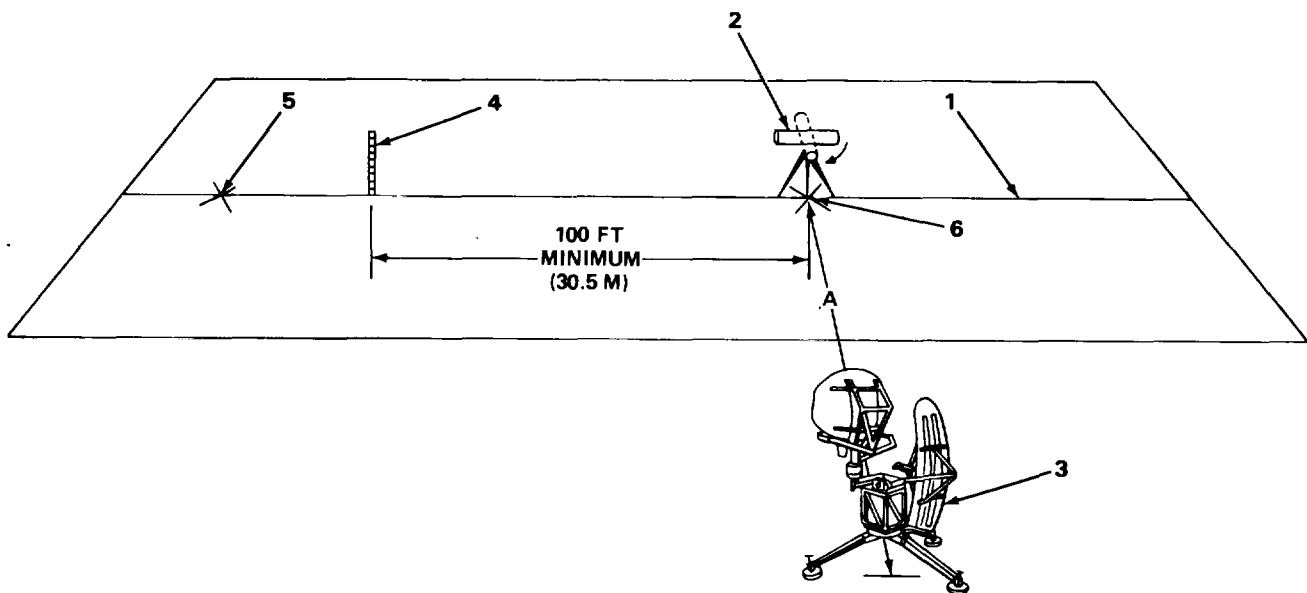

305NE080

1. Determine clr (1) by measuring width of runway and dividing by two.
2. Set up theodolite or transit (2) on clr directly opposite radar set group (3).
3. Direct second person to hold stadia rod (4) in a vertical position on clr 100 feet (30.5 m) or more toward td (5), facing theodolite.
4. Site vertical crosshair of theodolite on stadia rod (4). Record azimuth degree indication at theodolite reference mark.

4-26. SITING OF TARGET SIMULATORS. (CONT)

5. Rotate theodolite 90 degrees in azimuth toward radar set group (3) and lock in azimuth. Check that vertical crosshair of theodolite is lined up with vertical center of radar set group.

NOTE

If crosshair is lined up with vertical center of receiver-transmitter, proceed to step 6; if not, move theodolite in appropriate direction along clr and repeat procedure, beginning with step 4.

6. Mark point (6) on clr where theodolite is located. Measure distance from mark to center of radar set group (distance A).

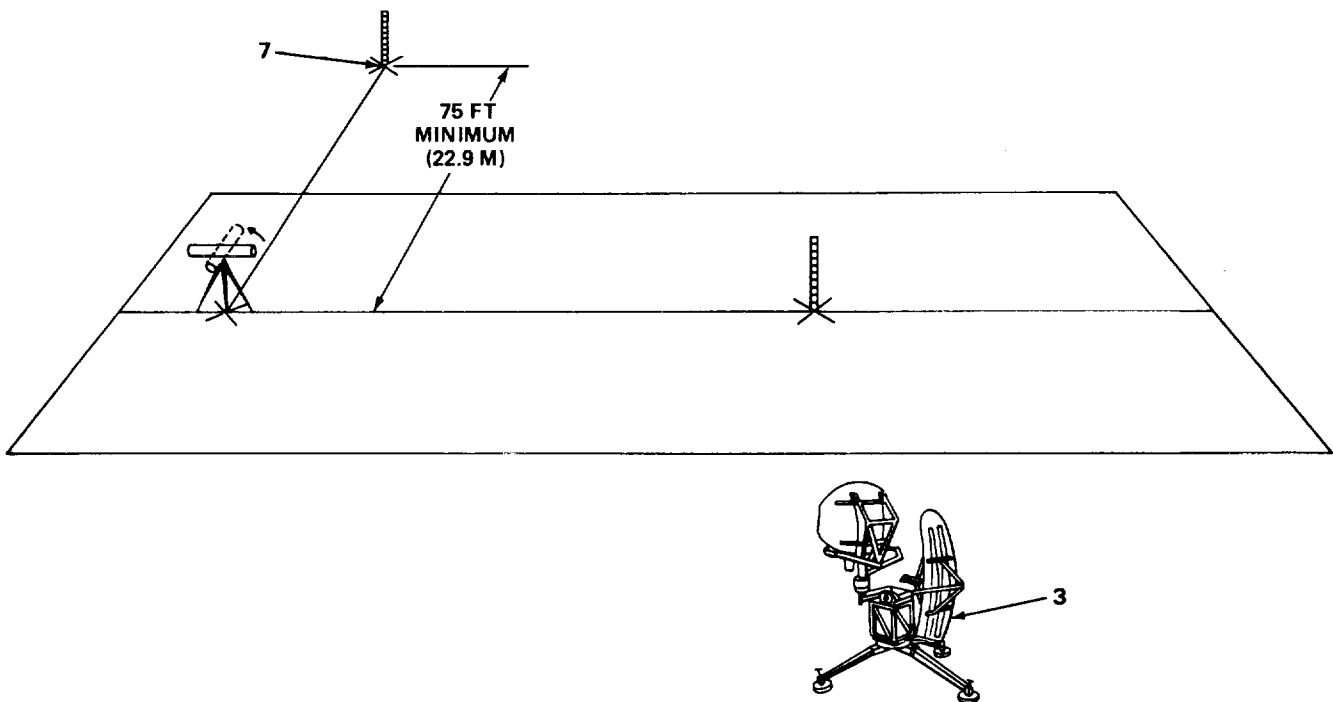

305NE081

7. Set up theodolite at td point on clr. Direct second person to hold stadia rod on point marked in step 6.
8. Sight vertical crosshair of theodolite on stadia rod. Record azimuth degree indication at theodolite reference mark.
9. Rotate theodolite 90 degrees in azimuth toward side of runway opposite radar set group (3) and lock in azimuth. Record azimuth degree indication at theodolite reference mark.

NOTE

Theodolite is pointing along a line perpendicular to clr passing through td point.

10. Direct second person to move stadia rod along this perpendicular line until it is a minimum of 75 feet (22.9 m) from clr and lined up with vertical crosshair of theodolite. Mark this point (7) and measure its distance from clr.

4-26. SITING OF TARGET SIMULATORS. (CONT)

METHOD THREE (CONT)

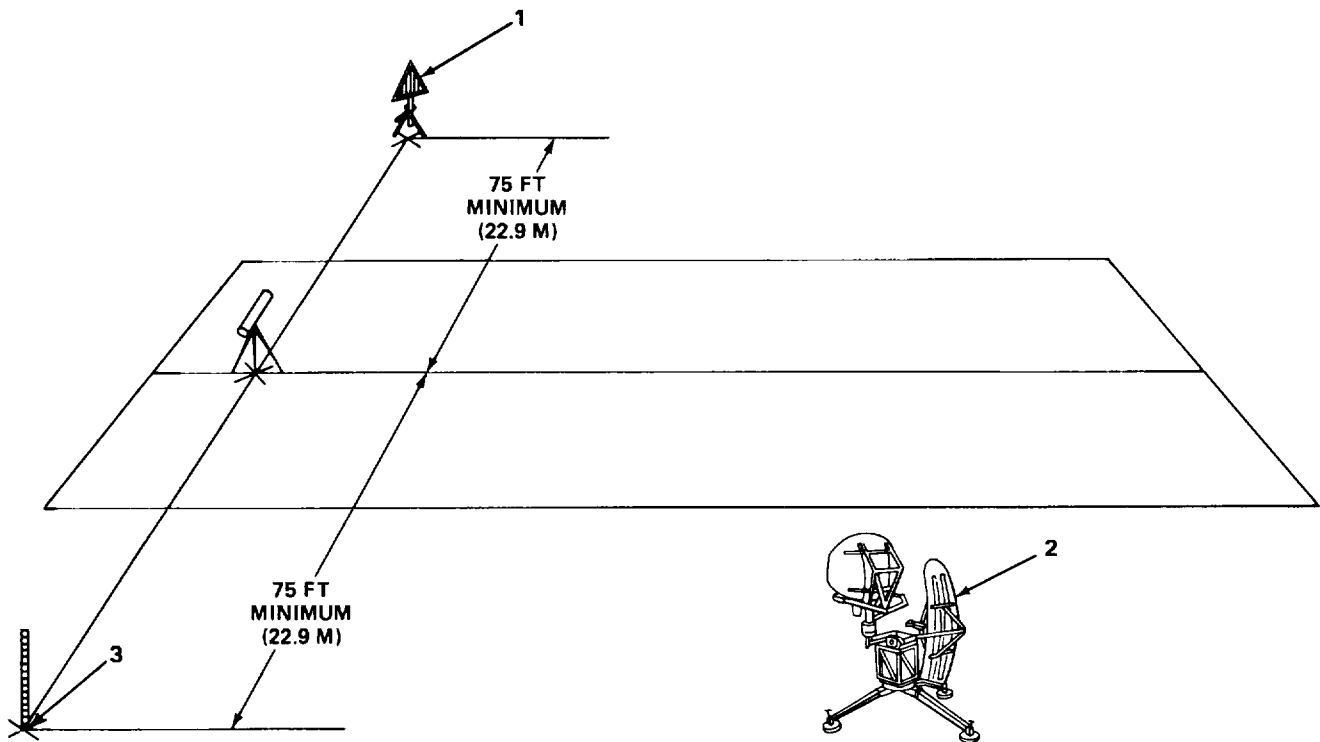

305NE082

11. Position first td bracketing reflector (1) at point marked in step 10.
12. Rotate theodolite 180 degrees in azimuth toward radar set group (2) side of runway. Lock in azimuth and record azimuth degree indication at theodolite reference mark.

NOTE

This extends the perpendicular line established in step 9 from CLR across other side of runway.

13. Direct second person to move stadia rod along this perpendicular line until it is the same distance from CLR as that recorded in step 10 and lined up with vertical crosshair of theodolite. Mark this point (3).

4-26. SITING OF TARGET SIMULATORS. (CONT)

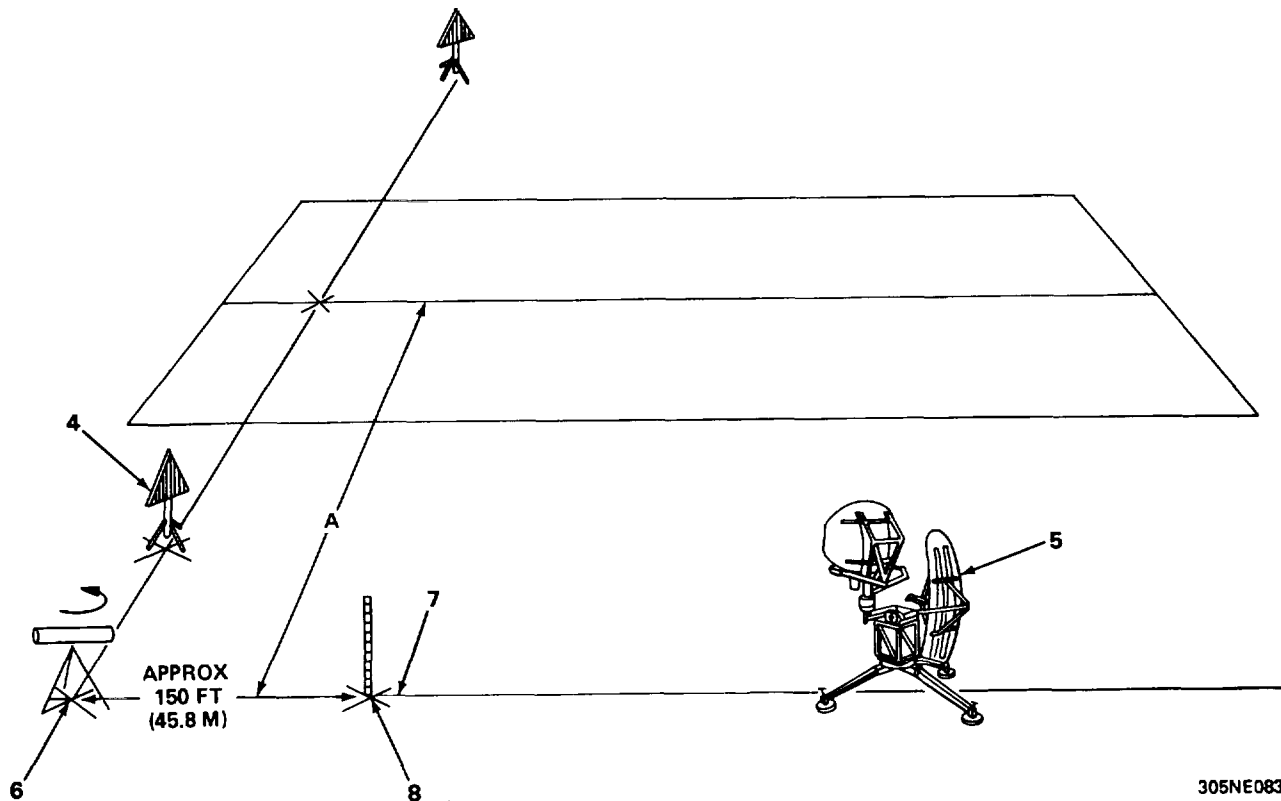

305NE083

14. Position second td bracketing reflector (4) at point marked in step 13.
15. Direct second person to continue to move stadia rod along perpendicular line (toward radar set group (5) side of runway) until it is at the same distance from clr as that recorded in step 6 (solid line A). Mark this point (6).
16. Set up theodolite at point marked in step 15 and site vertical crosshair on vertical center of receiver-transmitter group. Record azimuth indication at theodolite reference mark.

NOTE

Theodolite is now pointing along a line parallel to clr. This is the rpl (7).

17. Direct second person to move stadia rod along rpl (7) toward radar set group (5) until it is approximately 150 feet (45.8 m) from theodolite (this distance is not critical). Mark this point (8).

4-26. SITING OF TARGET SIMULATORS. (CONT)

METHOD THREE (CONT)

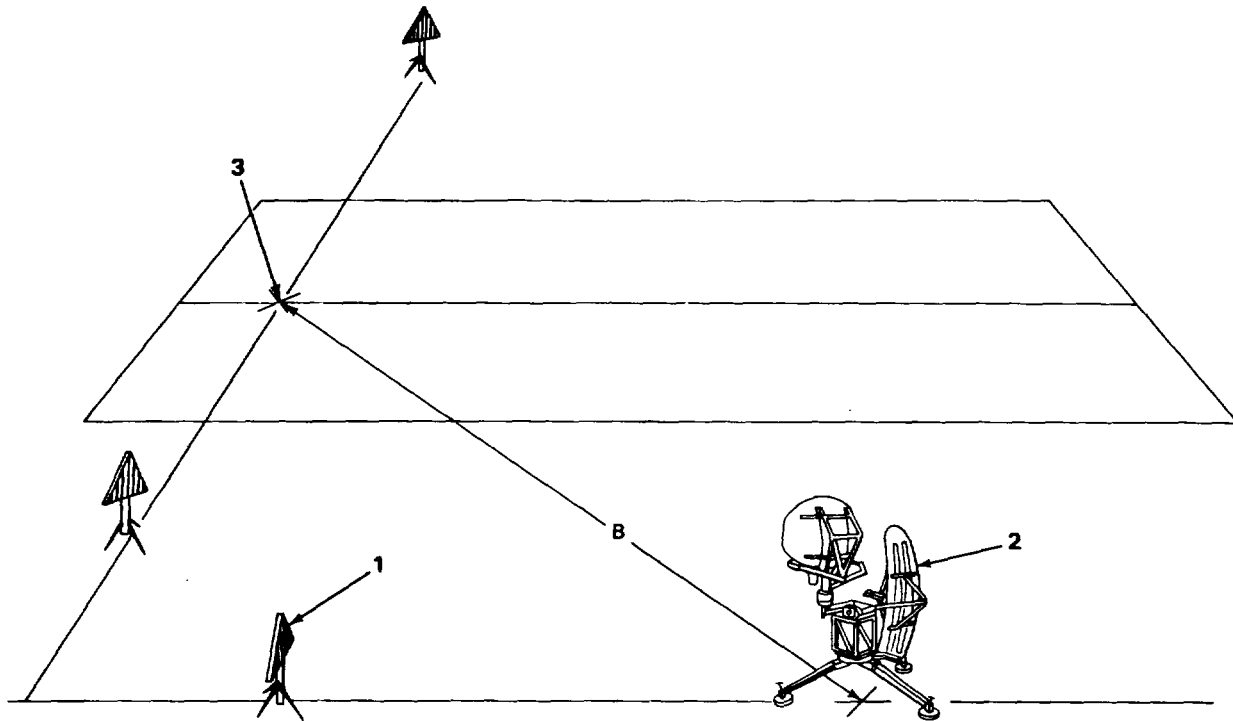

305NE084

18. Position rpl target reflector (1) at point marked in step 17.
19. Determine and record distance to td (B) by measuring a straight line from radar set group (2) to td point (3).

METHOD FOUR

TOOLS REQUIRED: Theodolite or transit
 10-foot stadia rod
 Measuring tape

PERSONNEL REQUIRED: Two

Method four uses two target reflectors for each runway approach, as in method two. This method requires the use of a theodolite, or transit, and stadia rod. It is more precise than method two but requires more time to accomplish.

WARNING

Ensure placement of clr target reflector will not present any safety hazard to departing or approaching aircrafts.

4-26. SITING OF TARGET SIMULATORS. (CONT)

NOTE

Read and become familiar with siting procedure in steps 1 through 21 before attempting to site target simulators.

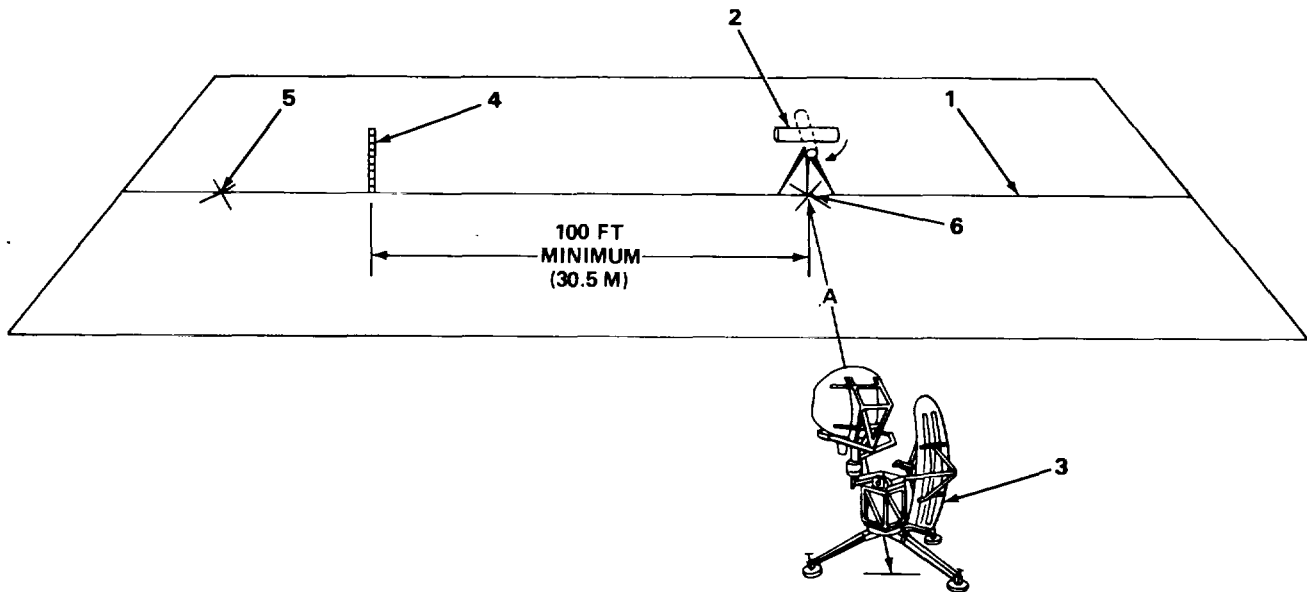

305NE085

1. Determine clr (1) by measuring width of runway and dividing by two.
2. Measure and record the distance of straight line from radar set group (2) to td point (3) (distance A).
3. Set up theodolite (or transit) (4) on clr directly opposite radar set group.
4. Direct second person to hold stadia rod (5) in a vertical position on clr, 100 feet (30.5 m) or more toward td point, facing theodolite.
5. Site vertical crosshair of theodolite on stadia rod. Record azimuth degree Indication at theodolite reference mark.
6. Rotate theodolite 90 degrees in azimuth toward radar set group (2) and lock in azimuth. Check that vertical crosshair is lined up with vertical center of radar set group (2).

NOTE

If crosshair is lined up with vertical center of radar set group proceed with step 7; if not, move theodolite in appropriate direction along clr and repeat procedure, beginning with step 5.

7. Mark point (6) on clr where theodolite is located. Measure the distance from this point to center of radar set group (distance B).

4.26. SITING OF TARGET SIMULATORS. (CONT)

METHOD FOUR (CONT)

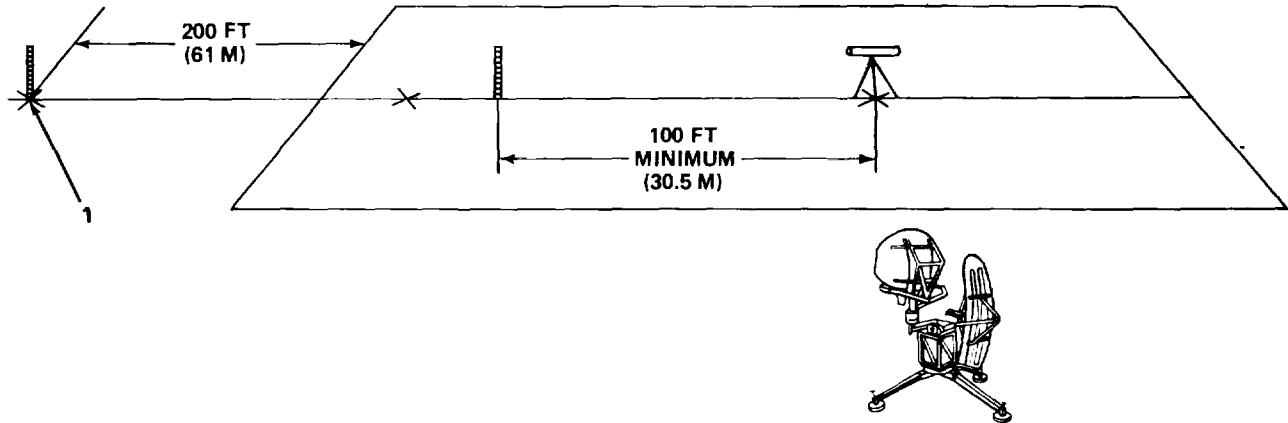

305NEO86

8. Rotate theodolite 90 degrees in azimuth and site vertical crosshair on stadia rod (stadia rod should still be located at position indicated in step 4). Lock in azimuth.
9. Direct second person to move stadia rod along clr 200 feet (61 m) beyond end of runway.
10. Site vertical crosshair of theodolite on stadia rod. If crosshair and stadia rod are not lined up, direct second person to move stadia rod until vertical crosshair and stadia rod are alined. Mark this point (1).

4-26. SITING OF TARGET SIMULATORS. (CONT)

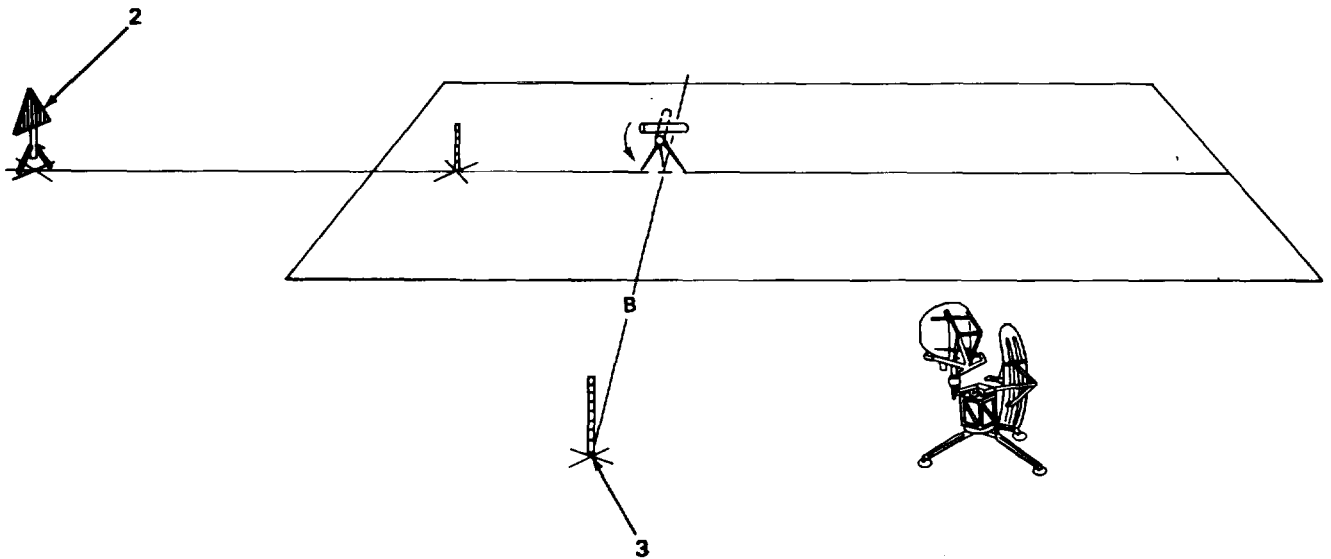

305NE087

11. Position clr target reflector (2) at point marked in step 10.
12. Direct second person to hold stadia rod in vertical position at td point on clr.
13. Set up theodolite on clr approximately midway between radar set group and td point.
14. Site vertical crosshair of theodolite on stadia rod.
15. Rotate theodolite 90 degrees in azimuth toward radar set group side of runway and lock in azimuth.

NOTE

Theodolite is now pointing along a line perpendicular to clr.

16. Direct second person to move stadia rod along this perpendicular line until it is the same distance from clr as that recorded in step 7 (solid line B). Mark this point (3).

4.26. SITING OF TARGET SIMULATORS. (CONT)

METHOD FOUR (CONT)

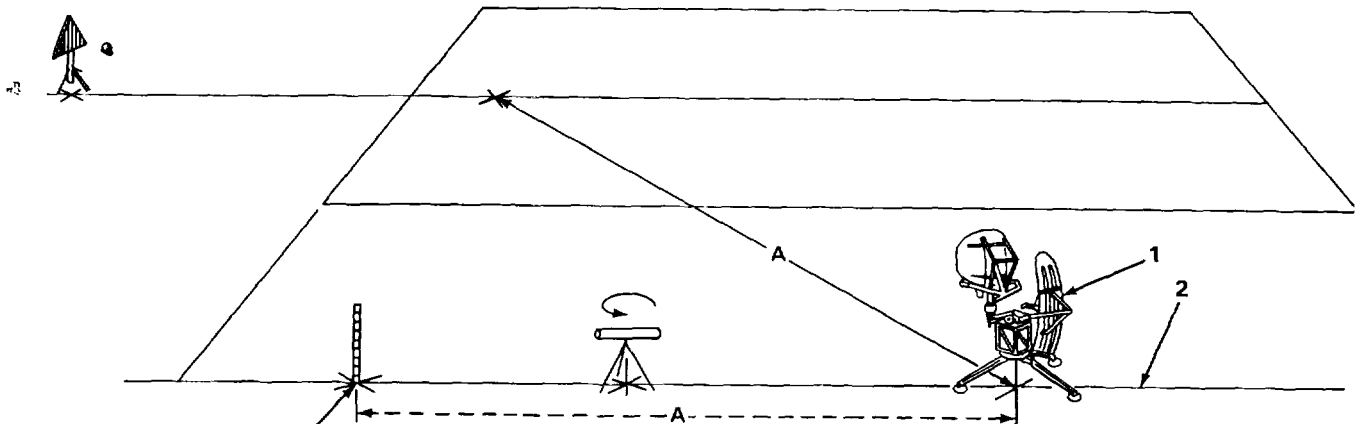

305NE01

17. Set up theodolite at point marked in step 16.
18. Site vertical crosshair of theodolite on vertical center of radar set group (1). Record azimuth degree indication at theodolite reference mark.

NOTE

Theodolite is now pointing along a line parallel to clr. This is the rpl (2).

19. Rotate theodolite 180 degrees from azimuth indication recorded in step 18 and lock in azimuth.

4-26. SITING OF TARGET SIMULATORS. (CONT)

NOTE

This extends rpl away from radar set group past td point.

20. Direct second person to move stadia rod along rpl until it is the same distance from radar set group (dotted line A) as that recorded in step 2 (solid line A) and lined up with vertical crosshair of the theodolite. Mark this point (3).

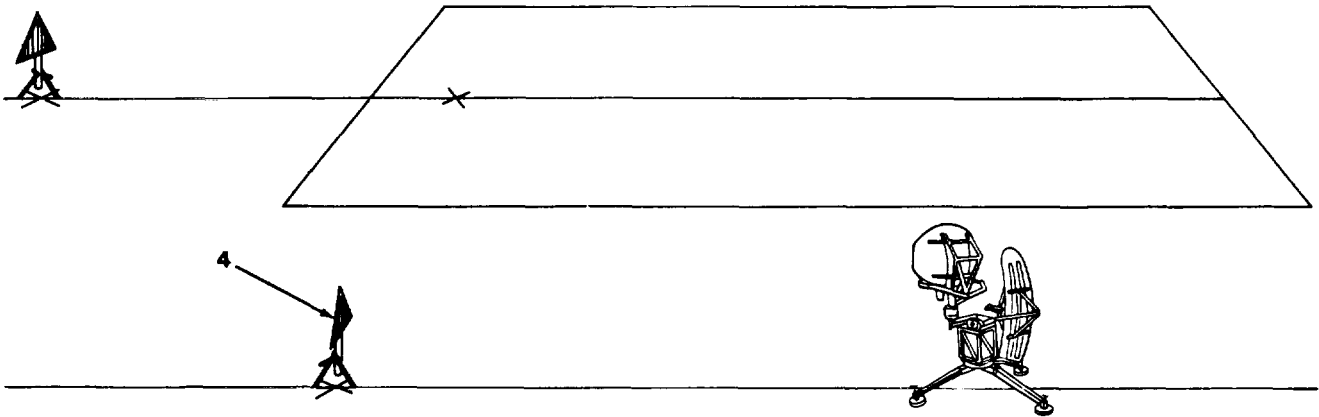

305NE089

21. Position td-rpl target reflector (4) at point marked in step 20.

4-27. PRELIMINARY SERVICING AND ADJUSTMENT.

This paragraph gives procedures for orienting radar set group to runway, checking Installation, checking equipment interlocks, turning on radar set, and checking 10- to 35-degree actuator. Perform procedures below in order listed.

WARNING

This equipment develops lethal voltages; observe safety precautions at all times. Injury or death could result from improper or careless operation.

When power is applied to control indicator and all circuit breakers on receiver-transmitter are off, - 28 v Is still present in local control monitor.

ORIENTATING RADAR SET GROUP

Radar set group must be oriented with runway to which gca landing service is being provided in order for radar display data to be valid. Radar set group orientation consists of physically rotating radar set group on pedestal in order to align antenna scan sectors to runway, thereby ensuring accurate azimuth and elevation data for runway being serviced. Radar set group must be initially oriented, as described in steps 1 through 17, to each runway for which gca landing service is being supplied. Thereafter, to change to a second runway (an approach other than one being serviced) it is only necessary to perform steps 1 through 3. Steps 1 through 3 orient radar set group so 30 sector scan of azimuth antenna is centered on rpl (15 degrees on either side of rpl). Steps 4 through 17 check that orientation of radar set will provide adequate radar coverage, and give instructions for relocating radar set group and/or td point and target simulators, when adequate radar coverage is not present. Although radar set group should be oriented to all approaches being given gca service, only two runways at a time can be serviced without realining one of two preset cursors.

ORIENTATION PROCEDURE**NOTE**

Perform steps 1 through 17 for each approach being serviced from radar site. Once steps 1 through 17 have been accomplished for all runway approaches, it is only necessary to perform steps 1 through 3 when changing runway approaches to orient radar set group to newly selected runway.

1. Mount siting scope on antenna drive siting scope mount (Siting Scope Installation, para 4-20).
2. Loosen, but do not remove, six screws in three strap clamps that secure receiver-transmitter to antenna pedestal.
3. Rotate receiver-transmitter until vertical crosshair of siting scope is lined up with center of rpl target reflector. Tighten six screws loosened in step 2.
4. Remove siting scope from antenna drive siting scope mount and install it on azimuth antenna siting scope mount (Siting Scope Installation, para 4-20).
5. Manually rotate azimuth antenna toward runway until 14-degree mark is indicated on azimuth scan protractor.

4-27. PRELIMINARY SERVICING AND ADJUSTMENT. (CONT)

6. Site through siting scope and slowly rotate azimuth antenna toward 0-degree mark on azimuth protractor. Be sure that furthest td bracketing reflector or runway clr reflector (whichever is used) and td point are within the 14- to 0-degree scan area. Radar set group is now oriented to runway for operation with azimuth precision scan of 15 degrees left to 15 degrees right of rpl.

NOTE

If the conditions in step 6 cannot be met, or if an azimuth scan other than 15 degrees left to 15 degrees right of rpl is required, perform steps 7 through 14 to offset scan.

7. Manually rotate azimuth antenna toward runway until 14-degree mark is indicated on azimuth protractor.
8. Loosen, but do not remove, six screws in three strap clamps that secure receiver-transmitter to antenna pedestal.
9. Rotate receiver-transmitter until vertical crosshair of siting scope is centered on td bracketing reflector furthest from radar set group. If clr target reflector is used instead of bracketing target reflector, direct second person to hold stadia rod in vertical position on td point. Rotate receiver-transmitter until vertical crosshair of siting scope is lined up with stadia rod.
10. Tighten six screws loosened in step 8.
11. Manually rotate azimuth antenna until vertical crosshair of siting scope is centered on rpl target reflector.
12. Verify that indication on azimuth scan protractor is 10 degrees or less.

NOTE

If indication on azimuth protractor is 10 degrees or less, skip steps 13 through 16 and proceed to step 17. If azimuth protractor indication is greater than 10 degrees, perform any one or more of steps 13 through 16 below and repeat this procedure, beginning with step 7.

13. Relocate bracketing td reflectors closer to runway. Do not place closer than 75 feet (22.9 m) from clr.
14. Move radar set group further back from td point along rpl.

NOTE

If step 15 below is performed, td bracketing reflectors also must be moved to bracket td point.

15. Move td point closer to approach end of runway (away from radar set group). Do not relocate closer than 775 feet (236 m) from end of runway.
16. Reposition radar set closer to clr. Do not place closer than 100 feet (31 m) from clr.
17. Remove siting scope and store in transmitter door.

4-27. PRELIMINARY SERVICING AND ADJUSTMENT. (CONT)

CHECKING INSTALLATION

Perform the following equipment checks after radar set has been Installed and oriented to runway but prior to initial application of power.

Interconnecting Cables and Connections

Check all interconnecting cables on receiver-transmitter at radar site and on control-indicators at operating site and ensure that all connections are secure. Compare with FO-1 for correct and complete interunit cabling.

Waveguides

Inspect all waveguides on radar set group for tightness and correct fit.

Azimuth Antenna Drive

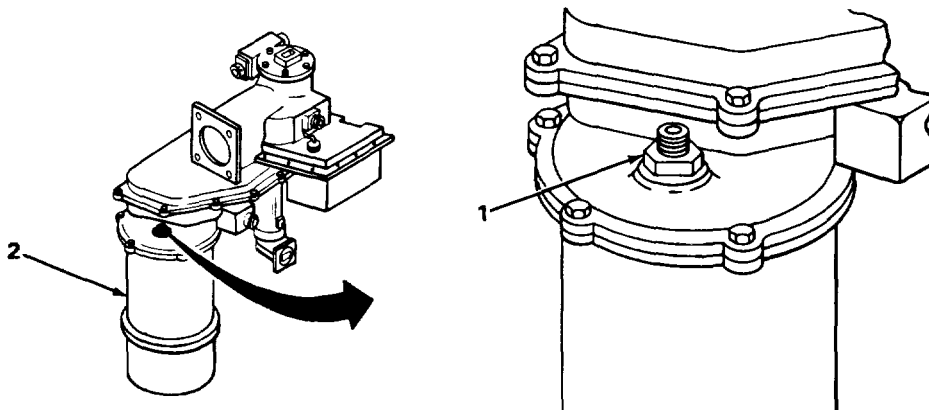

305NE110

1. Check filler plug (1) on azimuth antenna drive and make sure ventholes are outside (open).
2. Check that red protective cover (2) on bottom of azimuth antenna drive is removed.

Elevation Antenna Drive

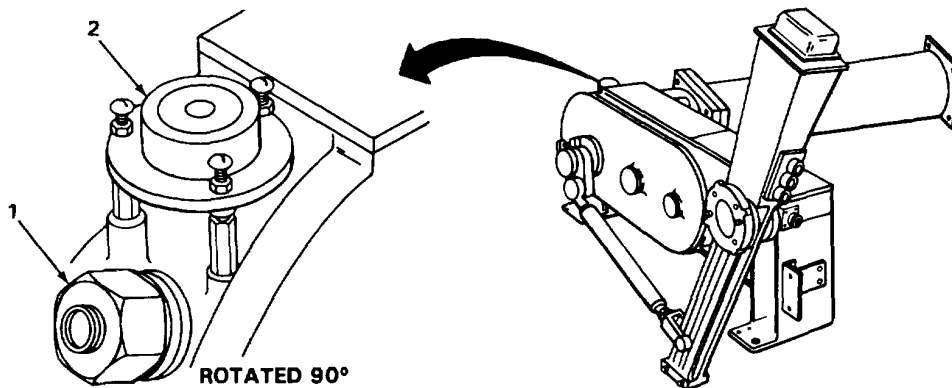

305NE111

1. Check filler plug (1) on elevation antenna drive and make sure ventholes are outside (open).
2. Check bubble level (2) on elevation antenna drive and ensure radar set group is level.

4-27. PRELIMINARY SERVICING AND ADJUSTMENT. (CONT)

Dehydrator Cartridges

Check three adapters in waveguides to ensure that dehydrator cartridges are installed in each adapter. See paragraph 3-5 for location of dehydrator cartridges and adapters.

Antenna Pedestal Earth Anchors

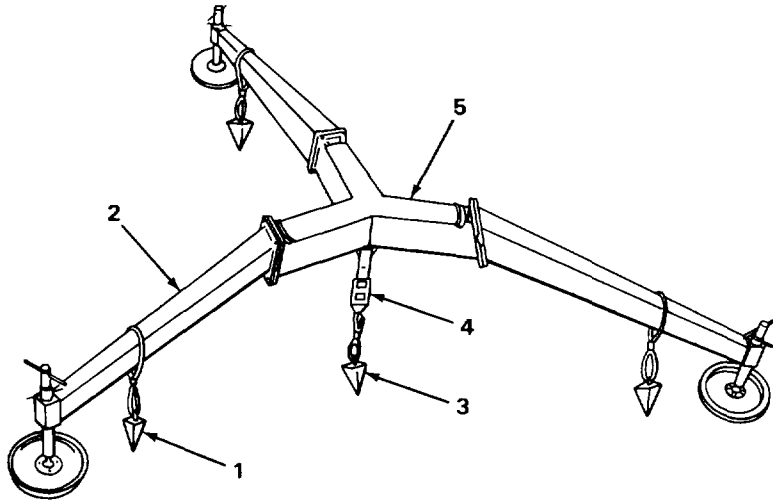

305NE112

Inspect three earth anchors (1) securing three leg assemblies (2), and one earth anchor (3) and strap ratchet (4) securing center section (5). Make sure they are tight and secure.

Azimuth Antenna and Servo Actuator

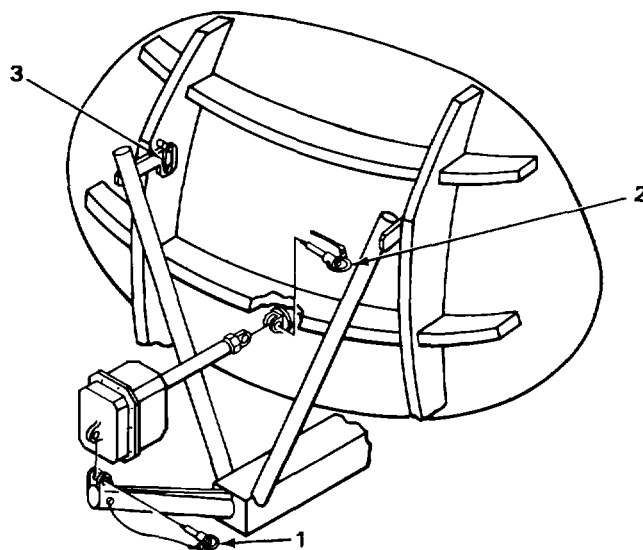

305NE220

Manually rotate azimuth antenna through its 360-degree scan. Observe that there are no restrictions to movement or unusual noises. Check two pins (1 and 2) in servo actuator and ensure they are secure. Check that antenna latches (3) on azimuth antenna are secure.

4-27. PRELIMINARY SERVICING AND ADJUSTMENT. (CONT)

CHECKING INSTALLATION (CONT)

Elevation Antenna and Servo Actuator

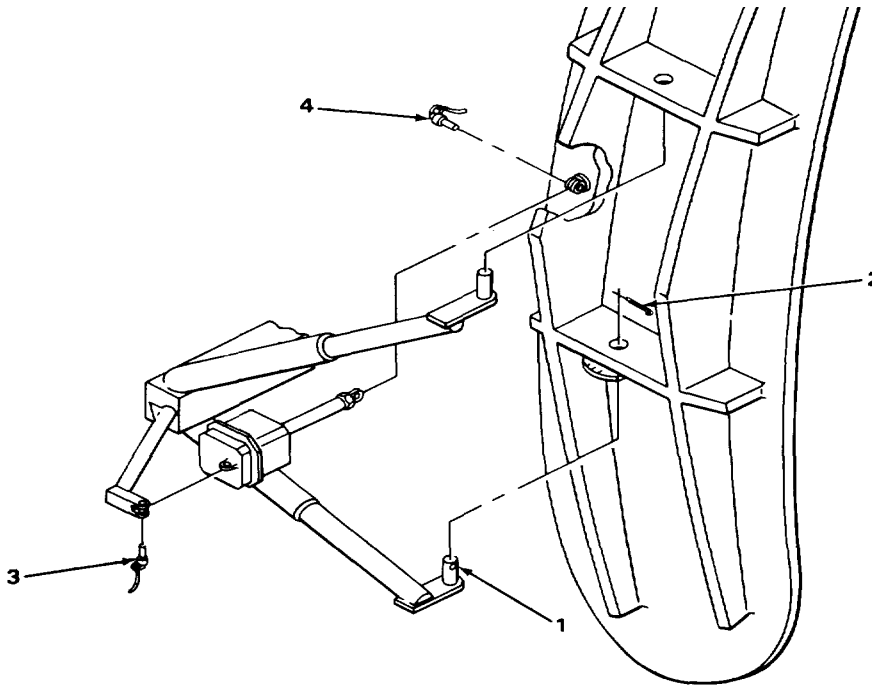

305NE221

Check lower elevation support pin (1) and make sure clip (2) is installed. Manually rotate elevation antenna through its entire scan cycle by either turning knurled end of motor shaft or pushing on actuator arm crank (on left side of elevation antenna drive). Observe that there are no restrictions to movements or unusual noises. Check two pins (3 and 4) in servo actuator and ensure they are secure.

Control-Indicators

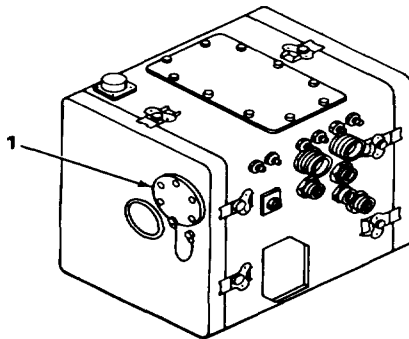

305NE218

Verify that red ventilation covers (1) on back of both control-indicators (master and slave) are removed.

4-27. PRELIMINARY SERVICING AND ADJUSTMENT. (CONT)

Receiver-Transmitter

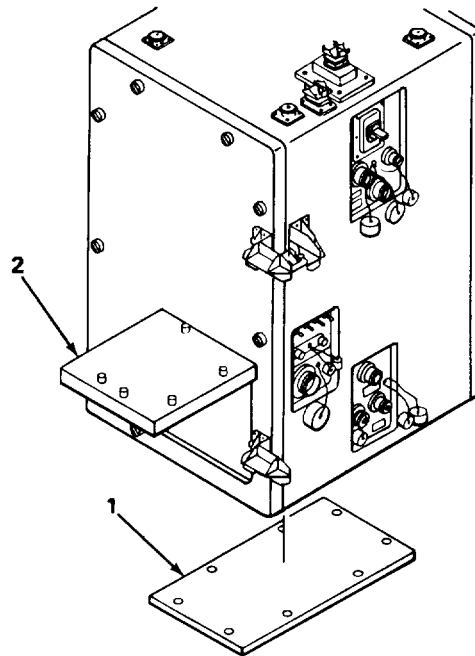

305NE219

Verify that red vent cover (1) on bottom of receiver-transmitter has been removed. Check that filter hood (2) on receiver side of receiver-transmitter is open.

EQUIPMENT INTERLOCKS

Two Interlock circuits within receiver-transmitter and one within each control-indicator are provided to prevent incorrect or hazardous operation of equipment. Equipment interlocks and their functions are described below.

Control-indicators

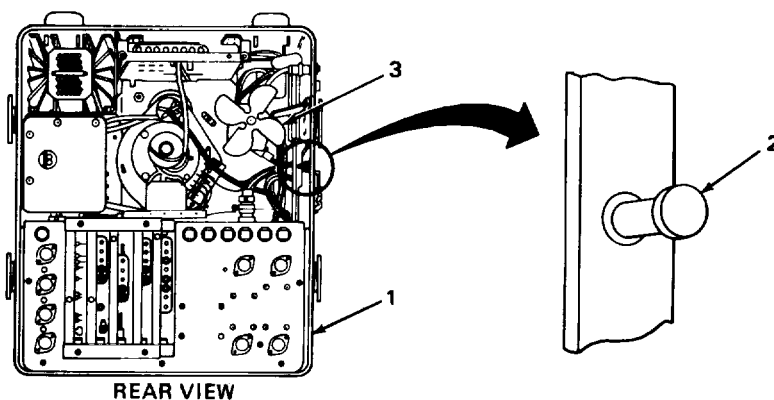

305NE113

Each control-indicator (1) contains S607 BLOWER INTLK (2), which is activated by removal of rear cover of control-indicator. S607 BLOWER INTLK is an Interlock switch in series with blower motor winding. When rear cover is removed from control-indicator, phase B and phase C of primary power to blower (3) are removed and blower does not operate. Make sure rear cover of control-indicator is firmly secured so interlock will not prevent operation of blower when power is applied.

4-27. PRELIMINARY SERVICING AND ADJUSTMENT. (CONT)

Receiver-Transmitter

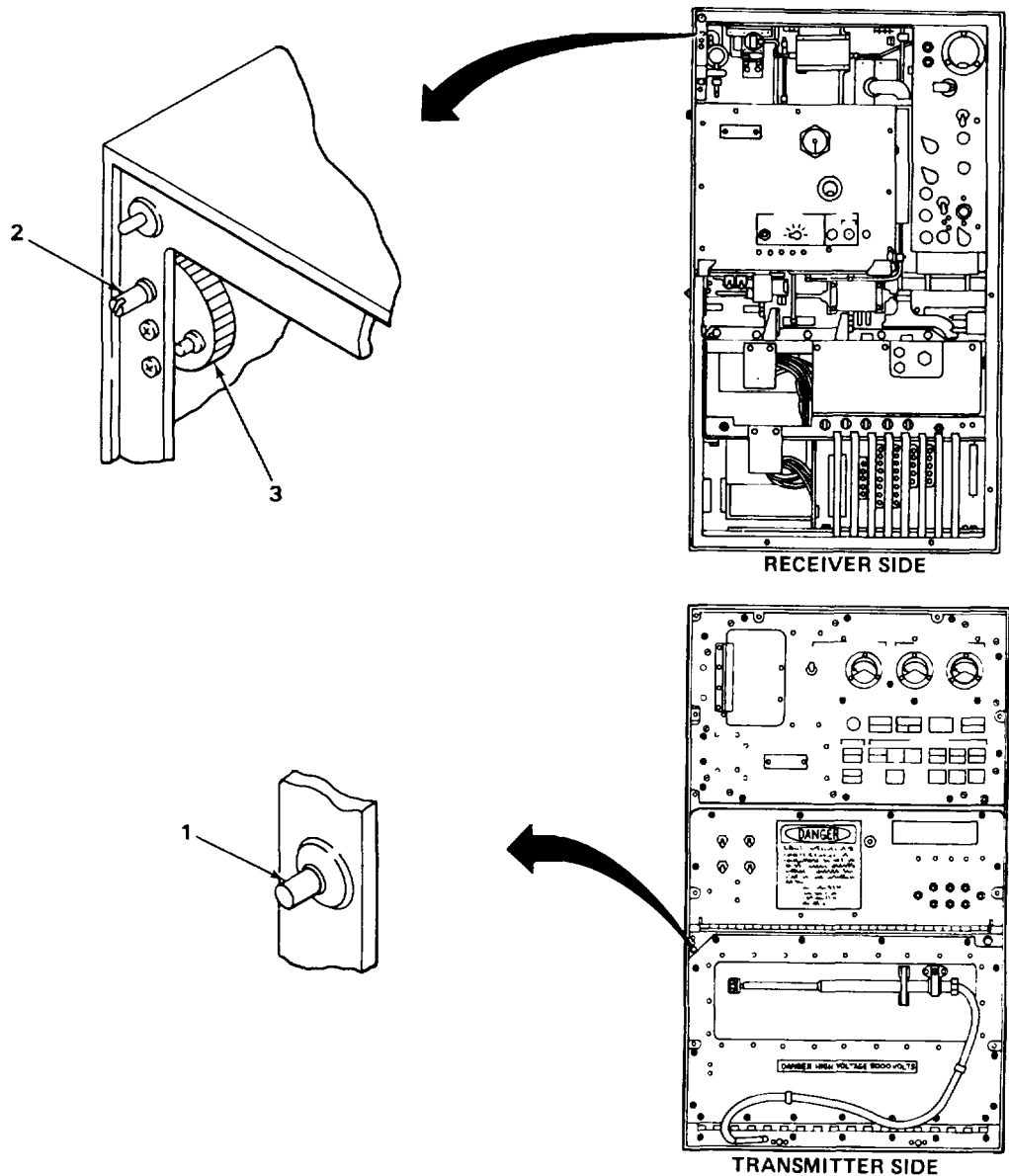

305NE114

Two interlock circuits are located in receiver-transmitter. The first circuit contains two interlock switches that are activated by closing of receiver and transmitter doors. They are designated S105 XMTR INTLK (1), which is located on transmitter, and S106 RCVR INTLK (2), which is located on receiver. These two interlocks are in series with DS2 WARNING BUZZER (3) and LOCAL/REMOTE switch located in local control monitor. When LOCAL/REMOTE switch is placed in RT position (local mode of operation) and receiver and transmitter doors are closed, DS2 WARNING BUZZER will sound alerting personnel that receiver-transmitter has been left in local mode of operation. Ensure LOCAL/REMOTE switch is returned to IND position before closing receiver and transmitter doors.

4-27. PRELIMINARY SERVICING AND ADJUSTMENT. (CONT)

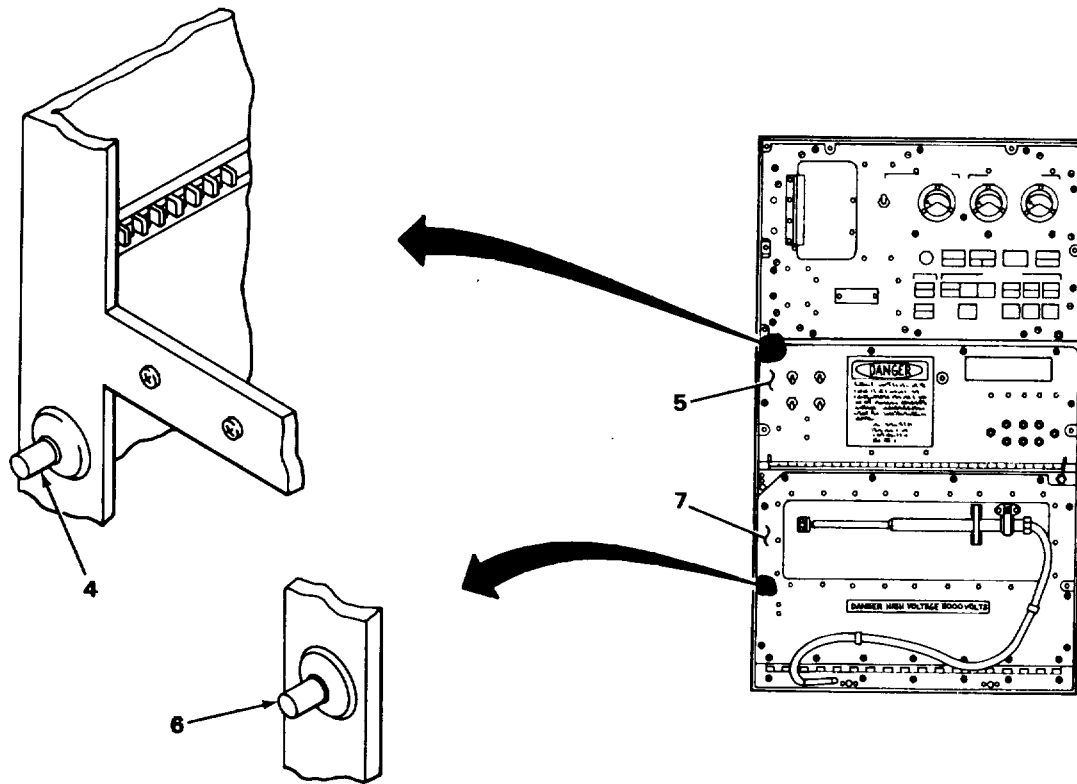

305NE115

The second interlock circuit also contains two interlock switches. S109 DOOR CLOSED TOP (4) is activated when TRANSMITTER PANEL (5) is open. S110 DOOR CLOSED BOTTOM (6) is activated when SCR ACCESS PANEL (7) is open. Both these interlock switches are in series with high-voltage Interlock signal. When either TRANSMITTER PANEL or SCR ACCESS PANEL is open, interlock circuit is disabled and high voltage is shut off. Ensure TRANSMITTER PANEL and SCR ACCESS PANEL are closed and secured prior to power application so that high voltage required by receiver-transmitter will be available.

INITIAL TURN-ON PROCEDURE

NOTE

See paragraphs 2-4 and 2-5 for Initial adjustments and turn-on procedures for radar set.

4-27. PRELIMINARY SERVICING AND ADJUSTMENT. (CONT)

INITIAL TURN-ON PROCEDURE (CONT)

NOTE

The remaining Preliminary Services and Adjustments should be performed by organizational maintenance personnel.

CHECKING THE 10- TO 35-DEGREE ACTUATOR

The 10- to 35-degree actuator is checked after initial turn-on procedure has been accomplished. The check is performed using clinometer supplied as part of radar set. If unfamiliar with use of clinometer, see Ground Angle Determination Using Clinometer (para 4-25). Perform 10- to 35-degree actuator check as indicated below.

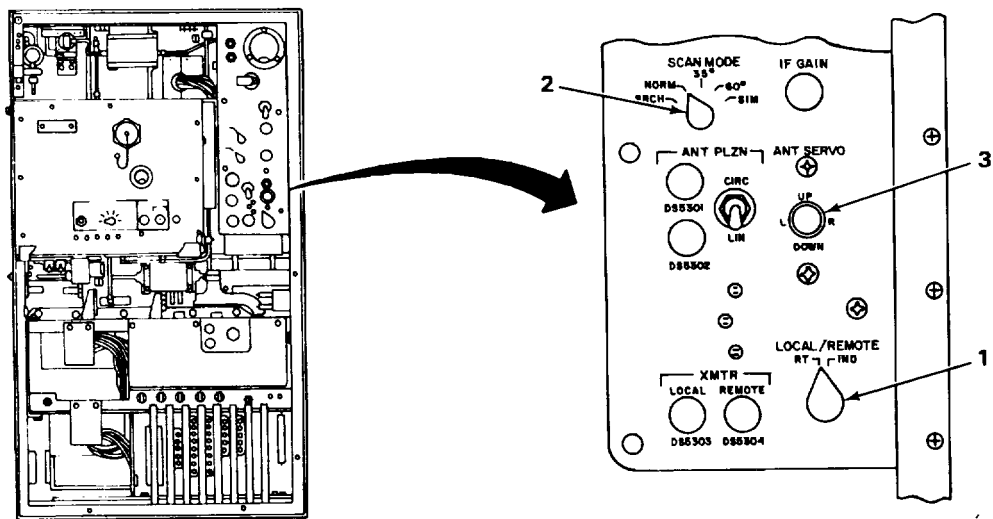

305NE116

NOTE

See paragraphs 2-1 and 4-34 for location and description of operator and organizational controls.

1. On LOCAL CONTROL-MONITOR place LOCAL/REMOTE switch (1) to RT position and SCAN MODE switch (2) to NORM position.
2. Using ANT SERVO control (3), servo elevation antenna until zero degrees is indicated on elevation antenna scan protractor.
3. Check bubble level on top of elevation antenna drive to ensure radar set group is level. If necessary, level radar set group. See Radar Set Assembly and Installation (para 4-7).
4. Attach clinometer on elevation antenna clinometer mount. See Clinometer Installation (para 4-21).

4-27. PRELIMINARY SERVICING AND ADJUSTMENT. (CONT)

5. Manually tilt elevation antenna to top dead center of scan and adjust clinometer to indicate 20.6 degrees. Verify that clinometer bubble is centered.

NOTE

If clinometer bubble is not centered, perform step 6. If bubble is centered, skip step 6 and proceed to step 7.

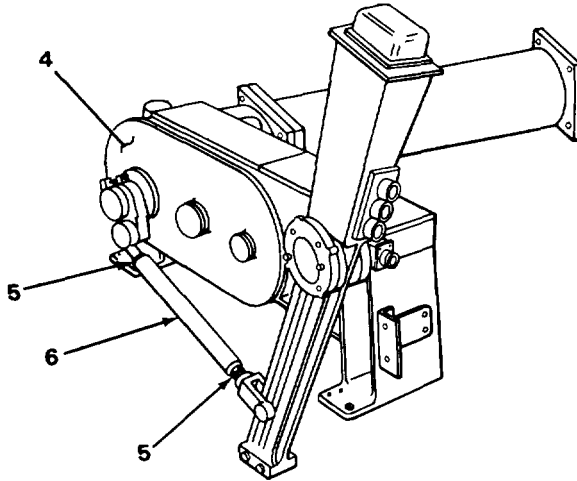

305NE117

6. On elevation antenna drive (4), loosen two locknuts (5) and adjust length of elevation antenna shaft (6) until clinometer bubble level is centered. Tighten two locknuts, making sure clinometer bubble remains centered.

NOTE

If adjustment in step 6 cannot be accomplished, refer to higher category of maintenance for complete realignment of 10- to 35-degree actuator.

7. Remove clinometer from elevation antenna clinometer mount and store in transmitter door. **INSTALLING PRESELECTOR FILTERS**

Preselector filters are checked after Initial turn-on procedure has been performed. Before checking preselector filters, the assigned transmitter frequency must be obtained. Refer to current local standard operating procedures (SOP) to obtain the assigned transmitter frequency. This procedure requires two personnel: one person is stationed at control-indicator site and the other at receiver-transmitter site. Headsets are connected to HEADSET jack on pulse generator and INTERCOM jack on receiver to provide communication between personnel. Echo Box TS-488()/UP is needed to adjust transmitter frequency once proper preselector filters have been installed.

4-27. PRELIMINARY SERVICING AND ADJUSTMENT. (CONT)

INSTALLING PRESELECTOR FILTERS (CONT)

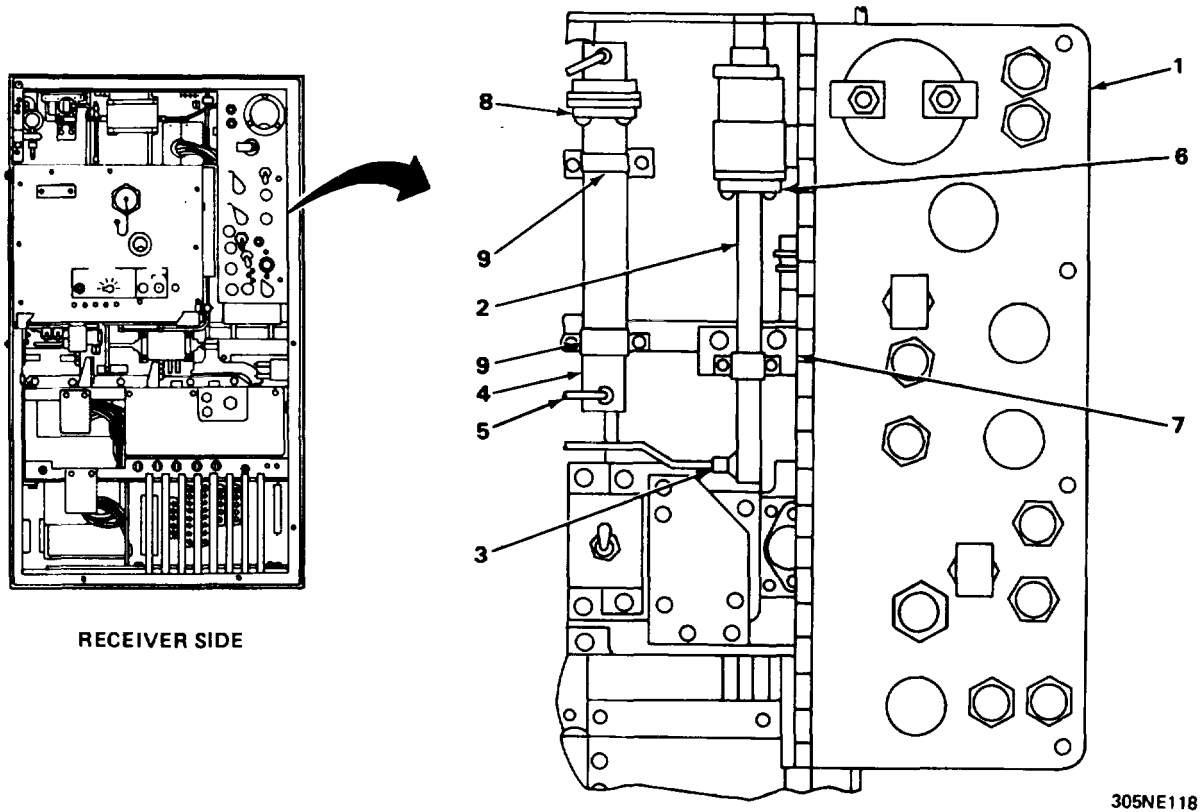

1. Open CONTROL-MONITOR, LOCAL panel (1) and locate preselector filter FL5 (2) on FL5 WAVEGUIDE (3) and preselector filter FL6 (4) on FL6 WAVEGUIDE (5).
2. Using table below, check that frequency range of filters FL5 and FL6 correspond to assigned transmitter frequency.

| TRANSMITTER FREQUENCY | PRESELECTOR FILTER |
|-----------------------|--------------------|
| 9000 to 9200 MHz | 139966-1 (2 each) |
| 9200 to 9400 MHz | 139966-2 (2 each) |
| 9400 to 9600 MHz | 139966-3 (2 each) |

NOTE

If correct preselector filters are already installed, skip steps 3 through 34 and perform step 35. If proper filters are not already installed, proceed with step 3 below.

3. Direct second person to tilt azimuth antenna using ANTENNA control located on master control Indicator until AZIMUTH/BITE meter Indicates zero degrees. Set the following controls to positions Indicated.

4-27. PRELIMINARY SERVICING AND ADJUSTMENT. (CONT)

| CONTROL | POSITION |
|-------------|------------------------|
| LO TUNE | Midrange |
| FTC | OFF |
| TRANSMITTER | OFF |
| STC | OFF |
| VIDEO GAIN | fully counterclockwise |
| POWER | OFF |

4. Direct second person to set following controls on pulse generator to positions indicated.

| CONTROL | POSITION |
|-------------|----------|
| RANGE MILES | 5 |
| SCAN | OFF |
| SCAN MODE | SEARCH |

5. On transmitter control panel, set all four switches to OFF.
 6. On transmitter control-indicator, press CONTROL LOCAL/REMOTE switch to indicate LOCAL.
 7. On local control monitor, place controls below to positions indicated.

| CONTROL | POSITION |
|-------------|----------|
| LOCAUREMOTE | RT |
| SCAN MODE | SRCH |
| ANT PLZN | LIN |
| FTC | OFF |
| STC | OFF |
| IF GAIN | Midrange |

8. On receiver-transmitter main power panel, set all four switches to OFF.
 9. On receiver, adjust R11 LINEAR GAIN control fully clockwise and R8 LO TUNE ADJ control to midrange position.
 10. Carefully disconnect waveguides (3 and 5) from their respective filters (2 and 4) by loosening two waveguide plug connectors.
 11. Remove filter FL5 (2) by removing four screws, flat washers, and lockwashers from FL5 flange (6), and two screws, flat washers, and lockwashers from clamp (7). Retain hardware for reinstallation.
 12. Remove filter FL6 (4) by removing four screws, flat washers, and lockwashers from FL6 flange (8), and four screws, flat washers, and lockwashers securing two clamps (9). Retain hardware for reinstallation.
 13. Install appropriate replacement filters on waveguides. Installation is reverse of removal procedure in steps 10 through 12.

4-27. PRELIMINARY SERVICING AND ADJUSTMENT. (CONT)**INSTALLING PRESELECTOR FILTERS (CONT)**

14. On receiver-transmitter main power panel, place MAIN POWER and HV switches to ON.
15. On transmitter control panel, place all four switches to ON.

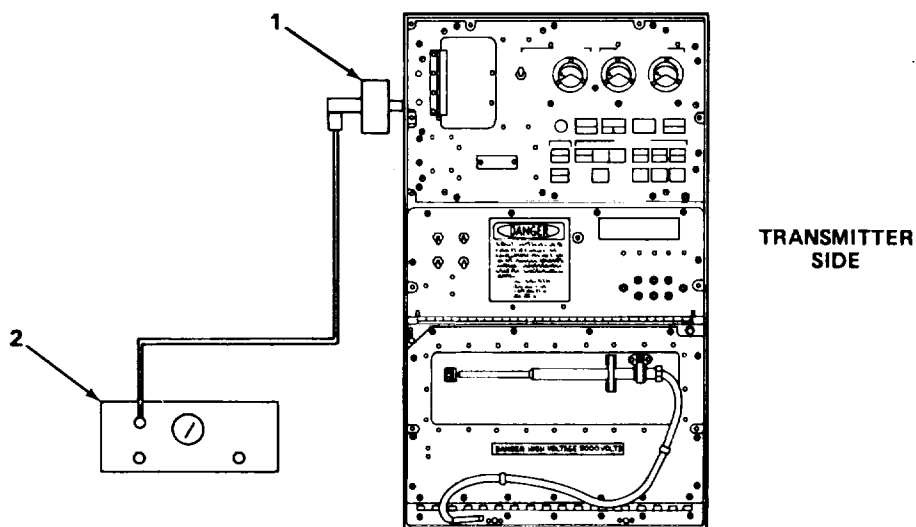

305NE119

16. On receiver-transmitter, disconnect flexible waveguide from azimuth directional coupler (1) and connect Echo Box TS-488()/UP (2) to azimuth directional coupler.
17. Dial In assigned transmitter frequency on echo box.
18. On transmitter control-indicator, press HV READY-HV ON switch to light HV ON and wait 5 to 7 minutes to allow magnetron to settle.
19. Adjust TUNING control on echo box for maximum deflection ring time on echo box meter.
20. Direct second person to place POWER circuit breaker on control-indicator to ON.
21. Direct second person to adjust FOCUS and INTENSITY controls on control-indicator until a faint but discernible sweep is visible on crt.
22. On receiver, rotate LOCAL OSC ADJ control (usually painted red) until maximum ring time is observed on crt at control-indicator site (rotating LOCAL OSC ADJ control clockwise increases frequency of local oscillator, counterclockwise rotation decreases frequency).
23. On receiver, press and hold LO TUNE REMOTE/LOCAL switch and adjust LO TUNE adjust control until maximum ring time is observed on crt at control-indicator site.
24. On local control monitor, set LOCAL/REMOTE switch to IND position.
25. On transmitter control-indicator, press CONTROL switch to light REMOTE.
26. Remove headset from INTERCOM jack on receiver.
27. Close and lock receiver and transmitter doors.

4-27. PRELIMINARY SERVICING AND ADJUSTMENT. (CONT)

28. Disconnect echo box from azimuth directional coupler and reinstall flexible waveguide on azimuth directional coupler.

WARNING

To prevent being hit by scanning antennas, ensure SCAN switch on control-indicator is in OFF position before performing step 29.

29. On receiver-transmitter main power panel, place SCAN switch to ON. Proceed to control-indicator site.

WARNING

To prevent exposure to hazardous rf radiation, ensure no personnel are within an 80-foot (24.5 m) radius of azimuth antenna before performing step 30.

30. Place SCAN switch on control-indicator to ON.
31. On control-indicator, place TRANSMITTER switch through RESET to WIDE PLS position and observe radar target returns on crt.
32. Stop antenna scan on a known radar return by placing SCAN switch on control-indicator to OFF.
33. Adjust LO TUNE control-indicator for maximum return echo.
34. Place SCAN and TRANSMITTER switches to OFF.
35. Remove headset from HEADSET jack on pulse generator.

AZ TILT/BITE METER ALINEMENT

AZ TILT/BITE meter indicates tilt angle (- 1 degree to + 25 degree) of azimuth antenna. AZ TILT/BITE meter alinement procedure requires two personnel; one at radar site and one at control-indicator site. Perform the following procedure to aline AZ TILT/BITE meter.

NOTE

The AZ TILT/BITE meter alinement procedure must be performed for each control-indicator. Unless otherwise indicated, perform the following steps only on control-indicator or pulse generator whose AZ TILT/BITE meter is being alined.

1. Ensure all controls and switches are in positions indicated in Preliminary Operating Procedures (para 2-5).
2. On master control-indicator, ensure BITE-AZ TILT switch is in AZ TILT position.
3. Attach clinometer to azimuth antenna clinometer mount. See Clinometer Installation
4. Adjust clinometer to - 1 degree and tilt azimuth antenna, using ANTENNA switch, until clinometer bubble indicates level.

4.27. PRELIMINARY SERVICING AND ADJUSTMENT. (CONT)**AZ TILT/BITE METER ALINEMENT (CONT)**

5. On AZ-EL blanking pulse generator card, adjust R36 METER ZERO control for - 1 degree indication on AZ TILT/BITE meter.
6. Using ANTENNA switch, adjust clinometer to indicate + 20 degrees and tilt azimuth antenna until clinometer bubble indicates level.
7. On AZ-EL blanking pulse generator cord, adjust R36 METER ZERO control for + 20 degree indication on AZ TILT/BITE meter.
8. Place BITE-AZ TILT switch on control-indicator to BITE position.
9. Set multimeter to measure + 5 v. Connect negative lead of multimeter to J616 DC RET and positive lead to J615 BITE MON on control indicator front panel.
10. Place BITE SELECT switch to CALIBRATE position.

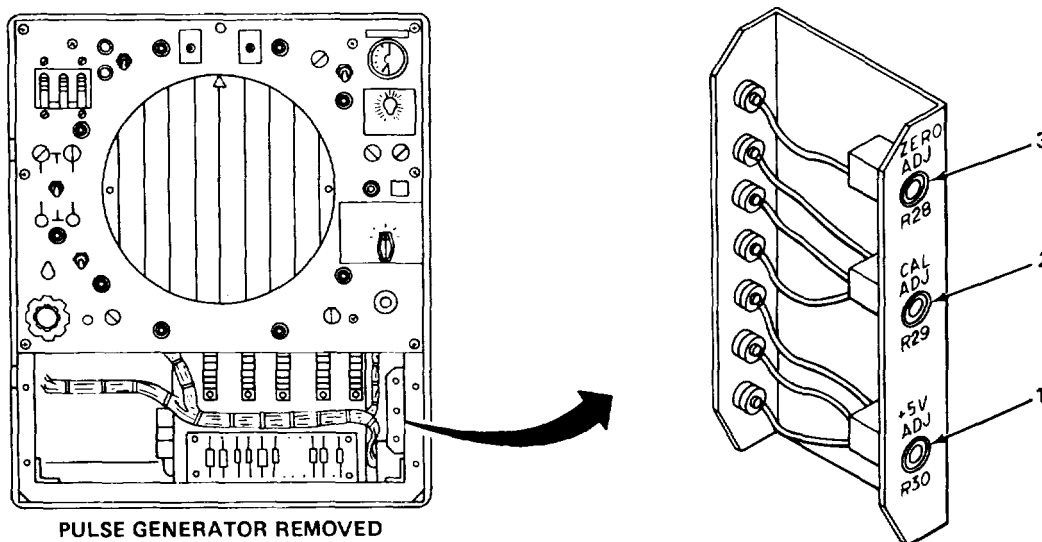
**CAUTION**

Make sure adequate support is available so pulse generator does not fall when being pulled out of control-indicator.

11. Pull pulse generator out of control-indicator until R30 + 5V ADJ (1) is accessible. Adjust R30 for multimeter Indication of + 5 v.
12. Adjust R29 CAL ADJ (2) for full-scale AZ TILT/BITE meter indication.
13. Place BITE SELECT switch to ZERO position.
14. Adjust R28 ZERO ADJ (3) for exact center scale AZ TILT/BITE meter indication.
15. If necessary, repeat steps 12 through 14 to obtain full-scale and center-scale AZ TILT/BITE meter Indications.
16. Disconnect multimeter leads, reinstall pulse generator, allowing access to top deck controls. Place BITE-AZ TILT switch to AZ TILT position.

4-27. PRELIMINARY SERVICING AND ADJUSTMENT. (CONT)**AZIMUTH TILT BLANKING ALINEMENT**

A 3-degree section of range marks on the elevation display is blanked to represent tilt position of azimuth antenna during the precision mode of operation. This blanked section must be properly oriented on elevation display in order for azimuth antenna tilt information to be accurate. Azimuth tilt blanking alinement requires two personnel: one at radar site and one at control-indicator site. Perform azimuth tilt blanking alinement as follows.

NOTE

Azimuth tilt blanking alinement procedure must be performed for each control- Indicator. Unless otherwise indicated, perform the following steps only on control- Indicator on which azimuth tilt blanking alinement is being performed.

1. Ensure all controls and switches are in positions indicated in Preliminary Operating Procedure (para 2-5).
2. On pulse generator, place RANGE MILES switch to position 40.
3. At radar site, adjust clinometer to indicate + 3 degrees and tilt azimuth antenna using ANTENNA switch until clinometer bubble indicates level.
4. Remove clinometer from azimuth antenna clinometer mount and install on elevation antenna clinometer mount. See Clinometer Installation (para 4-21).
5. Adjust clinometer to indicate + 3 degrees, then manually rotate elevation antenna until clinometer bubble indicates level.
6. On pulse generator, alternately place ANGLE VOLTS switch to EL and OPERATE positions. Adjust ART ANGLE V control so artificial sweep trace coincides with operate sweep trace on elevation display. Record ART ANGLE V control dial indication.

WARNING

To prevent being hit by scanning antennas, ensure antenna scan area is clear of personnel before performing step 7.

7. On master pulse generator, place SCAN switch to ON position.
8. On pulse generator, set ART ANGLE V control dial to indicate 30 divisions more than indication recorded In step 6.

NOTE

ART ANGLE V control is now set to produce a 4.5-degree artificial sweep trace.

9. Alternately place ANGLE VOLTS switch in edge EL and OPERATE positions. Adjust R31 AZ TILT POS control so top of blanked range mark section coincides with 4.5-degree artificial sweep
10. On pulse generator, set ART ANGLE V control dial to indicate 30 divisions less than indication recorded in step 6.

NOTE

ART ANGLE V control is now set to produce a 1.5-degree artificial sweep trace.

4-27. PRELIMINARY SERVICING AND ADJUSTMENT. (CONT)**AZIMUTH TILT BLANKING ALINEMENT (CONT)**

11. Alternately place ANGLE VOLTS switch in EL and OPERATE positions. Adjust R37 AZ WIDTH control so top of blanked range mark section coincides with 1.5-degree artificial sweep trace.
12. Place SCAN switch on master pulse generator to OFF position.
13. Remove clinometer from elevation antenna clinometer mount and store in receiver door.

ELEVATION SERVO BLANKING ALINEMENT

A 3-degree section of range marks on azimuth display is blanked to indicate servo position of elevation antenna during the precision mode of operation. This blanked section must be properly oriented on azimuth display in order for elevation antenna servo data to be accurate. The elevation servo blanking alinement requires two persons: one at radar site and one at control-indicator site. Perform elevation servo blanking alinement as follows.

NOTE

Elevation servo blanking alinement procedure must be performed for each control- indicator. Unless otherwise indicated, perform the following steps only on control-indicator on which elevation servo blanking alinement is being performed.

1. Ensure all controls and switches are in positions indicated in Preliminary Operating Procedure (para 2-5).
2. On pulse generator, place RANGE MILES switch to position 40.
3. Use ANTENNA control on master control-indicator to servo elevation antenna to zero degrees as indicated on elevation antenna protractor.
4. At radar site, manually rotate azimuth antenna to a scan angle of zero degrees as indicated on elevation protractor on azimuth antenna drive.
5. Alternately place ANGLE VOLTS switch on pulse generator in AZ and OPERATE positions. Adjust ART ANGLE V control so artificial sweep trace coincides with operate sweep on azimuth display. Record ART ANGLE V control dial indication.
6. Place SCAN switch on master pulse generator to ON position.

WARNING

To prevent being hit by scanning antennas, ensure personnel are clear of antenna scan area before performing step 7.

7. Set ART ANGLE V control dial to indicate 15 divisions more than indication recorded in step 5.

NOTE

ART ANGLE V control dial is now set to produce a 1.5-degree artificial sweep trace.

8. Alternately place ANGLE VOLTS switch in AZ and OPERATE positions. Adjust R22 EL SERVO POS control on AZ-EL blanking pulse generator cards so top edge of blanked range mark section coincides with 1.5-degree artificial sweep trace.

4-27. PRELIMINARY SERVICING AND ADJUSTMENT. (CONT)

9. Set ART ANGLE V control on pulse generator to indicate 15 divisions less than indication recorded in step 5.

NOTE

ART ANGLE V control is now set to produce a - 1.5 degree artificial sweep trace.

10. Alternately place ANGLE VOLTS switch in AZ and OPERATE positions. Adjust R38 EL WIDTH control on AZ-EL blanking pulse generator card so bottom edge of blanked rangemark section coincides with - 1.5 degree artificial sweep trace.
11. Ensure ANGLE VOLTS switch is returned to OPERATE position.

4-28. CIRCUIT ALINEMENT.

This paragraph contains procedures for locating target simulators on radar display; performing precision display adjustments; alining azimuth, elevation, and height finder cursors; and adjusting and orientating ppi display. After target simulators are located on radar display, three cursors (azimuth, elevation, and height finder) are alined by comparison with two points of intercept which are represented by predetermined settings of ART ANGLE V control. The settings of ART ANGLE V control are determined by azimuth offset angle, elevation ground angle, and elevation alinement angle. These angles are determined before the actual cursor alinements. Lastly, ppi display is oriented to airfield using azimuth range and bearings of three fixed targets. Prior to performing circuit alinements, obtain the following data to avoid delays:

Field elevation
Runway headings
Glide scope angle
Azimuth range and bearings of three fixed targets.

PRECISION DISPLAY ADJUSTMENTS**NOTE**

Unless otherwise indicated, perform the following steps on control-indicator where precision display adjustments are being performed.

1. On both pulse generators, place SCAN MODE switch to NORM position.
2. On master pulse generator, place SCAN switch to OFF position.
3. On control-indicator, turn navigational grid on display so grid lines are horizontal.
4. On pulse generator, place ANGLE VOLTS switch to AZ position. Adjust ART ANGLE V control to position artificial sweep directly under center grid line.
5. Loosen two front panel captive head screws on pulse generator and pull pulse generator out of control-indicator to expose top deck controls and circuit cards.
6. On top deck of pulse generator, adjust PREC CENTER-HORIZ control to position start of artificial sweep 1/2 inch from left edge of display.
7. Check that sweep is parallel to center grid line. If not, refer to a higher category of maintenance.

4-28. CIRCUIT ALINEMENT. (CONT)

PRECISION DISPLAY ADJUSTMENTS (CONT)

8. On pulse generator, rotate ART ANGLE V control fully counterclockwise.
9. On top deck of pulse generator, adjust PREC CENTER-VERT A2 control to position artificial sweep directly under bottom grid line of navigational grid.
10. On pulse generator, adjust ART ANGLE V control to indicate 300.
11. On top deck of pulse generator, adjust EXP-AZ 300 control to position artificial sweep 118 inch below center grid line of navigational grid.
12. On pulse generator, place ANGLE VOLTS switch to EL position.
13. On top deck of pulse generator, adjust PREC CENTER-VERT EL control to position artificial sweep 1/8 inch above center grid line of navigational grid.
14. On pulse generator, adjust ART ANGLE V control to Indicate 220.
15. On top deck of pulse generator, adjust EXP-EL 100 control to position artificial sweep directly under top grid line of navigational grid.
16. On both pulse generators, place SCAN MODE switch to 350EL position.
17. On pulse generator, adjust ART ANGLE V control to indicate 720.
18. On top deck of pulse generator, adjust EXP-EL 350 control to position artificial sweep directly under top grid line of navigational grid.
19. On both pulse generators, place SCAN MODE switch to 600 AZ position.
20. On pulse generator, place ANGLE VOLTS switch to AZ position and adjust ART ANGLE V control to indicate 300.
21. On top deck of pulse generator, adjust EXP-AZ 600 control to position artificial sweep 118 inch below center grid line of navigational grid.
22. On pulse generator, place RANGE MILES switch to position 10. Adjust applicable PREC DELAY control so that td range mark is just visible at start of sweep.
23. On sweep generator card in pulse generator, adjust R4503 SWEEP GATE LENGTH control for
24. On sweep generator card in pulse generator, adjust R21 5,10 PREC EXP control to position 10- mile range mark 112 inch from right edge of display.
25. On pulse generator, place RANGE MILES switch to position 20.
26. On sweep generator card in pulse generator, adjust R4503 SWEEP GATE LENGTH control for
27. On sweep generator card in pulse generator, adjust R20 20, 40 PREC EXP control to position 20-mile range mark 1/2 inch from right edge of display.
28. On pulse generator, place ANGLE VOLTS switch to OPERATE position.
29. On pulse generator, place RANGE MILES switch alternately to 5, 10, 20, and 40 positions and ensure sweep length is adequate to display corresponding range marks. If sweep length is short in any range, adjust R3 SWEEP GATE LENGTH control on sweep generator card in pulse generator to obtain proper sweep length in that range.
30. On both pulse generators, place RANGE MILES switch to 10 position.
31. On range mark generator card in pulse generator, adjust R4 1 MILE AMPL control for optimum 1- mile range mark intensity.
32. On range mark generator card in pulse generator, adjust R23 5 MILE AMPL control for optimum 5-mile range mark intensity.
33. Push pulse generator into control-indicator and secure with two captive head screws on front panel of pulse generator.

4-28. CIRCUIT ALINEMENT. (CONT)

LOCATION OF TARGET SIMULATORS ON RADAR DISPLAYS

This procedure requires two persons: one should be positioned at radar site, the other at control- indicator site.

Locate, and note for future reference, positions of target simulators on radar displays as described in steps 1 through 17.

NOTE

See paragraphs 2-1 and 4-34 for location and description of operator and organizational controls, indicators, and switches.

1. Perform Preliminary Operating Procedure (para 2-5).
2. On both pulse generators, place the following controls to positions indicated.

| CONTROL | POSITION |
|-------------|----------|
| SCAN MODE | NORM |
| SCAN | OFF |
| RANGE MILES | 5 |

3. On master control-indicator, place TRANSMITTER switch to OFF position.
4. At radar site, attach siting scope to azimuth antenna siting scope mount (para 4-20).

NOTE

Target simulators must be located on radar displays of both master and slave control-indicators. Perform steps 5 through 17 to locate target simulators on radar display of master control-indicator and then repeat these steps for slave control-indicator.

5. Site through siting scope and manually rotate azimuth antenna until vertical crosshair of siting scope is alined with target simulator being located on azimuth display.

CAUTION

Ensure pulse generator does not fall when being pulled out of control-indicator. Do not pull pulse generator completely out of control-indicator unless adequate support is provided.

NOTE

Because radar set allows for alinement of two sets of cursors, there are two sets of cursor alinement controls located on top deck of pulse generator. When CURSOR SELECT switch is placed in position 1, cursor alinement controls to left are used. When switch is placed in position 2, cursor alinement controls to right are used.

6. Loosen two knurled screws on front panel of pulse generator and pull out of control-indicator to expose top deck controls.

4-28. CIRCUIT ALINEMENT. (CONT)

LOCATION OF TARGET SIMULATORS ON RADAR DISPLAYS (CONT)

7. Place CURSOR SELECT switch to position 1 or 2.
8. Place corresponding RUNWAY switch to position L or R, determined by whether radar set is located left or right of runway, as viewed by pilot of approaching aircraft.
9. On master control-indicator, place ANT POL switch to LIN position.

WARNING

To prevent exposure to hazardous rf radiation, ensure no personnel are within an 80- foot (24.5 m) radius of azimuth antenna before performing step 10.

10. On master pulse generator, place TRANSMITTER switch to WIDE PLS position and press HV ON switch.

NOTE

There is a 3-minute time delay after ac power is applied before transmitter will operate.

11. On control-indicator, rotate INTENSITY control clockwise until operate sweep trace is visible on azimuth display. Operate sweep trace represents direction of azimuth antenna in azimuth.
12. If necessary, using ANTENNA switch on master control-indicator, tilt azimuth antenna to obtain better resolution of target simulators on radar display.
13. On pulse generator, alternately place ANGLE VOLTS switch in AZ and OPERATE positions.

NOTE

When ANGLE VOLTS switch is placed to AZ position, an artificial sweep trace will appear on azimuth display. In OPERATE position, operate sweep trace will appear on azimuth display. By switching back and forth, both sweep traces can be seen at the same time.

14. On pulse generator, adjust ART ANGLE V control until artificial sweep trace coincides with operate sweep trace. Record ART ANGLE V control dial indication.
15. On pulse generator, return ANGLE VOLTS switch to OPERATE position and place SCAN switch
16. On pulse generator, momentarily place ANGLE VOLTS switch to AZ position and then back to OPERATE. Target simulator will be found along persisting artificial sweep trace.

NOTE

If target simulator cannot be located as indicated in step 15, place ANGLE VOLTS switch to AZ position and direct second person to alternately remove and replace target simulator. The return that appears and disappears is the target reflector.

17. Repeat steps 1 through 16 to locate all target simulators on the radar display.

4-28. CIRCUIT ALINEMENT. (CONT)

DETERMINING ELEVATION CURSOR ALINEMENT ANGLE

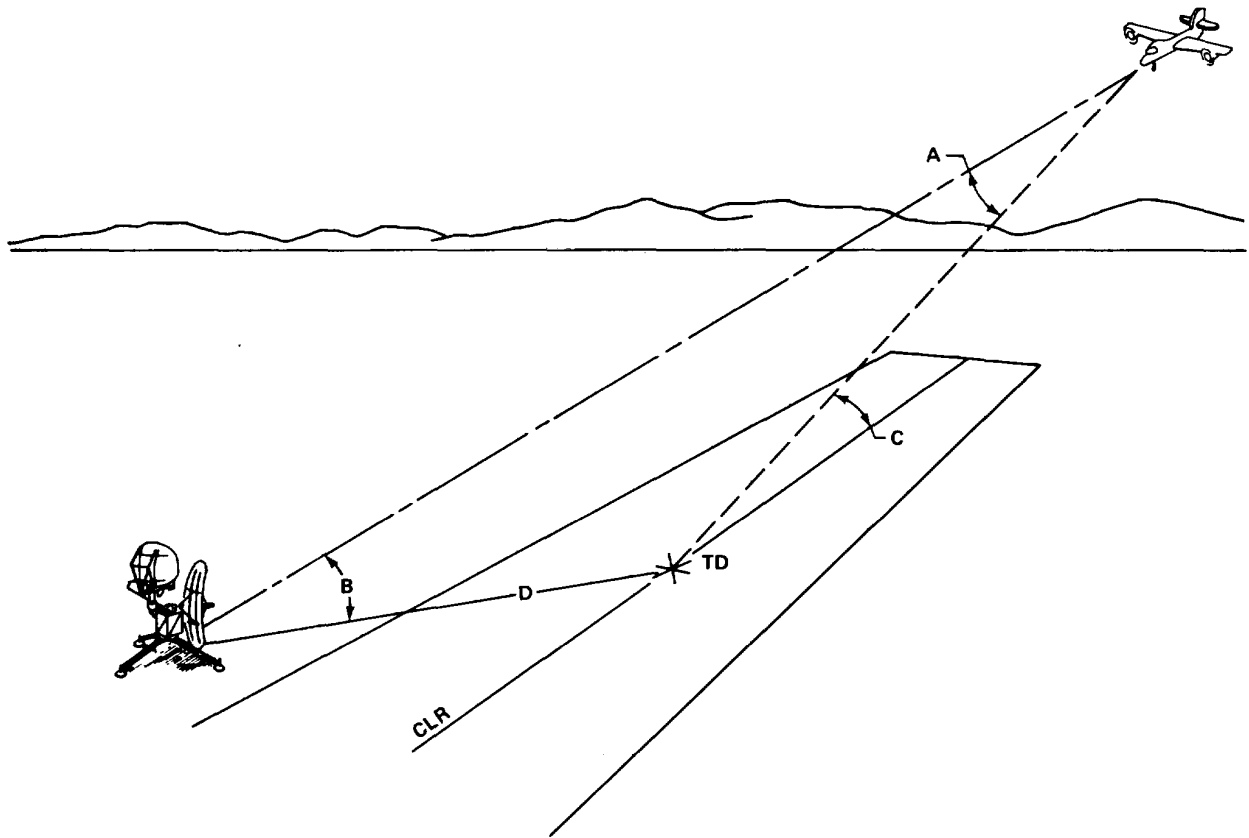

305NE151

Elevation cursor alignment angle (B) is an angle from radar set group to aircraft when aircraft is 5 miles plus distance D (distance from radar set group to td point) from td point. Because radar set group is located 400 feet (122 m) or more down runway from td point, elevation cursor alignment angle will always be less than glidepath angle (C). To calculate elevation cursor alignment angle, the elevation 5mile intercept angle (A) must first be determined. Find elevation cursor alignment angle for each runway approach as follows.

4-28. CIRCUIT ALINEMENT. (CONT)

DETERMINING ELEVATION CURSOR ALINEMENT ANGLE (CONT)

1. Determine sine elevation 5-mile intercept angle (A) using following equation:

$$\text{Sine of angle A} = \frac{D \times \text{sine (Angle GP} \pm \text{Angle GA)}}{D + 30,400}$$

where

- D = distance from radar set group to td (para 4-26)
- Angle GP = glidepath angle in degrees
- Angle GA = elevation ground angle in degrees (para 4-25).

When elevation ground angle is negative, add it to glidepath angle. When elevation ground angle is positive, subtract it from glidepath angle.

2. After sine of elevation 5-mile Intercept angle (A) has been determined, convert it to the nearest tenth of a degree using following table.

| ANGLE | SINE | ANGLE | SINE |
|-------|---------|-------|---------|
| 0.0 | 0.00000 | 3.0 | 0.05234 |
| 0.1 | 0.00175 | 3.1 | 0.05408 |
| 0.2 | 0.00349 | 3.2 | 0.05582 |
| 0.3 | 0.00524 | 3.3 | 0.05756 |
| 0.4 | 0.00698 | 3.4 | 0.05931 |
| 0.5 | 0.00873 | 3.5 | 0.06105 |
| 0.6 | 0.01047 | 3.6 | 0.06279 |
| 0.7 | 0.01222 | 3.7 | 0.06453 |
| 0.8 | 0.01396 | 3.8 | 0.06627 |
| 0.9 | 0.01571 | 3.9 | 0.06802 |
| 1.0 | 0.01745 | 4.0 | 0.06976 |
| 1.1 | 0.01920 | 4.1 | 0.07150 |
| 1.2 | 0.02094 | 4.2 | 0.07324 |
| 1.3 | 0.02269 | 4.3 | 0.07498 |
| 1.4 | 0.02443 | 4.4 | 0.07672 |
| 1.5 | 0.02618 | 4.5 | 0.07846 |
| 1.6 | 0.02792 | 4.6 | 0.08020 |
| 1.7 | 0.02967 | 4.7 | 0.08194 |
| 1.8 | 0.03141 | 4.8 | 0.08368 |
| 1.9 | 0.03316 | 4.9 | 0.08542 |
| 2.0 | 0.03490 | 5.0 | 0.08716 |
| 2.1 | 0.03664 | 5.1 | 0.08889 |
| 2.2 | 0.03839 | 5.2 | 0.09063 |
| 2.3 | 0.04013 | 5.3 | 0.09237 |
| 2.4 | 0.04188 | 5.4 | 0.09411 |
| 2.5 | 0.04362 | 5.5 | 0.09585 |
| 2.6 | 0.04536 | 5.6 | 0.09758 |
| 2.7 | 0.04711 | 5.7 | 0.09932 |
| 2.8 | 0.04885 | 5.8 | 0.10106 |
| 2.9 | 0.05059 | 5.9 | 0.10279 |

4-28. CIRCUIT ALINEMENT. (CONT)

| ANGLE | SINE | ANGLE | SINE |
|-------|---------|-------|---------|
| 6.0 | 0.10453 | 8.1 | 0.14090 |
| 6.1 | 0.10626 | 8.2 | 0.14263 |
| 6.2 | 0.10800 | 8.3 | 0.14436 |
| 6.3 | 0.10973 | 8.4 | 0.14608 |
| 6.4 | 0.11147 | 8.5 | 0.14781 |
| 6.5 | 0.11320 | 8.6 | 0.14954 |
| 6.6 | 0.11494 | 8.7 | 0.15126 |
| 6.7 | 0.11667 | 8.8 | 0.15299 |
| 6.8 | 0.11840 | 8.9 | 0.15471 |
| 6.9 | 0.12014 | 9.0 | 0.15643 |
| 7.0 | 0.12187 | 9.1 | 0.15816 |
| 7.1 | 0.12360 | 9.2 | 0.15988 |
| 7.2 | 0.12533 | 9.3 | 0.16160 |
| 7.3 | 0.12706 | 9.4 | 0.16333 |
| 7.4 | 0.12880 | 9.5 | 0.16505 |
| 7.5 | 0.13053 | 9.6 | 0.16677 |
| 7.6 | 0.13226 | 9.7 | 0.16849 |
| 7.7 | 0.13399 | 9.8 | 0.17021 |
| 7.8 | 0.13572 | 9.9 | 0.17198 |
| 7.9 | 0.13744 | 10.0 | 0.17360 |
| 8.0 | 0.13917 | | |

3. Subtract elevation 5-mile intercept angle (A) from glidepath angle (C) to find elevation alinement angle (B). Record this angle for future use.

DETERMINING ANGLE VOLTS SETTING FOR AZIMUTH OFFSET ANGLE

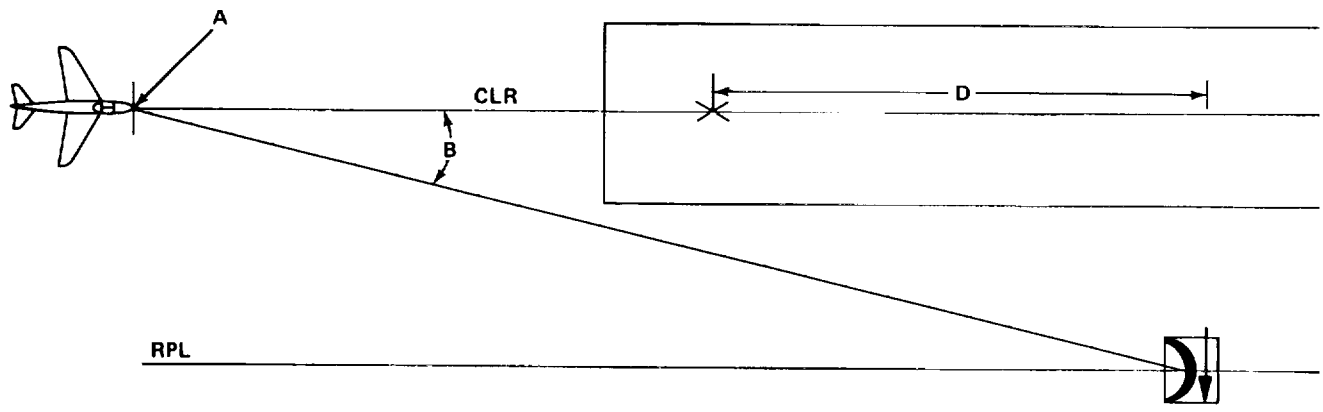

305NE152

Because radar set is offset from center of runway, an angle exists between radar set group and a point (A) 5 miles from aircraft on CLR (aircraft course line). This is azimuth offset angle (B). This angle is used during azimuth cursor alinement and is represented by a specific setting of ANGLE VOLTS control on pulse generator. Determine pulse generator ANGLE VOLTS control setting for each runway approach by performing the following steps.

4-28. CIRCUIT ALINEMENT. (CONT)

DETERMINING ANGLE VOLTS SETTING FOR AZIMUTH OFFSET ANGLE (CONT)

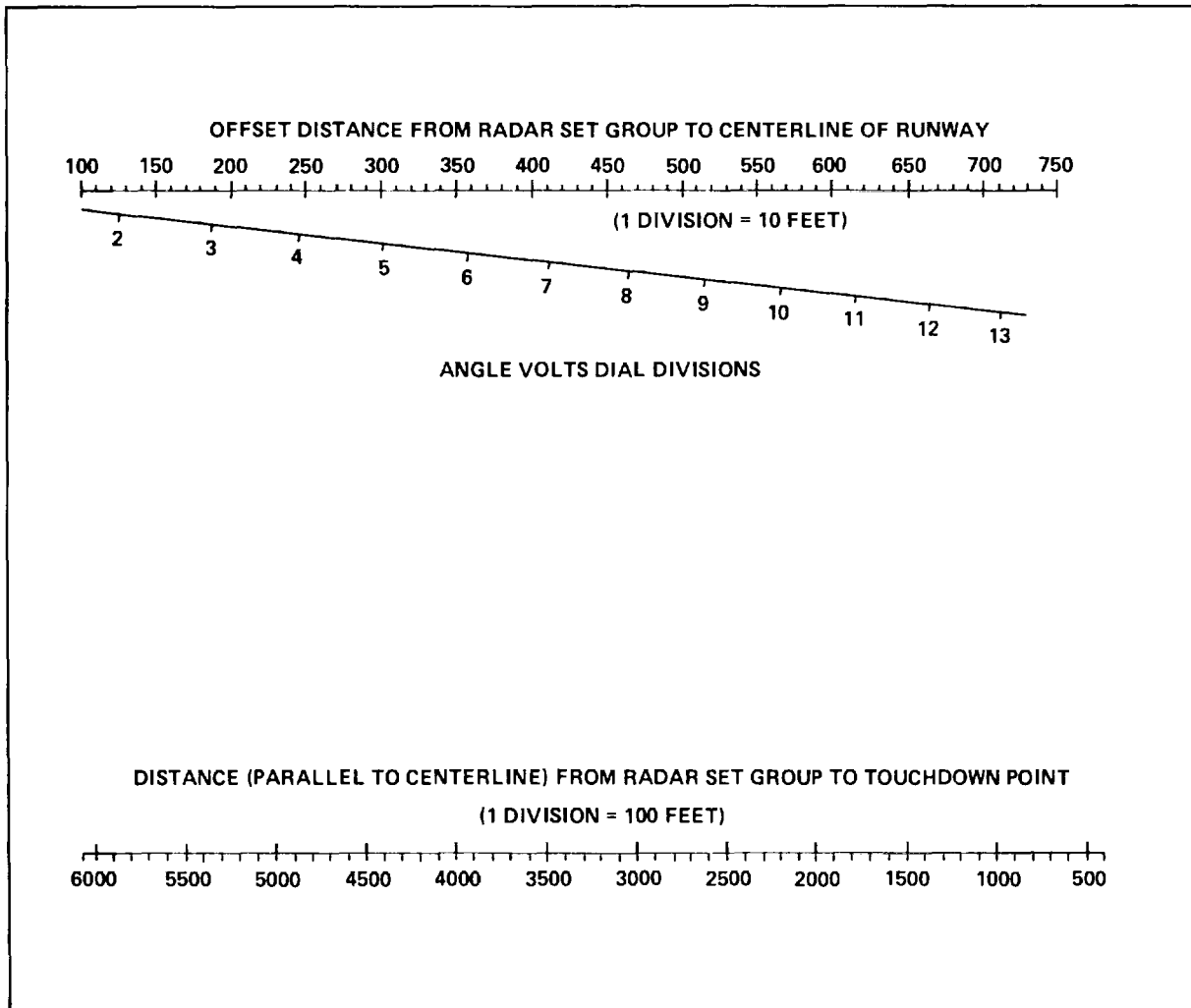

305NE169

1. On top scale of azimuth nomograph above, locate and mark the point that represents radar offset from centerline distance determined in Siting of Target Simulators (para 4-26).
2. On bottom scale of azimuth nomograph, locate and mark the point that represents distance from radar set group to touchdown point determined in Siting of Target Simulators (para 4-26).
3. Using straightedge, connect points marked in steps 1 and 2. Record the value at point of intercept on ANGLE VOLTS DIAL DIVISIONS line. This is the setting representing azimuth offset angle.

CURSOR ALINEMENT

Up to two sets of cursors can be aligned for each control-indicator, depending on the number of runways being given gca service. If only one runway is receiving gca service, align one set of cursors on both master and slave control-indicators. If two runways are being given gca service, align two sets of cursors to their respective runways on both master and slave control-indicators. Use the following cursor alignment procedures for each set of cursors to be aligned.

4-28. CIRCUIT ALINEMENT. (CONT)**NOTE**

Unless otherwise indicated, perform procedures below only on control-indicator or pulse generator whose cursors are being alined.

Azimuth Cursor

1. Ensure all controls and switches are in positions indicated in Preliminary Operating Procedure
2. On master and slave pulse generators, place SCAN MODE switch to NORM and RANGE MILES switch to 10 position.
3. On pulse generator, place ANGLE VOLTS switch to OPERATE position.
4. On master pulse generator, place TRANSMITTER switch to WIDE PLS position and press HV ON Indicator switch.

CAUTION

Ensure pulse generator does not fall when being pulled out of control-indicator. Do not pull pulse generator completely out of control-indicator unless adequate support is provided.

5. Loosen two knurled screws on front of pulse generator and pull out of control-indicator to expose top deck controls
6. On top deck of pulse generator, place CURSOR SELECT switch to position 1 or 2 as applicable.
7. Place corresponding RUNWAY switch to position L or R, depending on whether radar set is located left or right of runway, as viewed by pilot of approaching aircraft.

NOTE

Perform steps 8 through 13 if td bracketing target simulators are used. If clr target simulator is used, perform steps 14 through 19.

4-28. CIRCUIT ALINEMENT. (CONT)

CURSOR ALINEMENT (CONT)

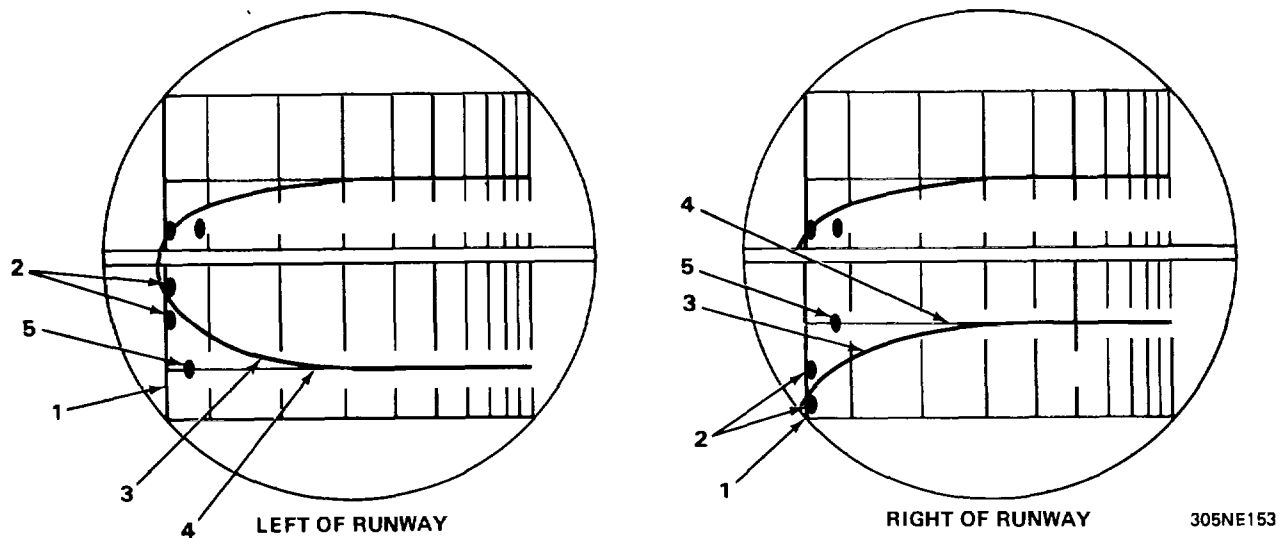

NOTE

For left-of-runway coverage, azimuth cursor will curve up. For right-of-runway coverage, azimuth cursor will curve down.

8. On pulse generator, identify td range mark (1) and adjust applicable PREC DELAY control so that td range mark (1) passes through leading edge of td bracketing target simulator return (2) on azimuth display.
9. On pulse generator, adjust applicable OFF SET control so that azimuth cursor (3) bisects distance between td bracketing target simulator return (2).

NOTE

By placing ANGLE VOLTS switch back and forth in OPERATE and AZ positions, artificial sweep trace and rpl target simulator return can be viewed at the same time.

10. Alternately change ANGLE VOLTS switch on pulse generator between OPERATE and AZ positions.
11. On pulse generator, adjust ART ANGLE V control until artificial sweep trace (4) bisects rpl target simulator return (5). Record ART ANGLE V control dial indication.
12. For left-of-runway coverage, add ART ANGLE V control dial setting, representing azimuth offset angle previously determined, to dial indication recorded in step 11. For right-of-runway coverage, subtract dial indication representing azimuth offset angle from dial setting recorded in step 11. New dial indication (sum or difference) is 5-mile intercept setting. Record this value for use in subsequent azimuth cursor alinements.
13. Determine 5-mile intercept setting of ART ANGLE V control for each approach by performing steps 8 through 12.

4-28. CIRCUIT ALINEMENT. (CONT)

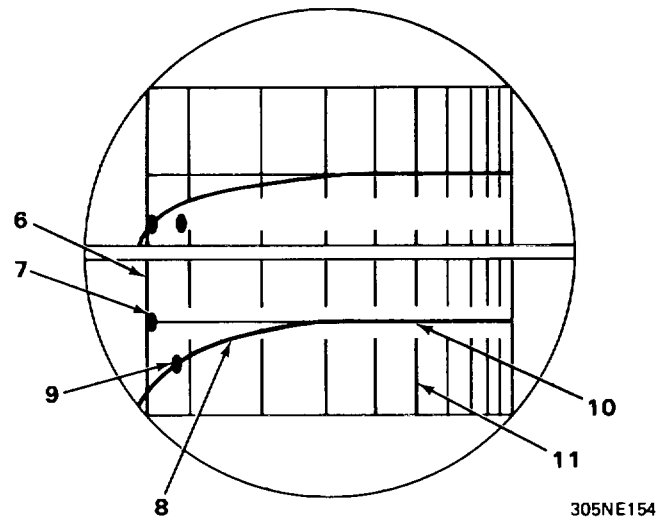
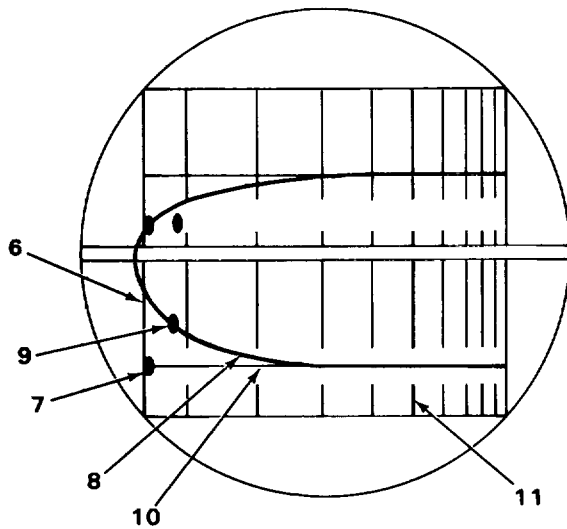

NOTE

For left-of-runway coverage, azimuth cursor will curve up. For right-of-runway coverage, azimuth cursor will curve down.

14. On pulse generator, identify td range mark (6) and adjust applicable PREC DELAY control so td range mark (6) passes through leading edge of td-rpl target simulator return (7).
15. On pulse generator adjust applicable OFF-SET control so azimuth cursor (8) bisects clr target simulator return (9).

NOTE

By switching ANGLE VOLTS switch back and forth in AZ and OPERATE positions, artificial sweep trace and td-rpl target simulator return can be viewed at the same time.

16. Alternately change ANGLE VOLTS switch on pulse generator between OPERATE and AZ positions.
17. Adjust ART ANGLE V control on pulse generator until artificial sweep trace (10) bisects td-rpl target simulator return (7). Record ART ANGLE V control dial indication.
18. For left-of-runway coverage, add ART ANGLE V control dial setting, representing azimuth offset angle determined previously, to dial indication recorded in step 17. For right-of-runway coverage, subtract dial indication representing azimuth offset angle from dial setting recorded in step 17. New dial indication (sum or difference) is 5-mile intercept setting. Record this value for use in subsequent azimuth cursor alinements.
19. Determine 5-mile intercept setting of ART ANGLE V control for each approach by performing steps 14 through 18.
20. If necessary, adjust applicable OFF-SET control on pulse generator so azimuth cursor (3) bisects distance between td bracketing target simulator returns (step 9) or bisects clr target simulator return (5) if clr target simulator is used.

4-28. CIRCUIT ALINEMENT. (CONT)**CURSOR ALINEMENT (CONT)**

21. Accurately set ART ANGLE V control on pulse generator to 5-mile intercept setting recorded in step 12 or 17.
22. Adjust applicable CL VER control on pulse generator to midposition.
23. Alternately place ANGLE VOLTS switch on pulse generator in AZ and OPERATE positions. Adjust applicable COURSELINE and CL VER controls so azimuth cursor (3) intersects 5-mile range mark (11) where artificial sweep trace (10) crosses 5-mile range mark (11).
24. Repeat steps 20 through 25 until azimuth cursor (3) is positioned as indicated in both steps 20 and 23.

Elevation Cursor

This procedure requires two personnel: one at radar site and one at control-indicator site.

1. Ensure all controls and switches are in positions indicated in Preliminary Operating Procedure (para 2-5).
2. On transmitter main power panel, place SCAN and HV switches to OFF position.
3. At radar site, Install clinometer on elevation antenna clinometer mount. See Clinometer Installation (para 4-21).
4. Adjust clinometer to indicated ground angle determined in paragraph 4-9. Manually tilt elevation antenna until clinometer bubble is centered. Maintain antenna in this position.

NOTE

By switching ANGLE VOLTS switch back and forth in EL and OPERATE positions, operate and artificial sweep traces can be viewed at the same time.

5. On pulse generator, alternately place ANGLE VOLTS switch in EL and OPERATE positions. Adjust ART ANGLE V control so artificial sweep trace coincides with operate sweep trace on elevation display. Record ART ANGLE V control dial indication. This is the control setting for elevation cursor alinement at td (td setting).
6. Adjust clinometer to indicate elevation cursor alinement angle determined previously, then manually tilt elevation antenna until clinometer bubble gives level indication.
7. On pulse generator, alternately place ANGLE VOLTS switch in EL and OPERATE positions. Adjust ART ANGLE V control so artificial sweep trace coincides with operate sweep trace on elevation display. Record ART ANGLE V control dial indication. This is the ART ANGLE V control setting for 5-mile intercept (gp setting).

WARNING

To prevent injury to personnel from scanning, radiating antennas, ensure SCAN switch on master pulse generator and TRANSMITTER switch on master control-indicator are in OFF position before performing step 8.

8. Place SCAN switch and HV switch on receiver-transmitter main power panel to ON position.

4-28. CIRCUIT ALINEMENT. (CONT)

- On pulse generator, place following switches to position indicated.

| SWITCH | POSITION |
|-------------|----------|
| EL CURSOR | GP |
| RANGE MILES | 10 |
| SCAN MODE | NORM |
| ANGLE VOLTS | OPERATE |

- Place SCAN switch on master pulse generator to ON position.

WARNING

To prevent exposure to hazardous rf radiation, ensure no personnel are within an 80- foot (24.5 m) radius of radar site before performing step 11.

- On master control-indicator, place TRANSMITTER switch to WIDE PLS position and press HV ON indicator switch.
- Accurately set ART ANGLE V control dial for td setting recorded in step 5.

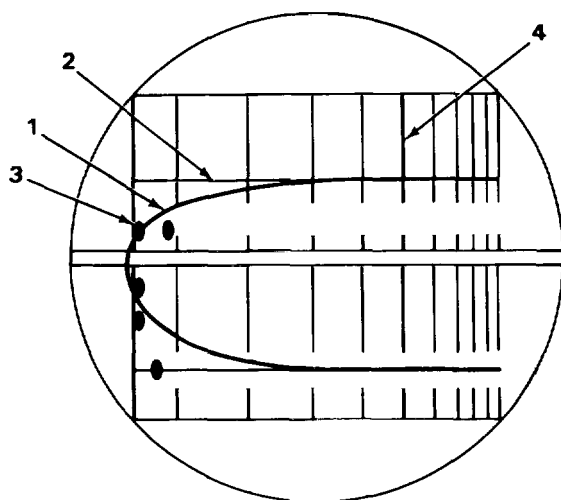

LEFT OF RUNWAY

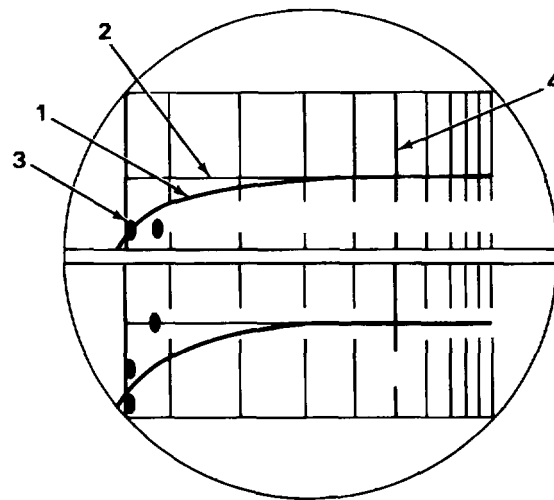

RIGHT OF RUNWAY

305NE155

- Alternately place ANGLE VOLTS switch in EL and OPERATE positions. Adjust applicable TD control to position elevation cursor (1) at intersection of artificial sweep trace (2) and td target simulator return (3).
- Accurately set ART ANGLE V control for gp setting recorded in step 7.
- Place applicable GP VER switch to midposition.
- Alternately place ANGLE VOLTS switch in EL and OPERATE positions. Adjust applicable GP and GP VER control to position elevation cursor (1) at intersection of 5-mile range mark (4) and artificial sweep trace (2).
- Repeat steps 12 through 16 until elevation cursor is positioned as indicated in both steps 13 and 16.

4-28. CIRCUIT ALINEMENT. (CONT)**CURSOR ALINEMENT (CONT)****Height-Finder Cursor**

The height finder cursor, which represents a straight horizontal line in space, is calibrated against two points of intercept using scan angles of elevation antenna. One point of intercept is at 2 miles, where scan angle from horizontal is 1.41 degrees and altitude above horizontal is 300 feet. The second point is at 10 miles, where scan angle from horizontal is 13.8 degrees and altitude above horizontal is 15,000 feet. Two personnel are required to perform this procedure: one at radar site and one at receiver-transmitter site.

1. Ensure all controls and switches are in positions indicated in Preliminary Operating Procedure (para 2-5).
2. On pulse generator, place EL CURSOR switch to HF position and SCAN MODE switch to 350 EL position.
3. Set ALTITUDE control on pulse generator so field elevation is indicated in ALTITUDE indicator window.
4. Disengage ALTITUDE control by pressing and holding drive shaft on right side of indicator window. Rotate ALTITUDE control fully counterclockwise. Release drive shaft to engage altitude indicator.

NOTE

ALTITUDE indicator window now indicates elevation of field when ALTITUDE control is fully counterclockwise.

5. On receiver-transmitter main power panel, place SCAN and HV switches to OFF position.
6. At radar site, install clinometer on elevation antenna clinometer mount, Clinometer Installation (para 4-21).
7. Adjust clinometer to indicate elevation angle of 1.41 degrees, then manually rotate elevation antenna until bubble level gives level indication.
8. On pulse generator, alternately place ANGLE VOLTS switch into EL and OPERATE positions. Adjust ART ANGLE V control until artificial sweep trace coincides with operate sweep trace on elevation display. Record ART ANGLE V dial indication that represents 2-mile intercept setting.
9. Adjust clinometer to indicate 13.8 degrees, then manually rotate elevation antenna until bubble level gives level indication.
10. Alternately place ANGLE VOLTS switch on pulse generator in EL and OPERATE positions. Adjust ART ANGLE V control until artificial sweep trace coincides with operate sweep trace on elevation display. Record ART ANGLE V control dial indication that represents 10-mile intercept setting.
11. On receiver transmitter main power panel, place SCAN on HV switches to ON position.

4-28. CIRCUIT ALINEMENT. (CONT)

WARNING

To prevent exposure to hazardous rf radiation, ensure no personnel are within an 80- foot (24.5 m) radius of radar site before performing step 12.

12. On master control-indicator, place TRANSMITTER switch to WIDE PLS position and press HV ON indicator switch.
13. If necessary, adjust applicable PREC DELAY control on pulse generator so td range mark passes through leading edge of td bracketing simulator returns (or td-rpl target simulator return when used).
14. On master control-indicator, place TRANSMITTER switch to OFF position.
15. On pulse generator, set ART ANGLE V control for 2-mile intercept setting recorded in step 8.
16. Set ALTITUDE control to indicate field elevation plus 300 feet in ALTITUDE indicator window.

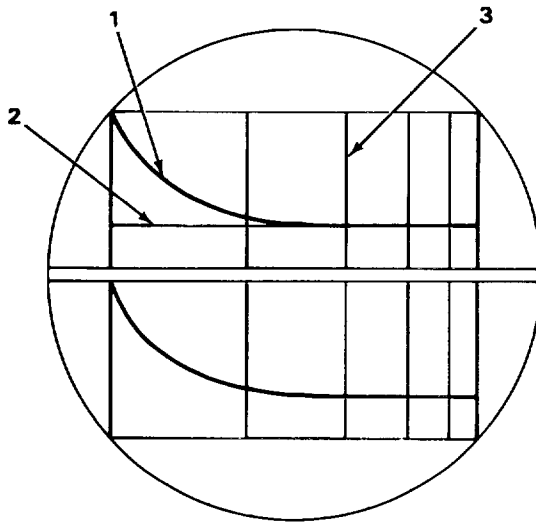

305NE156

17. Alternately place ANGLE VOLTS switch on pulse generator in EL and OPERATE positions. Adjust HF1 control to position height finder cursor (1) at intersection of artificial sweep (2) and 2-mile range mark (3).
18. On pulse generator, place RANGE MILES switch to 20 position.
19. Set ALTITUDE control on pulse generator to indicate field elevation plus 15,000 feet in ALTITUDE indicator window.

4-28. CIRCUIT ALINEMENT. (CONT)

CURSOR ALINEMENT (CONT)

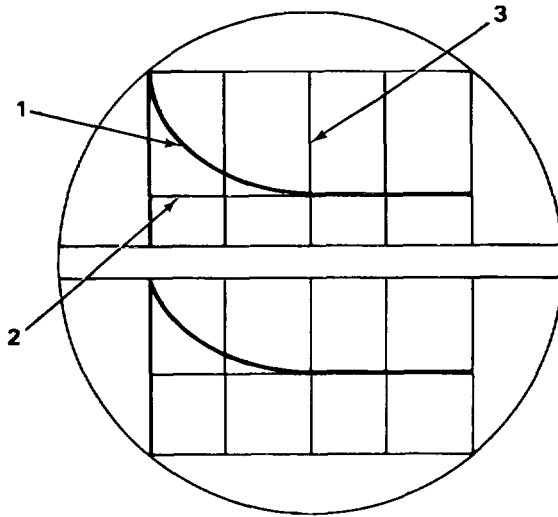

305NE157

20. Alternately place ANGLE VOLTS switch in EL and OPERATE positions. Adjust HF2 control to position height finder cursor (1) at intersection of artificial sweep (2) and 10-mile range mark (3).
21. Repeat steps 16 through 20 until height finder cursor (1) is aligned as indicated in both steps 17 and 20.

PPI DISPLAY ADJUSTMENT

NOTE

Unless otherwise indicated, perform the following steps on control-indicator where ppi display adjustments are being performed.

1. On both pulse generators place the switches below to the positions indicated.

| SWITCH | POSITION |
|--------------------|----------|
| SCAN MODE switch | SEARCH |
| RANGE MILES switch | 5 |
| SCAN switch | ON |

4-28. CIRCUIT ALINEMENT. (CONT)

2. On control-indicator, turn VIDEO GAIN control fully counterclockwise.
3. On control-indicator, adjust VERT and HORIZ PPI CENTERING controls to center start of ppi sweep on display.
4. On range mark generator card, adjust R41 10-MILE AMPL control for optimum 10-mile range mark intensity.
5. Loosen two front panel captive head screws on pulse generator and pull pulse generator out of control-indicator to expose top deck controls and circuit cards.
6. On top deck of pulse generator, adjust PPI DELAY control until initial range mark (touchdown range mark) is just visible at start of sweep.
7. On pulse generator, place RANGE MILES switch to 20 position.
8. On sweep generator card in pulse generator, adjust R22 PPI SWEEP EXP control to position 20-mile range mark 1/8 inch from edge of display.
9. On pulse generator, place RANGE MILES switch to 40 position.
10. On sweep generator card in pulse generator, adjust R4503 SWEEP GATE LENGTH control so sweep length just passes 40-mile range mark.
11. On pulse generator, place RANGE MILES switch alternately to 40, 20, 10, and 5 positions. Verify that sweep length extends across the radius of the crt in all ranges. If sweep length is short in any range, readjust R4503 SWEEP GATE LENGTH to obtain proper sweep length in that range.

NOTE

If associated IFF equipment is being used, perform steps 12 thru 14 below. If not, proceed to step 15.

12. On pulse generator, place RANGE MILES switch to 80 position.
13. On range mark generator card, readjust R41 10 MILE AMPL control for optimum 10-mile range mark intensity.
14. Unlatch four latch locks securing rear cover of control-indicator and remove cover.
15. On mixer amplifier, adjust R41 IFF VIDEO for optimum operating level.
16. On pulse generator, place RANGE MILES switch to 10 position.
17. On range mark generator card in pulse generator, adjust R23 5 MILE AMPL control for optimum 5-mile range mark intensity.
18. On range mark generator card in pulse generator, adjust R41 1 MILE AMPL control for optimum 1-mile range mark intensity.
19. Push pulse generator into control-indicator and secure with two captive head screws on front panel of pulse generator.

4-28. CIRCUIT ALINEMENT. (CONT)**PPI ORIENTATION**

To orient ppi display, three targets of known range and azimuth bearings must be selected. The ppi display is oriented to one target and its accuracy is then checked using the other two targets of known range and azimuth bearings.

WARNING

To prevent exposure to hazardous rf radiation, ensure no personnel are within an 80- foot (24.5 m) radius of radar site before performing step 1.

NOTE

If radar set is operated with IFF equipment, ppi display is oriented when radar set IFF system synchros are alined. Refer to TM 11-5895-468-12 for alinement of radar set IFF system synchros.

The ppi orientation procedure must be performed for both control-indicators. Unless otherwise indicated, perform the following steps only on control-indicator on which ppi orientation procedure is being performed.

1. On master control-indicator, place TRANSMITTER switch to WIDE PLS position and press HV OF indicator switch.
2. On master pulse generator, place SCAN switch to ON position.
3. On pulse generator, place SCAN MODE switch to SEARCH position.
4. Perform Crt Display Adjustments (para 2-5).

NOTE

A grid line overlay, which is located over radar display, is used to center the start of ppi display.

5. Set RANGE MILES switch on pulse generator to a position that will result in one of three targets of known bearing to be located as close to the edge of ppi display as possible.
6. Unlatch five link locks and remove control-indicator rear cover.
7. Adjust PPI ORIENT control on back of control-indicator until target (step 5) is located at proper bearing on compass rose ring.
8. Adjust PPI DELAY control on top deck of pulse generator so target is at proper range on crt.
9. Check that bearings of two remaining targets on compass rose ring are within 2 degrees of their actual bearings and at proper range.
10. Slide pulse generator back in control-indicator and secure with two knurled front panel screws.
11. Place TRANSMITTER switch on master control-indicator to OFF position.
12. On pulse generator, place SCAN switch to OFF position.

PERFORMANCE TESTS

A system performance check should be performed prior to any operational activity. The performance test procedures are the responsibility of organizational personnel. These procedures are located in section V of this chapter.

Section III ORGANIZATIONAL PREVENTIVE MAINTENANCE CHECKS AND SERVICES

| | | |
|---|------|-------|
| Subject | Para | Page |
| General | 4-29 | 4-103 |
| Organizational Preventive Maintenance Checks and Services | 4-30 | 4-103 |

4-29. GENERAL.

Organizational preventive maintenance checks and services are designed to help maintain radar set in serviceable condition, prevent breakdowns, and ensure maximum operational capability. The PMCS procedures listed in this section include (M) monthly and (Q) quarterly equipment checks.

The routine covering of unused receptacles; stowing of unused equipment; procedures such as equipment inventory, cleaning of components, checking for frayed or broken cables; checking for loose hardware, nuts, bolts, and screws; and touchup painting are not listed in the PMCS table. These are things you should do anytime you see they need to be done. If you find a routine check in the PMCS table, it was listed because other technicians reported problems with this item.

If equipment must be kept in continuous operation, check and service only those things that can be checked and serviced without disturbing operation. Make complete checks and services when equipment can be shut down. If equipment fails to operate, see the organizational troubleshooting steps in this manual. Use DA PAM 738-750 as a guide for reporting problems and using forms.

The ITEM NO. column in the PMCS table is to be used as a source of item numbers for the TM number column on DA Form 2404, Equipment Inspection and Maintenance Worksheet, for recording PMCS results.

NOTE

Keep in mind all warnings and cautions while performing PMCS or routine checks.

4-30. ORGANIZATIONAL PREVENTIVE MAINTENANCE CHECKS AND SERVICES.

M - MONTHLY

Q - QUARTERLY

| ITEM NO. | INTERVAL | | ITEM TO BE INSPECTED | PROCEDURE |
|----------|----------|---|--------------------------------|--|
| | M | Q | | |
| 1 | • | | RADAR SET GROUP Lubrication | Perform lubrication procedures (LO 11-5840-281-12-1). |
| 2 | | • | Waveguide Connections | Check that preformed packings in waveguide and waveguide adapter flanges are properly seated, resilient, and intact. |
| 3 | • | | Ground Rod and Cable W3006 | Check ground rod and cable for clean, tight connection. |

4-30. ORGANIZATIONAL PREVENTIVE MAINTENANCE CHECKS AND SERVICES. (CONT)

M - MONTHLY

Q - QUARTERLY

| ITEM NO. | INTERVAL | | ITEM TO BE INSPECTED | PROCEDURE |
|----------|----------|---|---|---|
| | M | Q | | |
| 4 | • | | Receiver- Transmitter Internal Components ¹ | Open receiver and transmitter doors and check electrical components for burning, arcing, or evidence of overheating. Check all interior surfaces and components for moisture or fungus. |
| 5 | | • | CONTROL-INDICATOR GROUPS CRT | Inspect face of crt for burned spots. |
| 6 | • | | Control- Indicator Internal Components ¹ | Remove rear cover of control-indicator and check electrical components for burning, arcing, or evidence of overheating. Check all interior components for moisture or fungus. |
| 7 | | • | RADAR SET Modification Work Orders | Refer to DA PAM 310-1 to determine if new MWO on radar set have been published. All URGENT MWO must be applied immediately. All NORMAL MWO must be scheduled. |
| 8 | | • | Publications | Requisition replacements for any missing operator and organizational maintenance manuals. |
| 9 | | • | Performance Tests | Conduct performance tests (para 4-47). |

¹When operating radar set in area of high relative humidity, check interior components weekly for moisture or fungus buildup.

Section IV. ORGANIZATIONAL TROUBLESHOOTING

| Subject | Para | Page |
|---------------------------------|------|-------|
| General..... | 4-31 | 4-105 |
| Symptom Index..... | 4-31 | 4-105 |
| Troubleshooting Procedures..... | 4-32 | 4-106 |

4-31. GENERAL.

The troubleshooting table lists malfunctions that may be found while performing PMCS or when equipment is being operated. Before performing troubleshooting procedures, check that all controls and switches are in the proper positions for the mode of operation you are in.

The troubleshooting table does not list all problems that may occur. If your problem is not listed, or if the procedures given do not correct the problem, report it to a higher category of maintenance.

When working on any problem, be sure to report your work on the forms shown in DA PAM 738-750.

To use the troubleshooting table, first locate your problem in the symptom index. The index is divided into two parts. Part 1 lists symptoms that may be found when operating radar set with or without associated IFF equipment. Part 2 gives symptoms that may be found that are related specifically to IFF equipment. The index will give you a page number on which you will find your problem and the possible corrective actions. Turn to the page indicated, locate the problem, and follow the corrective actions given. After a troubleshooting procedure has been accomplished, perform the operational checks in paragraph 3-6 to ensure the equipment is functioning properly.

SYMPTOM INDEX

| | Page |
|--|-------|
| PART 1 | |
| Radar set does not operate when MAIN POWER switch on receiver-transmitter main power panel is placed to ON position | 4-106 |
| Blank crt on either control-indicator | 4-107 |
| No radar video or weak radar video, and HV ON indicator switch on either control-indicator is illuminated | 4-108 |
| No radar video and HV ON indicator switch on either control-indicator is not illuminated | 4-109 |
| No radar video and HV ON indicator switch on either control-indicator is not illuminated. Antennas do not scan or scan erratically | 4-109 |
| Operational controls on master control-indicator do not function | * |
| Indicator switches on transmitter control panel do not light when pressed..... | 4-111 |
| Ppi sweep length is short in any range on either control-indicator | 4-111 |
| Timebase sweep is short or does not begin under center gridline of navigational grid in any range on either control-indicator when in NORM, 35°EL, 600AZ, or SIMULT mode | 4-111 |
| PPI DELAY or PREC DELAY controls have no effect on positioning of range- marks on either control-indicator | * |
| Intensified dot but not timebase sweep on crt of either control-indicator in SEARCH mode | * |
| Intensified dot but no timebase sweep on crt of either control-indicator in NORM, 35°EL, or 60°AZ modes | 4-111 |
| Timebase sweep on crt of either control-indicator will not rotate in SEARCH or SIMULT modes | * |

SYMPTOM INDEX (CONT)

No vertical deflection on elevation and azimuth displays of either control-indicator *

No vertical deflection on azimuth display of either control-indicator 4-112

No vertical deflection on elevation display of either control-indicator 4-114

Displaced centering on any or all scan mode displays on either control-indicator *

No azimuth or elevation cursor on crt of either control-indicator in NORM, 35EL, or 60AZ mode *

Azimuth antenna will not scan in any mode 4-115

Azimuth antenna scans erratically 4-115

Azimuth antenna will not scan in all precision modes (NORM, 350EL, and 60°AZ) *

Azimuth antenna scans wrong sector in NORM, 350EL, or 600AZ mode *

Elevation antenna will not scan in any mode *

Elevation antenna will not switch between 10-degree elevation scan and 35-degree elevation scan..... *

Elevation and azimuth antennas will not scan in any mode *

Azimuth antenna will not tilt up or down..... *

Elevation antenna will not servo right or left *

PART 2

Radar and IFF video not synchronized on both control-indicators at any range in SEARCH and SIMULT modes..... 4-115

Intensified dot but not timebase sweep on crt of both control-indicators in Search and SIMULT modes..... 4-116

No timebase sweep on either control-indicator in IFF mode 4-116

Timebase sweep on both control-indicators will not rotate in IFF mode 4-116

*If this symptom is observed, report the problem to a higher category of maintenance.

4-32. TROUBLESHOOTING PROCEDURES.

MALFUNCTION

TEST OR INSPECTION

CORRECTIVE ACTION

1. Radar set does not operate when MAIN POWER switch on receiver-transmitter main power panel is placed to ON position.

Step 1. Check that primary power source is turned on.

Turn on primary power source.

Step 2. Check cables W3007, W3003, and W3004 for defective connections.

Tighten loose connections.

4-32. TROUBLESHOOTING PROCEDURES. (CONT)

MALFUNCTION

TEST OR INSPECTION

CORRECTIVE ACTION

Step 3. Check cables W3007, W3003, and W3004 for continuity.

Replace defective cable. If problem still persists, refer to a higher category of maintenance.

2. Blank crt on either control-indicator.

Step 1. Check fuse F1907 on rear of control-indicator.

If fuse is blown, momentarily turn off power and replace fuse. If new use blows, refer to a higher category of maintenance.

Step 2. Place BITE-AZ TILT meter select switch to BITE position. Place BITE SELECT switch to + 300V position and observe indication on AZ TILT/BITE meter.

- a. If meter indicates in green zone, proceed to step 3.
- b. If no meter indication is obtained, refer to a higher category of maintenance.
- c. If meter indicates other than green zone, adjust rotating coil amplifier by adjusting R1632 + 300V ADJ until meter indicates in green zone. If adjustment above cannot be accomplished, refer to a higher category of maintenance.

Step 3. Place BITE SELECT switch to + 35V position and observe indication on AZ TILT/BITE meter.

- a. If meter indicates in green zone, proceed to step 4.
- b. If no meter indication is obtained, replace + 35V voltage regulator card (para 4-39) and perform control-indicator power supply adjustments (para 4-42).
- c. If meter indicates other than green zone, adjust 35V voltage regulator card as indicated in 1 through 3 below:
 1. Set up multimeter to measure + 40 v.
 2. Connect positive lead of multimeter to J615 BITE MON and connect negative lead to J616 DC RET.
 3. Adjust R3427 + 35V ADJ on 35V voltage regulator card for + 35V indication on multimeter.

4-32. TROUBLESHOOTING PROCEDURES. (CONT)

MALFUNCTION

TEST OR INSPECTION

CORRECTIVE ACTION

Step 2. Blank crt on either control-indicator. (Cont)

If adjustment in 1 through 3 cannot be accomplished, replace 35V voltage regulator card (para 4-39) and perform control-indicator power supply adjustments (para 4-42).

Step 4. Place BITE SELECT switch to - 12V position and observe indication on AZ TILT/BITE meter.

- a. If meter indicates in green zone, proceed to step 5.
- b. If no meter indication is obtained, replace 12V voltage regulator card (para 4-39) and perform control-indicator power supply adjustments (para 4-42).
- c. If meter indicates other than green zone, adjust 12V voltage regulator card as indicated in 1 through 3.
 1. Set up multimeter to measure - 12 v.
 2. Connect positive lead of multimeter to J616 DC RET and connect negative lead to J615 BITE MON.
 3. Adjust R1808 - 12V ADJ on 12V voltage regulator card for - 12V indication on multimeter.

If adjustment in 1 through 3 above cannot be accomplished, replace 12V voltage regulator card (para 4-39) and perform control-indicator power supply adjustments (para 4-42).

Step 5. Check all fuses in indicator power supply.

- a. If any fuse is blown, momentarily turn off power and replace fuse. If new fuse blows, refer to a higher category of maintenance.
- b. If no fuses are blown, replace indicator rectifier card in control-indicator power supply. If problem still persists, refer to a higher category of maintenance.

3. No radar video or weak radar video, and HV ON indicator switch on either control-indicator is illuminated.

Step 1. Check that correct preselector filters are installed in receiver.

Install correct preselector filters (para 4-27).

4-32. TROUBLESHOOTING PROCEDURES. (CONT)

MALFUNCTION

TEST OR INSPECTION

CORRECTIVE ACTION

Step 2. Check MAGNETRON CURRENT meter on transmitter control panel and observe magnetron current is 9.5 ± 1 ma in narrow pulse operation and 27.5 ± 5.5 ma in wide pulse operation.

If magnetron current is not within above tolerances, refer to a higher category of maintenance.

4. No radar video and HV ON indicator switch on either control-indicator is not illuminated.

On transmitter control panel, press OVLD RESET switch. On master control-indicator, place TRANSMITTER switch to NAR or WIDE position and press HV ON indicators switch.

If HV ON indicator switch does not light, refer to a higher category of maintenance.

5. No radar video and HV ON indicator switch on either control-indicator is not illuminated. Antennas do not scan or scan erratically.

Step 1. On local control monitor, place LOCAL/REMOTE switch to RT position and place MONITOR switch to + 35V position. Observe MONITOR meter indication.

- a. If meter indicates + 35 v, proceed to step 2.
- b. If meter indicates 0 v, replace 35V voltage regulator card (para 4-39) and perform receiver-transmitter power supply adjustments (para 4-41).
- c. If meter indicates other than + 35 v, adjust 35V voltage regulator card as Indicated in 1 through 3.
 1. Set up multimeter to measure + 35 v.
 2. Connect positive lead of multimeter to J5303 VOLTAGE MON and connect negative lead to J5304 GND on local control monitor.
 3. Adjust R3414 + 35V ADJ on 35V voltage regulator card for multimeter indication of + 35 v.

If adjustment in 1 through 3 cannot be accomplished, replace 35V voltage regulator card (para 4-39) and perform receiver-transmitter power supply adjustments (para 4-41).

4-32. ORGANIZATIONAL TROUBLESHOOTING. (CONT)

| |
|--------------------|
| MALFUNCTION |
| TEST OR INSPECTION |
| CORRECTIVE ACTION |

5. No radar video and HV ON indicator switch on either control-indicator is not illuminated. Antennas do not scan or scan erratically. (CONT)

Step 2. Place MONITOR switch to - 35V position and observe MONITOR meter Indication.

- a. If meter indicates - 35 v, proceed to step 3.
- b. If meter indicates 0 v, replace 35V voltage regulator card (para 4-39) and perform receiver-transmitter power supply adjustments (para 4-41).
- c. If meter indicates other than - 35 v, adjust 35V voltage regulator card as indicated in 1 through 3.
 - 1. Set up multimeter to measure 35 v.
 - 2. Connect negative lead of multimeter to J5303 VOLTAGE MON and connect positive lead to J5304 GND on local control monitor.
 - 3. Adjust R3427 - 35 ADJ on 35V voltage regulator card for multimeter indication of - 35 v.

If adjustment in 1 through 3 cannot be accomplished, replace 35V low voltage regulator card (para 4-39) and perform receiver-transmitter power supply adjustments (para 4-41).

Step 3. On local control monitor, place MONITOR switch to + 28V position and observe MONITOR meter Indication.

If MONITOR meter does not indicate + 28 + 4 v, replace rectifier card (para 4-39) and perform receiver-transmitter power supply adjustments (para 4-41).

Step 4. Perform the voltage checks in the table below at the transmitter control unit. MULTIMETER TESTPOINT CONNECTION

| POSITIVE LEAD | NEGATIVE LEAD | INDICATION |
|---------------|---------------|--------------|
| J141 + 28 V | J139 LVPS COM | +28 ± 4.0 V |
| J140 + 12 V | J139 LVPS COM | + 12 ± 0.6 V |
| J139 LVPS COM | J137 - 19 V | - 19 ± 1.5 V |
| J139 LVPS COM | J138 -6V | |

4-32. ORGANIZATIONAL TROUBLESHOOTING. (CONT)

MALFUNCTION

TEST OR INSPECTION

CORRECTIVE ACTION

If any voltages above are not within tolerances indicated, replace receiver-transmitter low-voltage power supply (para 4-40) and perform receiver-transmitter power supply adjustment (para 4-41).

6. Indicator switches on transmitter control panel do not light when pressed.

Remove lamp from switch (para 4-38) and test for continuity.

Replace defective lamp. If problem persists, refer to a higher category of maintenance.

7. Ppi sweep length is short in any range on either control-indicator.

Perform ppi display adjustments (para 4-28).

If ppi display adjustments do not correct problem, refer to a higher category of maintenance.

8. Timebase sweep is short or does not begin under center grid line of navigational grid in any range on either control-indicator, when in NORM, 350 EL, 600 AZ, or SIMULT mode.

Perform precision display adjustments (para 4-28).

If precision display adjustments do not correct problem, refer to a higher category of maintenance.

9. Intensified dot but no timebase sweep on crt of either control-indicator when NORM, 350° EL, 600 AZ, or SIMULT mode.

Step 1. Place BITE-AZ TILT switch to BITE position and place BITE SELECT switch to - 18V VERT position. Observe AZ TILT/BITE meter indication.

- a. If meter indicates in green zone, proceed to step 2.
- b. If no meter indication is obtained, replace 18V voltage regulator card (para 4-39) and perform control-indicator power supply adjustments (para 4-42).
- c. If meter indicates other than green zone, adjust 18V voltage regulator card as indicated in 1 through 3.
 1. Set up multimeter to measure - 20 v.
 2. Connect positive lead of multimeter to J616 DC RET and connect negative lead to J615 BITE MON.

4-32. ORGANIZATIONAL TROUBLESHOOTING. (CONT)

MALFUNCTION

TEST OR INSPECTION

CORRECTIVE ACTION

9. Intensified dot but no timebase sweep on crt of either control-indicator when NORM, 350° EL, 600 AZ, or SIMULT mode. (Cont)

3. Adjust R8702 - 18V VERT ADJ for multimeter indication of - 18 v.

If adjustment in 1 through 3 cannot be accomplished, replace 18V voltage regulator card (para 4-39) and perform control-indicator power supply adjustments (para 4-42).

Step 2. Place BITE SELECT switch to - 18V HORIZ position and observe AZ TILT/BITE meter indication.

- a. If meter indicates in green zone, proceed to step 3.
- b. If no meter indication is obtained, replace 18V voltage regulator card (para 4-39) and perform control-indicator power supply adjustments (para 4-42).
- c. If meter indicates other than green zone, adjust 18V voltage regulator card as indicated in 1 through 3.

1. Set up multimeter to measure - 20 v.
2. Connect positive lead of multimeter to J616 DC RET and connect negative lead to J615 BITE MON.
3. Adjust R8709 - 18V HORIZ ADJ for multimeter indication of - 18 v.

If adjustment in 1 through 3 cannot be accomplished, replace 18V voltage regulator card (para 4-39) and perform control-indicator power supply adjustments (para 4-42).

Step 3. Perform fixed coil amplifier adjustments (para 4-45).

If fixed coil amplifier adjustments cannot be accomplished, replace fixed coil amplifier card (para 4-39) and perform ppi display adjustments and precision display adjustments (para 4-28).

10. No vertical deflection on azimuth display of either control-indicator.

Step 1. Place ANGLE VOLTS switch on pulse generator to AZ position and rotate ART ANGLE V control clockwise and counterclockwise.

If artificial sweep on azimuth display does not move up and down, refer to a higher category of maintenance.

4-32. ORGANIZATIONAL TROUBLESHOOTING. (CONT)

MALFUNCTION

TEST OR INSPECTION

CORRECTIVE ACTION

Step 2. Perform azimuth electronic filter angle volts test indicated in steps a through e.

- a. On receiver-transmitter main power panel, place SCAN switch to OFF position.
- b. On local control monitor, place LOCAUREMOTE switch to RT position and SCAN MODE switch to NORM position.
- c. Set up multimeter to measure + 50 v.
- d. On azimuth electronic filter, connect negative lead of multimeter to TP701 GRD and connect positive lead to TP703 ANGLE VOLTS.

WARNING

Be extremely careful when performing step e to avoid being struck by scanning elevation antenna.

- e. On receiver-transmitter main power panel, place SCAN switch to ON position.

If multimeter indication varies as azimuth antenna scans, refer to a higher category of maintenance.

Step 3. Perform the azimuth electronic filter angle data test indicated in steps a through d.

- a. On receiver-transmitter main power panel, place SCAN switch to OFF position.
- b. Set up multimeter to measure - 30 v.
- c. On azimuth electronic filter, connect negative lead of multimeter to TP702 ANGLE DATA and connect negative lead to TP701 GRD.

WARNING

Be extremely careful when performing step d to avoid being struck by scanning elevation antenna.

- d. On receiver-transmitter main power panel, place SCAN switch to ON position.

If multimeter indication does not vary as azimuth antenna scans, refer to a higher category of maintenance. If multimeter indication varies between - 9 and - 18 v, replace azimuth electronic filter (para 4-40) and perform azimuth electronic filter alinement (para 4-45).

4-32. ORGANIZATIONAL TROUBLESHOOTING. (CONT)

MALFUNCTION

TEST OR INSPECTION

CORRECTIVE ACTION

11. No vertical deflection on elevation display of either control-indicator.
- Step 1. Place ANGLE VOLTS switch on pulse generator to EL position and rotate ART ANGLE V control clockwise and counterclockwise.
- If artificial sweep on elevation display does not move up and down, refer to a higher category of maintenance.
- Step 2. Perform elevation electronic filter angle volts test indicated in steps a through e.
- a. On receiver-transmitter main power panel, place SCAN switch to OFF position.
 - b. On local control monitor, place LOCAUREMOTE switch to RT position and SCAN MODE switch to NORM position.
 - c. Set up multimeter to measure + 50 v.
 - d. On elevation electronic filter, connect negative lead of multimeter to TP701 GRD and connect positive lead to TP703 ANGLE VOLTS.

WARNING

Be extremely careful when performing step e to avoid being struck by scanning elevation antenna.

- e. On receiver-transmitter main power panel, place SCAN switch to ON position.
- If multimeter indication varies as elevation antenna scans, refer to a higher category of maintenance.
- Step 3. Perform elevation electronic filter angle data test indicated in steps a through d.
- a. On receiver-transmitter main power panel, place SCAN switch to OFF position.
 - b. Set up multimeter to measure - 30 v.
 - c. On electronic filter connect negative lead of multimeter to TP702 ANGLE DATA and connect negative lead to TP701 GRD.

4-32. ORGANIZATIONAL TROUBLESHOOTING. (CONT)

MALFUNCTION

TEST OR INSPECTION

CORRECTIVE ACTION

WARNING

Be extremely careful when performing step d to avoid being struck by scanning elevation antenna.

- d. On receiver-transmitter main power panel, place SCAN switch to ON position.

If multimeter indication does not vary as elevation antenna scans, refer to a higher category of maintenance. If multimeter indication varies between - 9 and - 18 v, replace elevation electronic filter (para 4-39) and perform elevation electronic filter alinement (para 4-43).

12. Azimuth antenna will not scan in any mode.

Check fuse F105 on receiver side of receiver-transmitter.

If fuse is blown, momentarily turn off power and replace fuse (para 3-8). If fuse is not blown, or if new fuse blows after replacement, refer to a higher category of maintenance.

13. Azimuth antenna scans erratically in any mode.

Perform azimuth antenna scan adjustment (para 4-46).

If azimuth antenna scan adjustment does not correct problem, refer to a higher category of maintenance.

14. Radar and IFF video not synchronized on both control-indicators at any range in SEARCH and SIMULT modes.

Perform IFF antenna orientation alinement. Refer to TM 11-5895-468-12.

If IFF antenna orientation alinement does not correct problem, IFF synchro data is missing or incomplete. Refer to higher category of maintenance.

4-32. ORGANIZATIONAL TROUBLESHOOTING. (CONT)

MALFUNCTION**TEST OR INSPECTION****CORRECTIVE ACTION**

15. Intensified dot but no timebase sweep on crt of both control-indicators in SEARCH and SIMULT modes.
IFF trigger (1200 pps) missing. Refer to TM 11-5895-468-12 and check associated IFF equipment.
Repair IFF equipment.
16. No timebase sweep on either control-indicator in IFF mode.
IFF trigger (400 pps) missing. Refer to TM 11-5895-468-12 and check associated IFF equipment.
Repair IFF equipment.
17. Timebase sweep on both control-indicators will not rotate in IFF mode.
IFF synchro data missing or incomplete. Refer to TM 11-5895-468-12 and check associated IFF equipment.
Repair IFF equipment.
-

Section V. ORGANIZATIONAL MAINTENANCE PROCEDURES

| Subject | Para | Page |
|---|------|-------|
| General..... | 4-33 | 4-117 |
| Description of Maintenance Controls, Indicators, and Switches | 4-34 | 4-117 |
| Dehydrator Cartridge Replacement | 4-35 | 4-133 |
| Air Filter Cleaning and Servicing | 4-36 | 4-133 |
| Control Knob Replacement | 4-37 | 4-135 |
| Transmitter Control Panel Lamp Replacement | 4-38 | 4-136 |
| Plug-in Circuit Card Replacement | 4-39 | 4-137 |
| Receiver-Transmitter Low Voltage Power Supply Replacement | 4-40 | 4-138 |
| Receiver-Transmitter Power Supply Adjustment..... | 4-41 | 4-139 |
| Control-Indicator Power Supply Adjustment | 4-42 | 4-140 |
| Elevation Electronic Filter Alinement..... | 4-43 | 4-141 |
| Azimuth Electronic Filter Alinement..... | 4-44 | 4-142 |
| Fixed Coil Amplifier Adjustment | 4-45 | 4-142 |
| Azimuth Antenna Scan Adjustment | 4-46 | 4-143 |
| Performance Checks | 4-47 | 4-143 |
| Lubrication | 4-48 | 4-154 |
| Touchup Painting | 4-49 | 4-154 |

4-33. GENERAL.

This section contains organizational maintenance procedures for replacing and adjusting components of radar set using authorized tools and replacement parts. Refer to appendix B, Maintenance Allocation Chart.

The operational check is performed to determine if equipment is functioning properly. If a fault or malfunction is found during the operational check, an appropriate troubleshooting procedure that can be used to locate the faulty item is referenced.

Performance tests are used to detect possible degradation of equipment. If an Incorrect indication is obtained during the performance tests, an appropriate troubleshooting procedure that can be used to locate the faulty item is referenced.

Personnel are not listed unless the task requires more than one technician.

Resources or test equipment required are not listed unless they apply to a particular procedure.

4.34. DESCRIPTION OF MAINTENANCE CONTROLS, INDICATORS, AND SWITCHES.

This paragraph lists all controls, indicators, and switches used during initial adjustment, alinement, and maintenance of radar set.

4-34. DESCRIPTION OF MAINTENANCE CONTROLS, INDICATORS, AND SWITCHES. (CONT)

PULSE GENERATOR

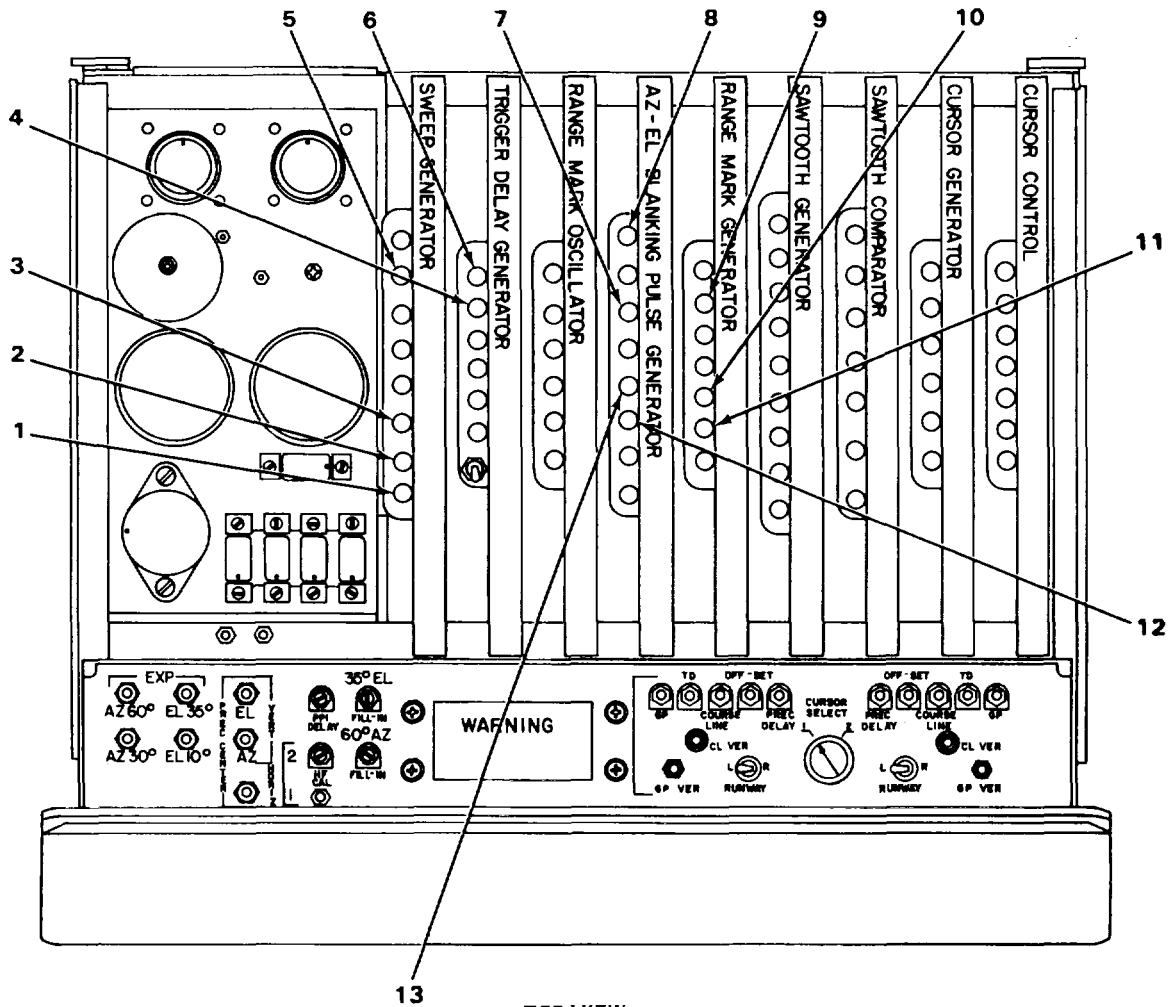

TOP VIEW

305NE101

| KEY | CONTROL OR INDICATOR | DESCRIPTION |
|-----|----------------------|---|
| 1 | R22 PPI SWEEP EXP | Adjusts position of 20-mile range mark on ppi display when RANGE MILES switch is in position 20. |
| 2 | R21 5,10 PREC EXP | Adjusts position of 10-mile range mark on precision approach display when RANGE MILES switch is in position 10. |

4-34. DESCRIPTION OF MAINTENANCE CONTROLS, INDICATORS, AND SWITCHES. (CONT)

| KEY | CONTROL OR INDICATOR | DESCRIPTION |
|-----|----------------------|--|
| 3 | R20 20,40 PREC EXP | Adjusts position of 20-mile range mark on precision approach display when RANGE MILES switch is in position 20. |
| 4 | R35 IFF SWEEP DELAY | Adjusts starting time of IFF sweep. |
| 5 | R3 SWEEP GATE LENGTH | Adjusts length of sweep on crt to the range selected. |
| 6 | R9 RADAR SWEEP DELAY | Adjusts starting time of ppi sweep. |
| 7 | R22 EL SERVO POS | Aligns top edge of blanked sector in range marks representing servo position of elevation antenna to its correct position on azimuth display. |
| 8 | R31 AZ TILT POS | Aligns top edge of blanked sector in range marks representing tilt position of azimuth antenna to its correct position on elevation display. |
| 9 | R4 1 MILE AMPL | Adjusts intensity of range marks when RANGE MILES switch is in position 10. |
| 10 | R23 5 MILE AMPL | Adjusts intensity of range marks when RANGE MILES switch is in position 40. |
| 11 | R41 10 MILE AMPL | Adjusts intensity of range marks when RANGE MILES switch is in position 80. |
| 12 | R37 AZ WIDTH | Orients bottom edge of blanked sector in range marks, which represents tilt position of azimuth antenna to its correct position on elevation display. |
| 13 | R38 EL WIDTH | Orients bottom edge of blanked sector in range marks, which represents servo position of elevation antenna to its correct position on azimuth display. |

4-34. DESCRIPTION OF MAINTENANCE CONTROLS, INDICATORS, AND SWITCHES. (CONT)

PULSE GENERATOR (CONT)

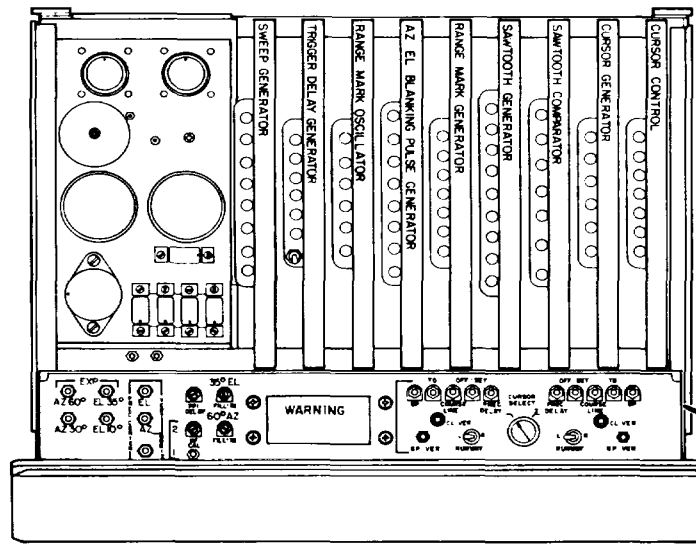

TOP VIEW

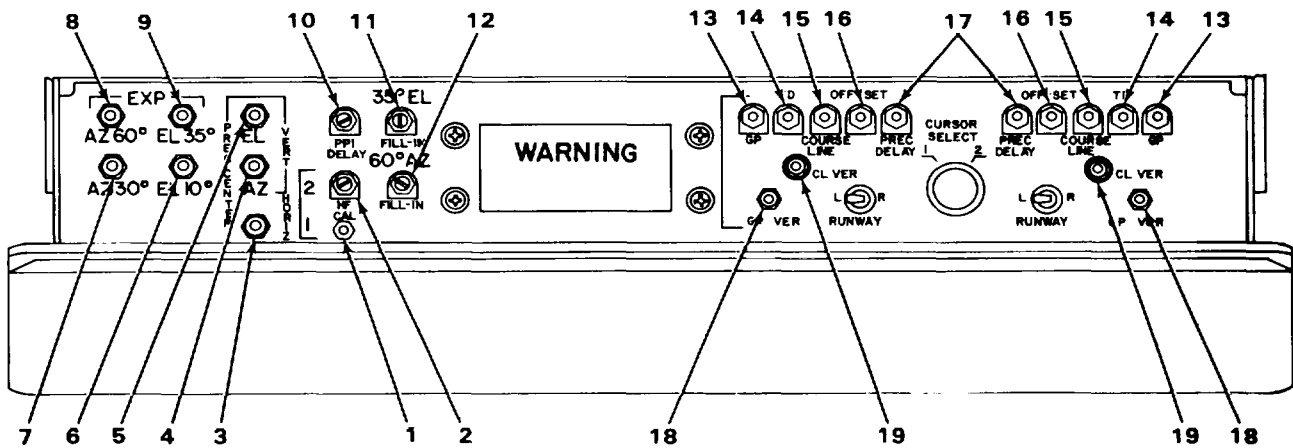

305NE102

| KEY | CONTROL OR INDICATOR | DESCRIPTION |
|-----|----------------------|---|
| 1 | HF CAL 1 | Alines height finder cursor with 2-mile intercept point when EL CURSOR switch is in HF position. |
| 2 | HF CAL 2 | Alines height finder cursor with 10-mile intercept point when EL CURSOR switch is in HF position. |
| 3 | PREC CENTER HORIZ | Adjusts horizontal position of beta scan presentation on crt. |

4-34. DESCRIPTION OF MAINTENANCE CONTROLS, INDICATORS, AND SWITCHES. (CONT)

| KEY | CONTROL OR INDICATOR | DESCRIPTION |
|-----|---------------------------------|---|
| 4 | PREC CENTER VERT AZ | Adjusts vertical position of azimuth scan presentation on crt. |
| 5 | PREC CENTER VERT EL | Adjusts vertical position of elevation scan presentation on crt. |
| 6 | EXP EL 100 | Adjusts vertical size of elevation display when elevation antenna scan is 10 degrees. |
| 7 | EXP AZ 300 | Adjusts vertical size of azimuth display when azimuth antenna scan is 30 degrees. |
| 8 | EXP AZ 600 | Adjusts vertical size of azimuth display when azimuth antenna scan is 60 degrees. |
| 9 | EXP EL 35°0 | Adjusts vertical size of elevation display when elevation antenna scan is 35 degrees. |
| 10 | PPI DELAY | Orients position of range marks in relation to sweep in SEARCH mode of operation. |
| 11 | 350 EL FILL-IN | Adjusts amount of fill-in on elevation display when elevation antenna scan is 35 degrees. |
| 12 | 600 AZ FILL-IN | Adjusts amount of fill-in on azimuth display when azimuth antenna scan is 60 degrees. |
| 13 | GP 1 and GP 2 | Orients elevation cursor to approximate glidepath angle when cursor (1 or 2) is selected. |
| 14 | TD 1 and TD 2 | Adjusts closed-in end of elevation cursor to td point. |
| 15 | COURSE LINE 1 AND COURSE LINE 2 | Adjusts far-out part of azimuth cursor for approximate alinement with clr. |
| 16 | OFF-SET 1 AND OFF-SET 2 | Alines intersection of azimuth cursor and td point with clr. |
| 17 | PREC DELAY 1 AND PREC DELAY 2 | Adjusts starting time of range marks on beta displays to permit adjusting td range mark to target reflectors. |
| 18 | GP VER 1 AND GP VER 2 | Orients elevation cursor to exact glidepath angle. |
| 19 | CL VER 1 AND CL VER 2 | Adjusts far-out portion of elevation cursor for exact alinement with clr. |

4-34. DESCRIPTION OF MAINTENANCE CONTROLS, INDICATORS, AND SWITCHES. (CONT)

CONTROL-INDICATOR

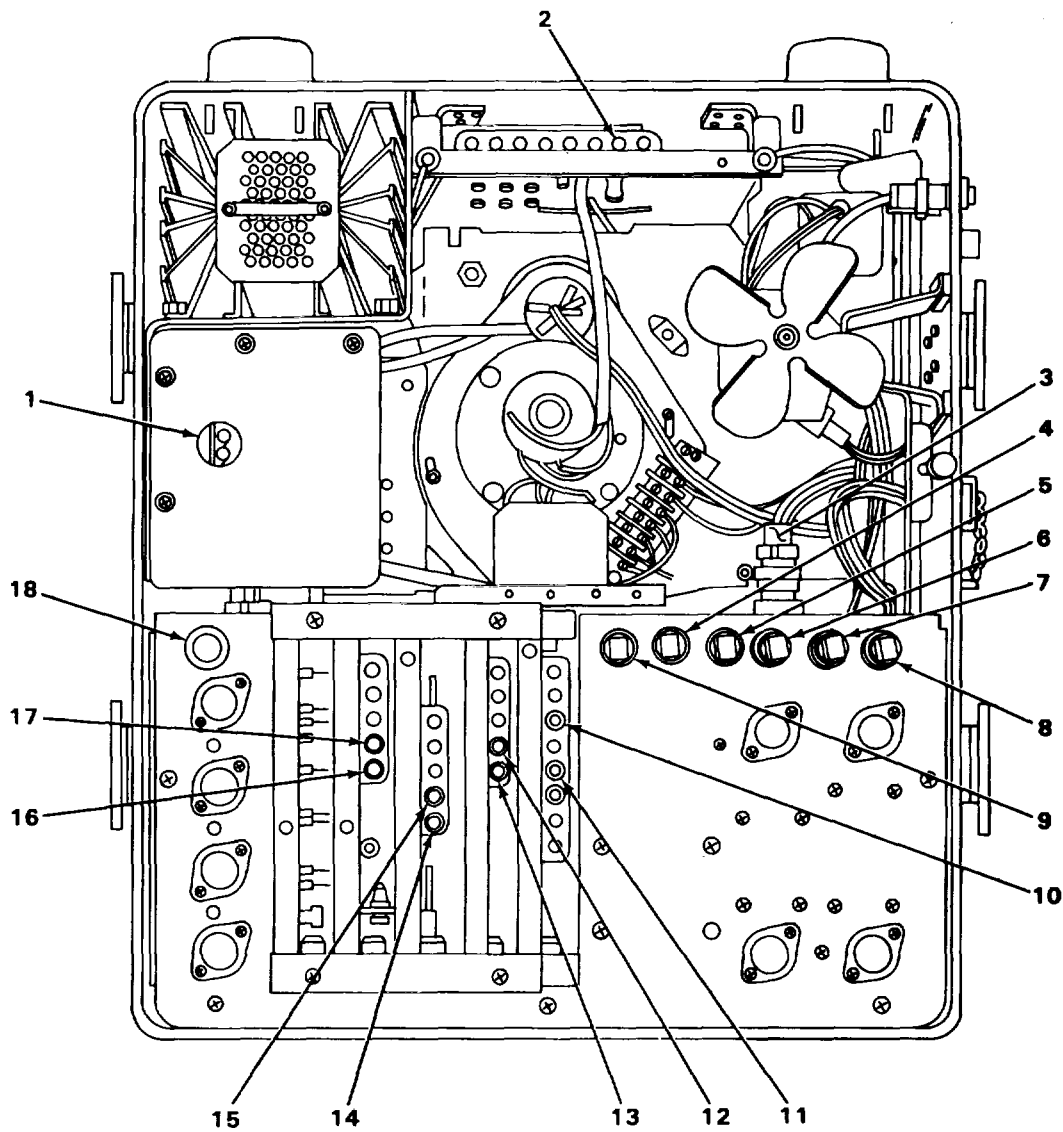

305NE103

| KEY | CONTROL OR INDICATOR | DESCRIPTION |
|-----|----------------------|---|
| 1 | R1632 + 300V ADJ | Adjusts positive output of rotating coil amplifier regulator. |
| 2 | R2201 IFF VIDEO ADJ | Adjusts IFF video output signal from mixer amplifier card. |

4-34. DESCRIPTION OF MAINTENANCE CONTROLS, INDICATORS, AND SWITCHES. (CONT)

| KEY | CONTROL OR INDICATOR | DESCRIPTION |
|-----|-------------------------|--|
| 3 | PPI ORIENT | Orients radar return from target at a known azimuth bearing to correct azimuth bearing on radar display. |
| 4 | F1905 FUSE | 35 v 0.5 amp |
| 5 | F1903 FUSE | 12 v 1.0 amp |
| 6 | F1904 FUSE | -12 v 1.0 amp |
| 7 | F1906 FUSE | - 35 v 0.5 amp |
| 8 | F1901 FUSE | - 28 v 4.0 amp |
| 9 | F1902 FUSE | 6.3 vac 0.5 amp SLO - BLO |
| 10 | R2121 HORIZ CURRENT ADJ | Adjusts horizontal current output of fixed coil amplifier. |
| 11 | R2123 VERT CURRENT ADJ | Adjusts vertical current output of fixed coil amplifier. |
| 12 | R1802 + 12V ADJ | Adjusts positive output of 12V voltage regulator to + 12 v. |
| 13 | R1808 - 12V ADJ | Adjusts negative output of 12V voltage regulator. |
| 14 | R3414 + 35V ADJ | Adjusts positive output of 35V voltage regulator. |
| 15 | R3427 - 35V ADJ | Adjusts negative output of 35V voltage regulator. |
| 16 | R8702 - 18V VERT ADJ | Adjusts negative vertical output of 18V voltage regulator. |
| 17 | R8709 -18V HORZ ADJ | Adjusts negative horizontal output of 18V voltage regulator. |
| 18 | F1907 FUSE | + 450 v 0.25 amp |

4-34. DESCRIPTION OF MAINTENANCE CONTROLS, INDICATORS, AND SWITCHES. (CONT)

CONTROL-INDICATOR (CONT)

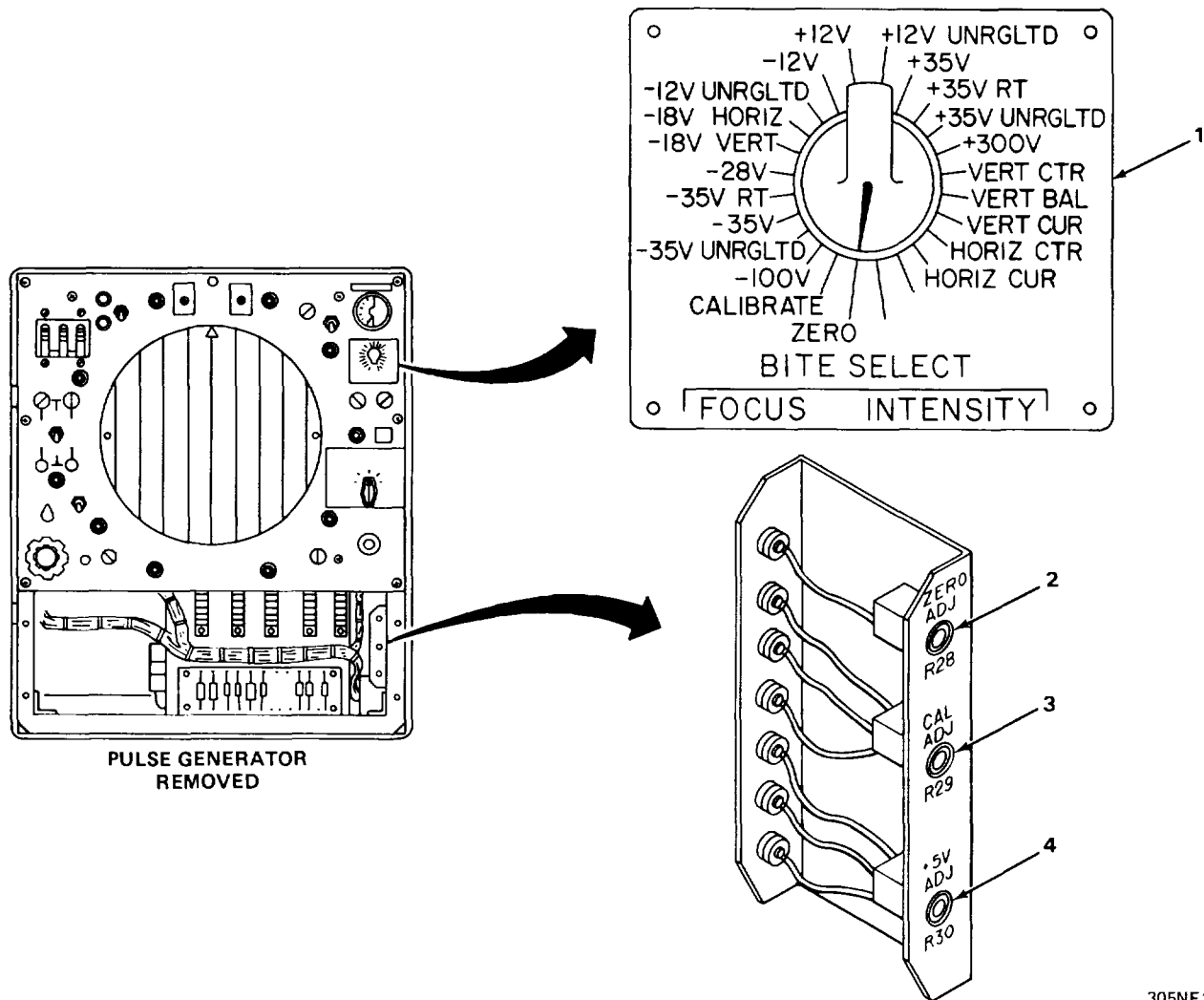

305NE104

| KEY | CONTROL OR INDICATOR | DESCRIPTION |
|-----|----------------------|---|
| 1 | BITE SELECT | Twenty-four position switch selects receiver-transmitter low-voltage power supplies and antenna data to be monitored on AZ TILT/BITE METER. |
| 2 | R28 ZERO ADJ | Centers AZ TILT/BITE meter when BITE SELECT switch is in ZERO position. |
| 3 | R29 CAL ADJ | Adjusts AZ TILT/BITE meter for full-scale deflection when BITE SELECT switch is in BITE position. |
| 4 | R30 + 5V ADJ | Adjusts voltage applied to AZ TILT/BITE meter to + 5 v. |

4-34. DESCRIPTION OF MAINTENANCE CONTROLS, INDICATORS, AND SWITCHES. (CONT)

RECEIVER-TRANSMITTER

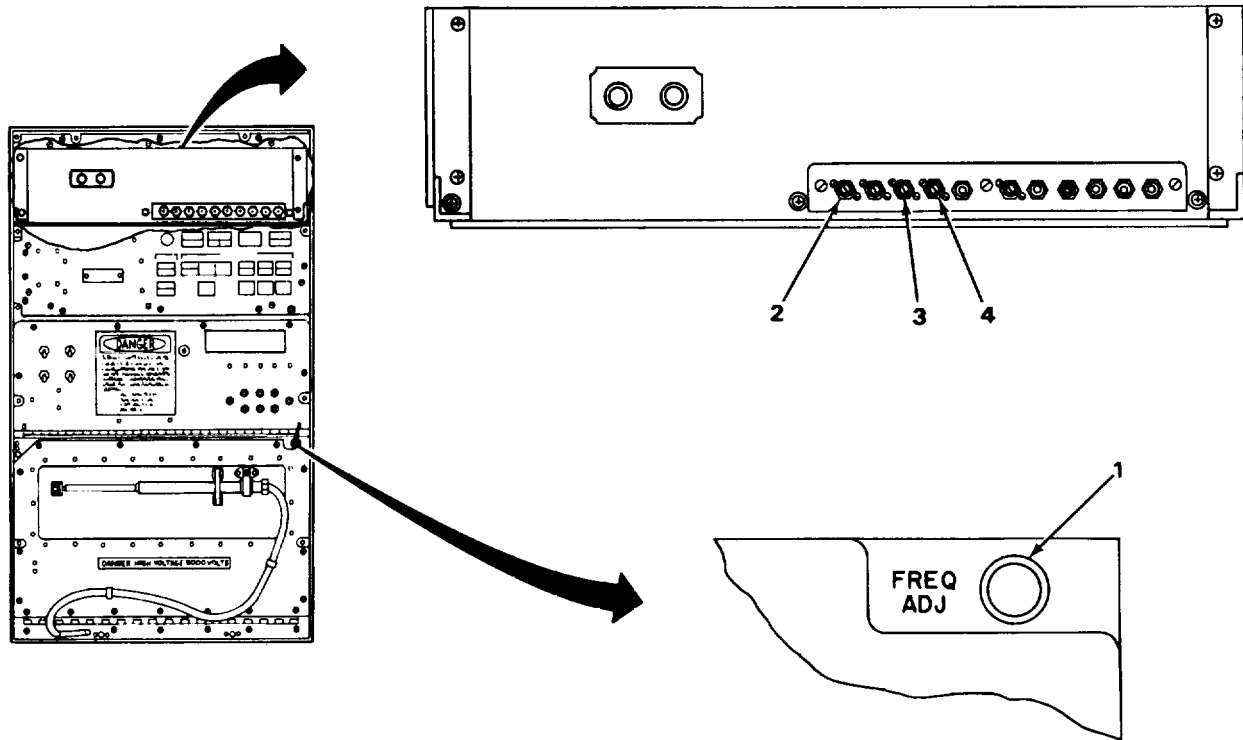

305NE105

| KEY | CONTROL OR INDICATOR | DESCRIPTION |
|-----|----------------------|--|
| 1 | MAGNETRON FREQ ADJ | Mechanical adjustment of magnetron frequency. |
| 2 | R59 SEARCH RPM | Adjusts rotational speed of azimuth antenna in SEARCH mode of operation. |
| 3 | R63 AZ ATTEN | Adjusts azimuth attenuator voltage. |
| 4 | R64 EL ATTEN | Adjusts elevation attenuator voltage. |

4-34. DESCRIPTION OF MAINTENANCE CONTROLS, INDICATORS, AND SWITCHES. (CONT)

RECEIVER-TRANSMITTER (CONT)

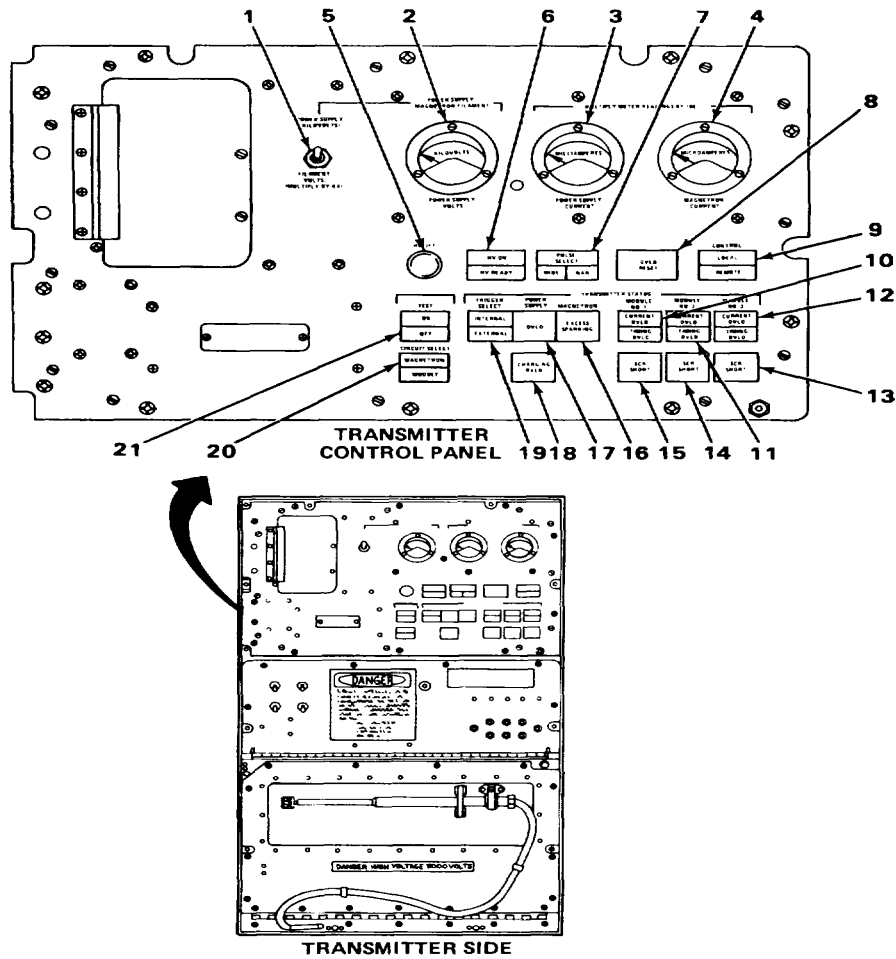

305NE106

| KEY | CONTROL OR INDICATOR | DESCRIPTION |
|-----|---|---|
| 1 | POWER SUPPLY/FILAMENT VOLTS switch | Two-position switch selects either high-voltage power supply voltage or magnetron filament voltage to be monitored on POWER SUPPLY/MAGNETRON VOLTS meter. |
| 2 | POWER SUPPLY/MAGNETRON FILAMENT VOLTS meter | Monitors either high-voltage power supply or magnetron filament voltage as selected by POWER SUPPLY/FILAMENT VOLTS switch. |

4-34. DESCRIPTION OF MAINTENANCE CONTROLS, INDICATORS, AND SWITCHES. (CONT)

| KEY | CONTROL OR INDICATOR | DESCRIPTION |
|-----|---|--|
| 3 | POWER SUPPLY CURRENT meter | Indicates current drain of high-voltage power supply. |
| 4 | MAGNETRON CURRENT meter | Indicates average magnetron current. |
| 5 | HV OFF switch | When depressed, removes control voltage that turns off high-voltage power supply. |
| 6 | HV ON-HV READY indicator switch | Two-position indicator switch indicates high-voltage power supply is in standby (HV READY) or is transmitting (HV ON). When switch is depressed, appropriate section will light. |
| 7 | PULSE SELECT WIDE/NAR indicator switch | Two-position indicator switch indicates wide pulse or narrow pulse mode of local operation when applicable section is depressed. |
| 8 | OVLD RESET indicator switch | Switch is lit when overload is present in transmitter. When depressed, resets all overloads in transmitter. |
| 9 | CONTROL LOCAUREMOTE indicator switch | Two-position indicator switch allows local (transmitter site) or remote (control-indicator site) operation of transmitter, when appropriate section is depressed. |
| 10 | MODULE NO. 1 CURRENT OVLD-TIMING OVLD indicator | Two-section fault indicator that monitors performance of three modular boards. CURRENT OVLD lights when an excessive modular current is present. TIMING OVLD lights when a modular trigger is missing. |
| 11 | MODULE NO. 2 CURRENT OVLD-TIMING OVLD indicator | Same as MODULE NO. 1 CURRENT OVLD-TIMING OVLD indicator. |
| 12 | MODULE NO. 3 CURRENT OVLD-TIMING OVLD indicator | Same as MODULE NO. 1 CURRENT OVLD-TIMING OVLD indicator. |
| 13 | MODULE NO. 3 SCR SHORT indicator | Same as MODULE NO. 1 SCR SHORT indicator. |
| 14 | MODULE NO. 2 SCR SHORT indicator | Same as MODULE NO. 1 SCR SHORT indicator. |
| 15 | MODULE NO. 1 SCR SHORT indicator | Lights when scr on modular board shorts or when no pulse forming network (PFN) voltage is detected during PFN charging time. |

4-34. DESCRIPTION OF MAINTENANCE CONTROLS, INDICATORS, AND SWITCHES. (CONT)

RECEIVER-TRANSMITTER (CONT)

| KEY | CONTROL OR INDICATOR | DESCRIPTION |
|-----|---|--|
| 16 | MAGNETRON EXCESS SPARKING indicator | Illuminates when magnetron arcing (sparking) occurs. |
| 17 | POWER SUPPLY OVLD Indicator | Illuminates when high-voltage power supply current overload occurs. |
| 18 | CHARGING OVLD indicator | Illuminates when pfn charging overload occurs. |
| 19 | TRIGGER SELECT INTERNAL-EXTERNAL indicator switch | Two-position indicator switch allows selection of internally generated trigger or externally generated trigger from IFF system for transmitter operation. |
| 20 | CIRCUIT SELECT MAGNETRON-MODULE indicator switch | Two-position indicator switch allows application of test signals to magnetron fault circuits or modulator fault circuits when TEST indicator switch is in ON position. |
| 21 | TEST ON-OFF indicator switch | When ON section is depressed, allows test signals to be applied to fault circuits. |

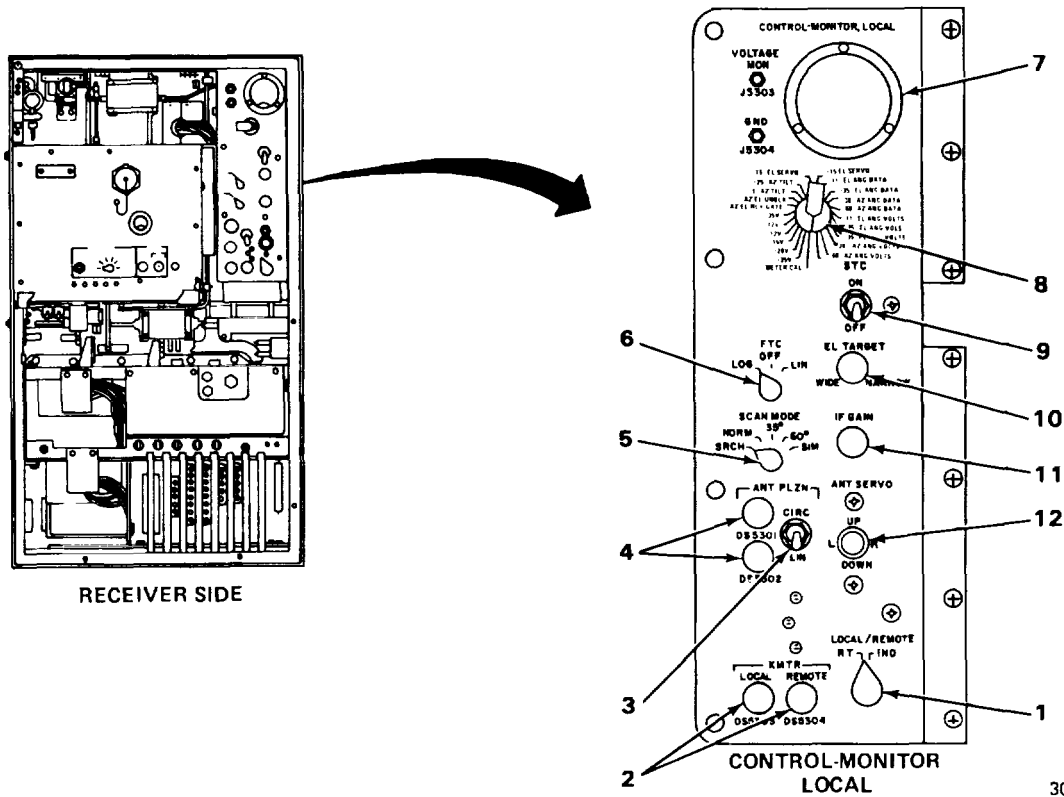

305NÉ107

4-34. DESCRIPTION OF MAINTENANCE CONTROLS, INDICATORS, AND SWITCHES. (CONT)

| KEY | CONTROL OR INDICATOR | DESCRIPTION |
|-----|---------------------------------------|--|
| 1 | LOCAL/REMOTE switch | Two-position switch, when placed in RT position, allows control of receiver and antenna scan and polarization functions from receiver-transmitter site. When in IND position, functions controlled from control-indicator site. |
| 2 | XMTR LOCAUREMOTE indicators | XMTR LOCAL indicator lights when LOCAUREMOTE switch is in RT position. XMTR REMOTE indicator lights when LOCAUREMOTE switch is in IND position. |
| 3 | ANT PLZN switch | Two-position switch selects either circular or linear polarization when in local mode of operation (LOCAL/REMOTE switch in RT position). |
| 4 | DS5301 and DS5302 ANT PLZN indicators | DS5301 indicator lights when circular mode of polarization is selected at receiver-transmitter or control-indicator site. DS5302 indicator lights when linear mode of polarization is selected. |
| 5 | SCAN MODE switch | Five-position switch selects any of five modes of antenna scan operation when in local mode of operation. |
| | FTC switch | Three-position switch selects linear (LIN) ftc or logarithmic (LOG) ftc video. In OFF position, ftc video output circuit is disabled and video is amplified linearly. Ftc switch is used to break up video clutter while in local mode of operation. |
| 7 | MONITOR meter | Monitors various BITE signals as selected by MONITOR switch in local mode of operation. |
| 8 | MONITOR switch | Twenty-four position switch selects receiver-transmitter low-voltage power supply and antenna data to be indicated on MONITOR meter, when in local mode of operation. |
| 9 | STC switch | In ON position, reduces receiver gain for radar targets at close ranges. Used during local mode of operation. |
| 10 | EL TARGET control | Adjusts monopulse operation of receiver in local mode of operation. When rotated clockwise, targets and ground clutter become narrower in vertical plane on elevation display. |
| 11 | IF GAIN control | Controls receiver gain for five types of antenna scan operation while in local mode of operation. |
| 12 | ANT SERVO switch | Four-position switch controls azimuth antenna tilt and elevation antenna servo position when in local mode. |

4-34. DESCRIPTION OF MAINTENANCE CONTROLS, INDICATORS, AND SWITCHES. (CONT)

RECEIVER-TRANSMITTER (CONT)

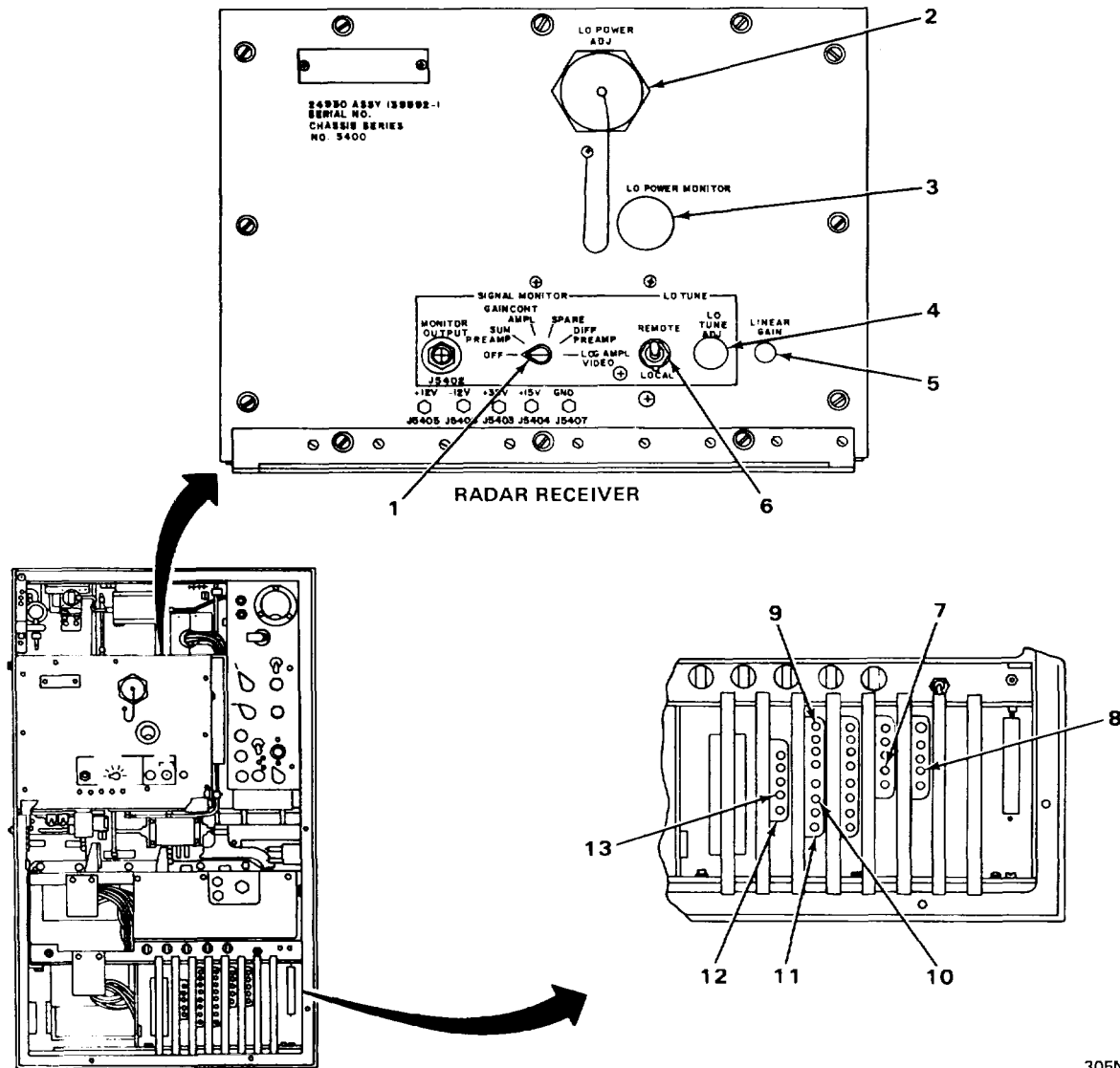

305NE108

| KEY | CONTROL OR INDICATOR | DESCRIPTION |
|-----|-----------------------|--|
| 1 | SIGNAL MONITOR switch | Six-position switch used to monitor preamplifier and amplifier signals produced in receiver. |
| 2 | LO POWER ADJ | Adjusts power output of local oscillator when receiver is in local mode of operation. |

4-34. DESCRIPTION OF MAINTENANCE CONTROLS, INDICATORS, AND SWITCHES. (CONT)

| KEY | CONTROL OR INDICATOR | DESCRIPTION |
|-----|-----------------------------|---|
| 3 | LO POWER MONITOR meter | Monitors power output of local oscillator when receiver is in local mode of operation. |
| 4 | LO TUNE ADJ control | Tunes frequency of local oscillator when receiver is in local mode of operation. |
| 5 | LINEAR GAIN control | Adjusts gain of lin/log i-f amplifier when receiver is in local mode of operation. |
| 6 | LO TUNE REMOTE/LOCAL switch | Two-position switch when in LOCAL position allows tuning of local oscillator from receiver-transmitter site. In REMOTE position, local oscillator is tuned from control-indicator site. |
| 7 | R710 OFFSET CONTROL | Adjusts voltage output of elevation electronic filter card to OV. |
| 8 | R710 OFFSET CONTROL | Adjusts voltage output of azimuth electronic filter card to OV. |
| 9 | R8 AC GAIN | Adjusts sensitivity of azimuth servo drive motor (azimuth antenna drive). |
| 10 | R58 FINE BAL | Provides fine adjustment to balance two outputs of electronic control preamplifier to be applied to electronic control amplifier. |
| 11 | R46 COARSE BAL | Provides coarse adjustment to balance two outputs of electronic control preamplifier to be applied to electronic control amplifier. |
| 12 | + 35V ADJ | Adjusts positive output of 35V voltage regulator. |
| 13 | - 35V ADJ | Adjusts negative output of 35V voltage regulator. |

4-34. DESCRIPTION OF MAINTENANCE CONTROLS, INDICATORS, AND SWITCHES. (CONT)

RECEIVER - TRANSMITTER (CONT)

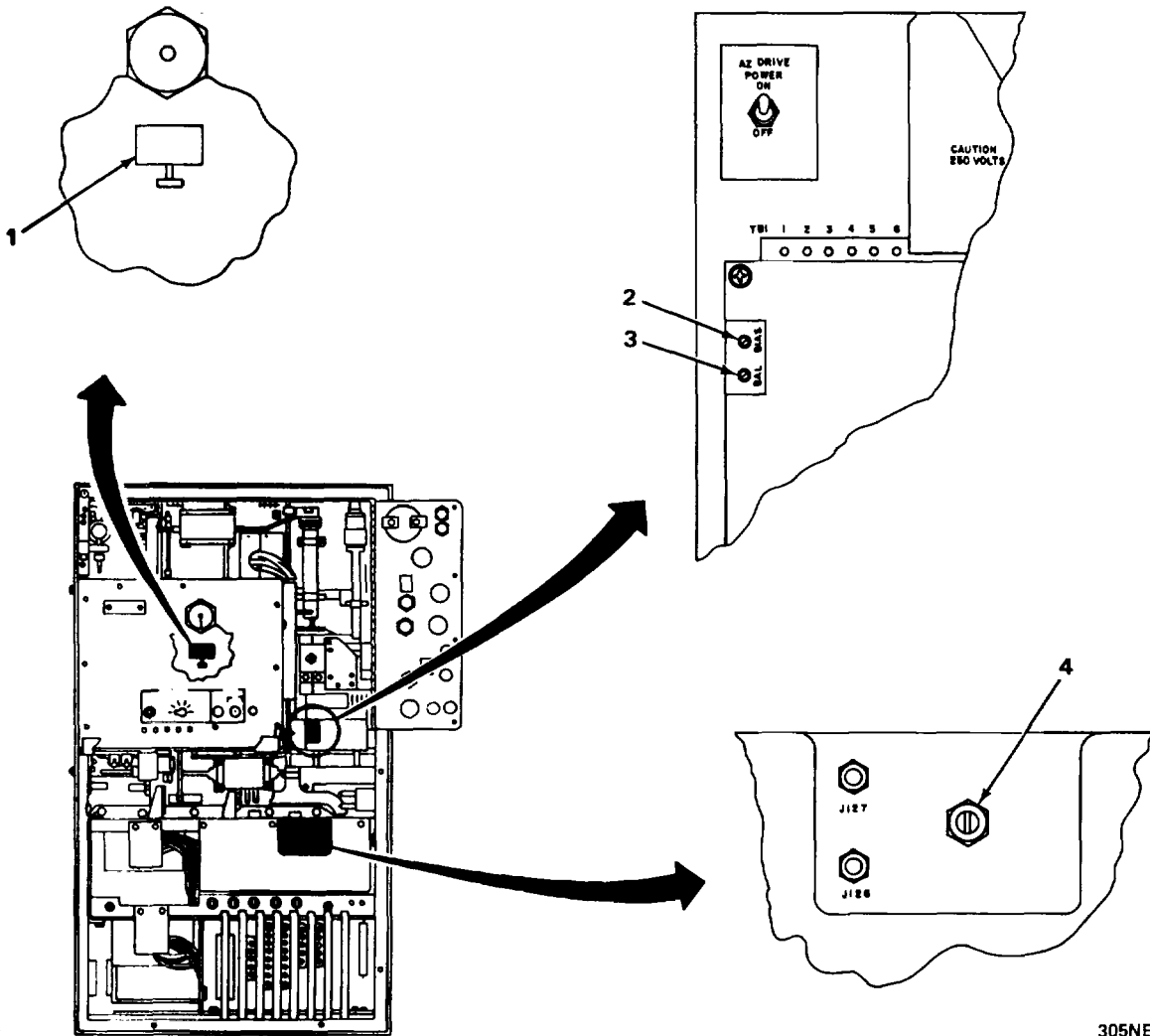

305NE109

| KEY | CONTROL OR INDICATOR | DESCRIPTION |
|-----|----------------------|--|
| 1 | LOCAL OSC ADJ | Adjusts frequency of local oscillator. |
| 2 | BIAS ADJ | Adjusts bias voltage of electronic control amplifier. |
| 3 | BAL ADJ | Balances bias voltage of electronic control amplifier. |
| 4 | R104 FERRITE CONTROL | Regulates voltage supplied to ferrite switch. |

4-35. DEHYDRATOR CARTRIDGE REPLACEMENT.

Three dehydrator cartridges are installed in waveguides of radar set. The procedure below is typical for removal and replacement of all dehydrator cartridges. NSN for replacement cartridges can be found in TM 11-5840-281-20P.

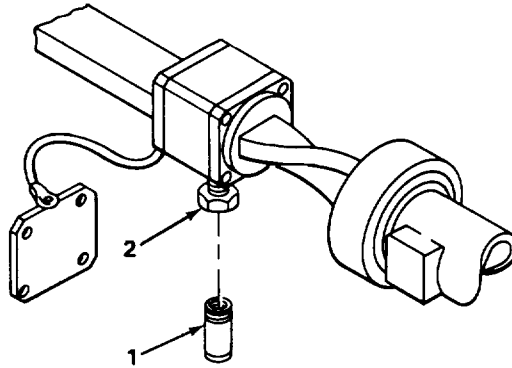

305NE170

REMOVAL**NOTE**

Do not remove dehydrator cartridge adapter when replacing dehydrator cartridges.

Unscrew dehydrator cartridge (1) from dehydrator cartridge adapter (2).

REPLACEMENT

Install new dehydrator cartridge (1) by screwing into dehydrator cartridge adapter (2).

4-36. AIR FILTER CLEANING AND SERVICING.

There are four air filters: one in bottom of receiver-transmitter, one in receiver side cover of receiver-transmitter, and one in bottom front of each pulse generator. These should be cleaned at regular intervals specified in organizational PMCS table. Clean air filters as described below.

4-36. AIR FILTER CLEANING AND SERVICING. (CONT)

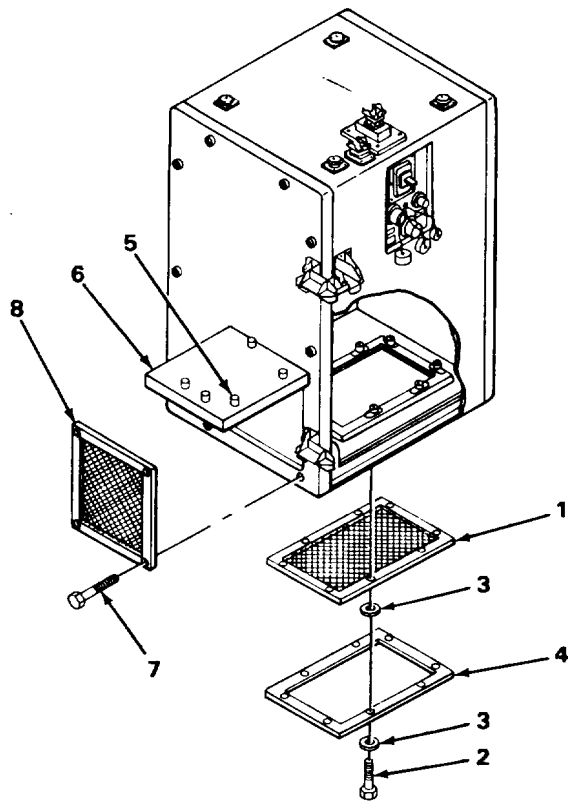

305NE214

1. Identify and remove air filter (1) from bottom of receiver-transmitter by removing eight screws (2) and 16 flat washers (3) from filter baffle (4). Air filter will drop down free from equipment.
2. Loosen seven captive head screws (5) and open filter hood door (6).
3. Remove 12 screws (7) securing air filter (8) and remove filter.

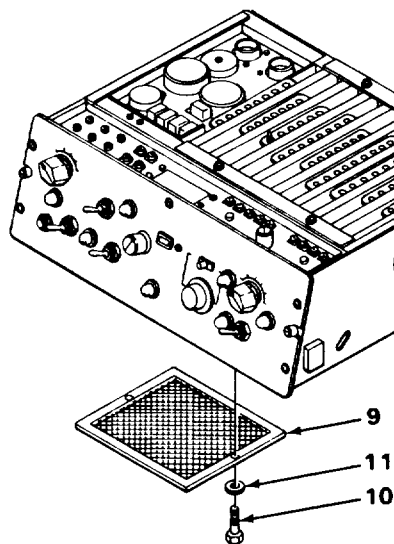

305NE215

4-36. AIR FILTER CLEANING AND SERVICING. (CONT)

4. Remove air filter (9) from bottom of both pulse generators by removing two screws (10) and two flat washers (11). Air filter will drop down from equipment.
5. Tap edges of air filters to remove as much dirt as possible.

WARNING**TRICHLOROTRIFLUOROETHANE**

Fumes of TRICHLOROTRIFLUOROETHANE are poisonous. Provide adequate ventilation whenever you use TRICHLOROTRIFLUOROETHANE. Do not use solvent near heat or open flame. TRICHLOROTRIFLUOROETHANE will not burn, but heat changes the gas into poisonous, irritating fumes. DO NOT breathe the fumes or vapors. TRICHLOROTRI-FLUOROETHANE dissolves natural skin oils. DO NOT get the solvent on your skin. Use gloves, sleeves, and an apron which the solvent cannot penetrate. If the solvent is taken internally, consult a physician immediately.

6. Wash air filters in trichlorotrifluoroethane, using brush to remove dirt from wire mesh.
7. Allow filters to drain by supporting on suitable surface with airflow arrows on sides of filters pointing upward.
8. Reinstall air filters in appropriate locations with airflow arrows pointing into equipment.

4-37. CONTROL KNOB REPLACEMENT.

This procedure is typical for replacement of all control knobs on radar set. NSNs for replacement knobs can be found in TM 11-5840-281-20P.

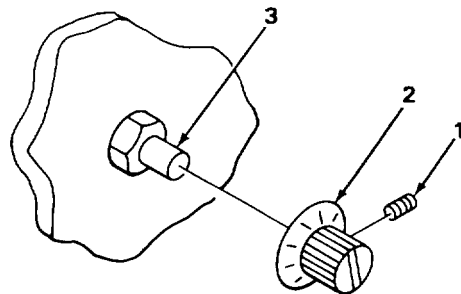

305NE175

REMOVAL

1. Loosen setscrew(s) (1) inside of knob (2).
2. Note position of indicating mark on knob (2). If any exists, and slide knob (2) off of shaft (3).

4-38. TRANSMITTER CONTROL PANEL LAMP REPLACEMENT.

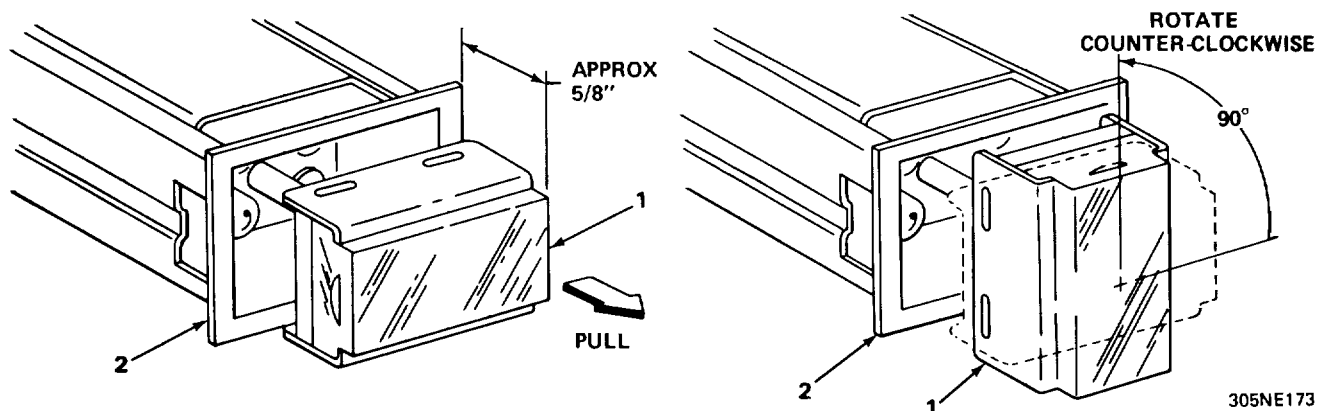

REMOVAL

1. Using fingernail slots on side of lens, pull lens/diffuser assembly (1) approximately 5/8 inch out of indicator housing (2) and rotate 90 degrees counterclockwise.
2. Push lens/diffuser assembly (1) in and remove from indicator housing (2).

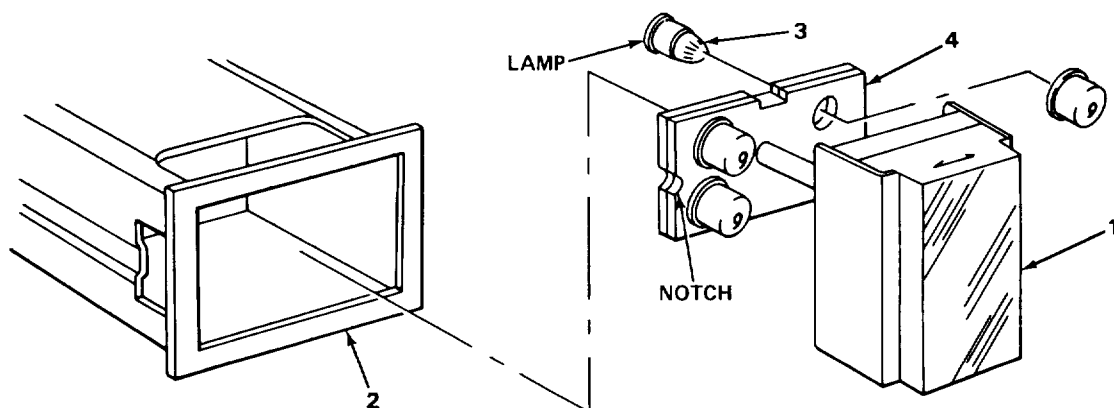

3. Remove defective lamp (3) from lamp mounting board (4).

REPLACEMENT

1. Insert new lamp (3) in mounting board (4).
2. Align notch with key in housing.
3. Push lens/diffuser assembly (1) into indicator housing (2) and rotate 90 degrees clockwise to engage contacts.
4. Push lens/diffuser assembly (1) gently until it is flush with panel.

4-39. PLUG-IN CIRCUIT CARD REPLACEMENT.

This procedure is typical for removal and replacement of plug-in circuit cards located in control-indicator and receiver-transmitter power supplies. NSNs for replacement cards can be found in TM 11-5840-281-20P.

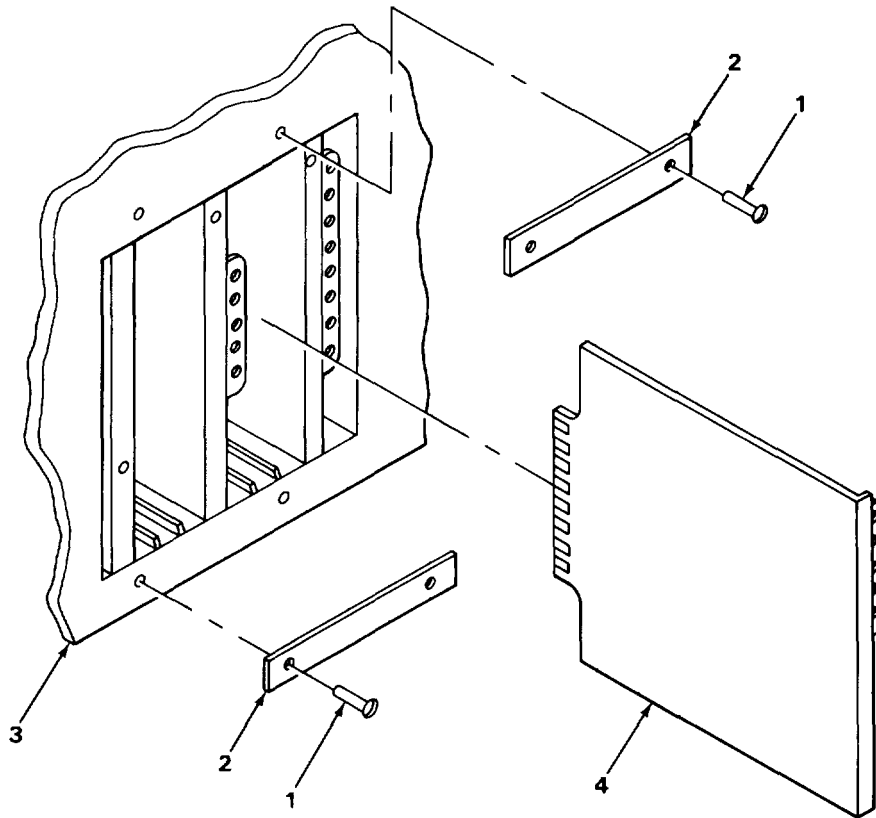

305NE176

REMOVAL

1. Turn off power from unit with defective card.
2. Remove four screws (1) securing retaining straps (2) to card cage (3) and remove retaining straps.
3. Remove defective circuit card (4).

REPLACEMENT

1. Insert new circuit card (4).
2. Using four screws (1), secure retaining straps (2) to card cage (3).
3. Perform applicable power supply alignment procedure.

4-40. RECEIVER-TRANSMITTER LOW VOLTAGE POWER SUPPLY REPLACEMENT.

PRELIMINARY PROCEDURE: Turn power source off.

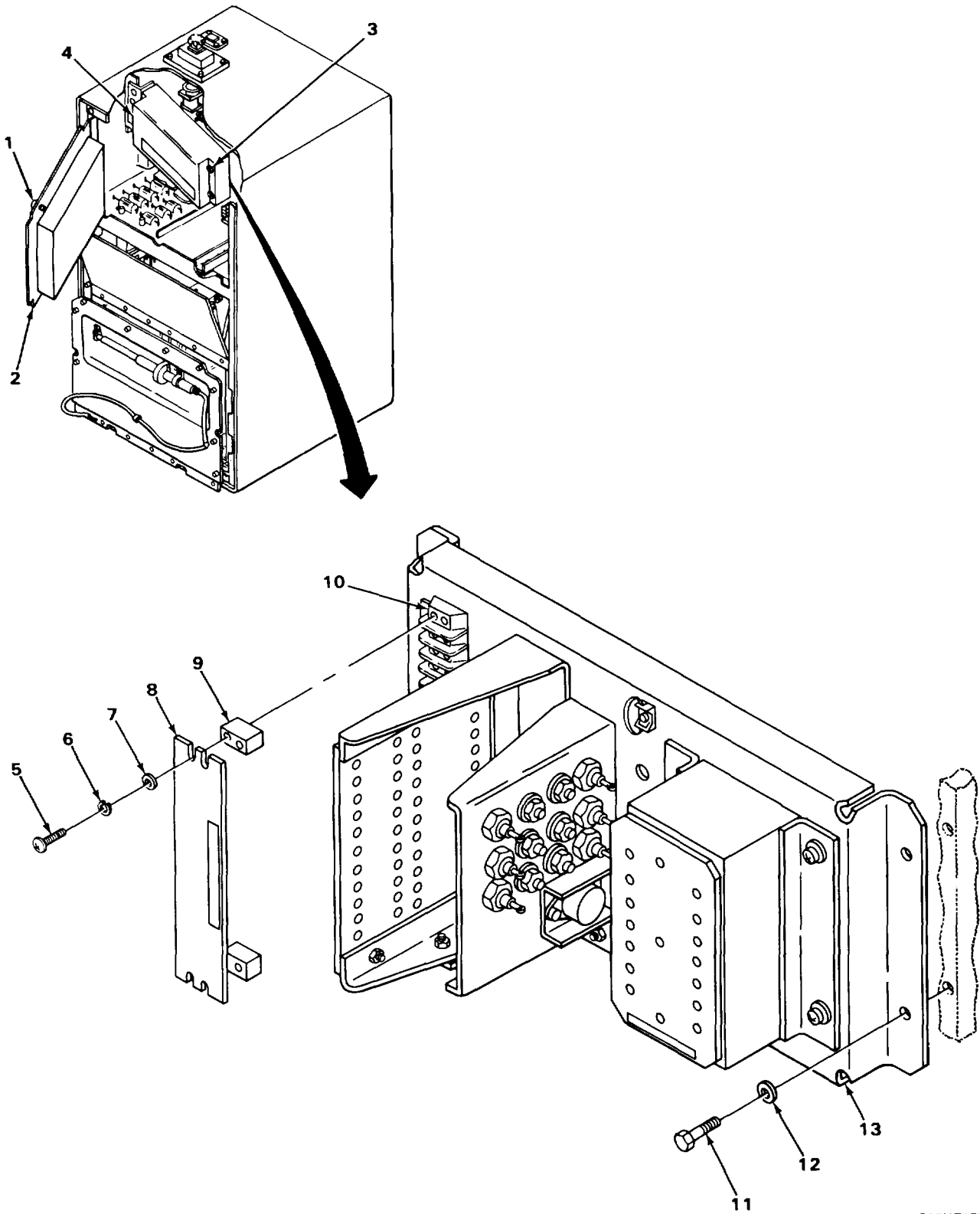

305NE177

4-40. RECEIVER-TRANSMITTER LOW VOLTAGE POWER SUPPLY REPLACEMENT. (CONT)

REMOVAL

1. Open transmitter door.
2. Loosen eight spring-loaded screws (1) on transmitter control panel (2) and open panel.
3. Loosen four spring-loaded screws (3) on remote switching control (4) and open control.
4. Remove four screws (5), lockwashers (6), and flat washers (7) on designation plate (8).
5. Remove spacer (9) and designation plate (8) from terminal board TB 1 (10).
6. Tag and remove all wires on left side of terminal board TB 1 (10).
7. Remove four bolts (11) and flat washers (12) from low-voltage power supply (13).
8. Remove low-voltage power supply (13).

REPLACEMENT

1. Place low-voltage power supply (13) into mounting position.
2. Install four bolts (11) and flat washers (12) to secure low-voltage power supply (13).
3. Connect the corresponding wires on left side of terminal board TB 1 (10).
4. Place spacer (9) between designation plate (8) and terminal board TB 1 (10).
5. Using four screws (5), lockwashers (6), and flat washers (7), secure designation plate (8).
6. Close remote switching control (4) and, using four spring-loaded screws (3), secure.
7. Close transmitter control panel (2) and, using eight spring-loaded screws (1), secure.
8. Close transmitter door and lock.
9. Turn on power.

4-41. RECEIVER-TRANSMITTER POWER SUPPLY ADJUSTMENT.

Set up multimeter to measure voltages specified in the following table. Adjust voltage level as necessary by adjusting indicated control. If adjustments cannot be accomplished, or if unadjustable voltages are not within tolerances indicated, refer to a higher category of maintenance.

PRELIMINARY PROCEDURE: Place SCAN switch on receiver-transmitter main power panel to OFF position.

| MULTIMETER TEST LEAD CONNECTION | | LOCATION | CONTROL | INDICATION |
|---------------------------------|-------------------|--|--|-------------|
| POSITIVE LEAD | NEGATIVE LEAD | | | |
| + 28 V J141 | LVPS COM | Transmitter Control Panel | Not Adjustable | +28 + 4 V |
| + 12 V J140 | LVPS COM | Transmitter Control Panel | Not Adjustable | +12 + 0.6 V |
| LVPS COM | - 19 V J137 | Transmitter Control Panel | Not Adjustable | -19 + 1.5 V |
| LVPS COM | - 6 V J138 | Transmitter Control Panel | Not Adjustable | -6 + 0.3V |
| GND 5304 | VOLTAGE MON J5303 | Local Control Monitor and Place MONITOR Switch to - 35V Position | R3427-35 ADJ on 35V Voltage Regulator Card | - 35 V |

4-41. RECEIVER-TRANSMITTER POWER SUPPLY ADJUSTMENT. (CONT)

| MULTIMETER TEST LEAD CONNECTION | | LOCATION | CONTROL | INDICATION |
|---------------------------------|----------------------|---|--|---------------|
| POSITIVE LEAD | NEGATIVE LEAD | | | |
| VOLTAGE MON J5303 | GND J5304 | Local Control Monitor and Place MONITOR Switch to + 35V Position | R3414 + 35 V ADJ on 35V Voltage Regulator Card | + 35 V |
| VOLTAGE MON J5303 | GND J5304 | Local Control Monitor and Place MONITOR Switch to + 28V Position | Not Adjustable | + 28 + 4 V |
| VOLTAGE MON J5303 | GND J5304 | Local Control Monitor and Place MONITOR Switch to + 15V Position | Not Adjustable | + 15 + 0.15 V |
| VOLTAGE MON J5303, | GND J5304 | Local Control Monitor and Place MONITOR Switch to + 12V Position | Not Adjustable | + 12+ 0.12 V |
| GND J5304 | VOLTAGE MON J5303 | Local Control Monitor and Place MONITOR Switch to - 12V Position | Not Adjustable | -12 + 0.12V |

NOTE

When voltage measurements are complete, place SCAN switch on receiver-transmitter main power panel to ON position.

4.42. CONTROL-INDICATOR POWER SUPPLY ADJUSTMENT.

Set up multimeter to measure voltages specified in the following table. Adjust voltage level as necessary by adjusting indicated control. If adjustments cannot be accomplished, or if unadjustable voltages are not within tolerances indicated, refer to a higher category of maintenance.

PRELIMINARY PROCEDURE: Place BITE-AZ TILT switch category to BITE position.

| MULTIMETER TEST LEAD CONNECTION | | LOCATION | CONTROL | INDICATION |
|---------------------------------|---------------|--|----------------|------------|
| POSITIVE LEAD | NEGATIVE LEAD | | | |
| DC RET J616 | BITE MON J615 | Control-Indicator and Place BITE SELECT Switch to - 100V Position | Not Adjustable | -100 + 5 V |

4-42. CONTROL-INDICATOR POWER SUPPLY ADJUSTMENT. (CONT)

| MULTIMETER TEST LEAD CONNECTION | | LOCATION | CONTROL | INDICATION |
|---------------------------------|----------------|--|---|--------------|
| POSITIVE LEAD | NEGATIVE LEAD | | | |
| BITE MON J615 | DC RET J616 | Control-Indicator and Place BITE SELECT Switch to + 300V Position | R1632 + 300V ADJ on Rotating Coil Amplifier | + 300 V |
| BITE MON J615 | DCRETJ616 | Control-Indicator and Place BITE SELECT Switch to + 35V Position | R3414 +35VADJ on 35V Voltage Regulator Card | +35V |
| DC RET J616 | BITE MON J615 | Control-indicator and Place BITE SELECT Switch to - 35V Position | R3427 -35VADJ on 35V Voltage Regulator Card | -35V |
| DC RET J616 | BITE MON J615 | Control-Indicator and Place BITE SELECT Switch to - 12V Position | R1808 -12V ADJ on 12V Voltage Regulator Card | -12 V |
| BITE MON J615 | DC RETJ616 | Control-Indicator and Place BITE SELECT Switch to + 12V Position | R1802 + 12VADJ on 12V Voltage Regulator Card | +12V |
| DC RET J616 | BITE MON J615 | Control-Indicator and Place BITE SELECT Switch to - 18V HORIZ Position | R8709 -18V HORIZ ADJ on -18V Voltage Regulator Card | - 18 V |
| DC RET J616 | BITE MON J615 | Control-Indicator and Place BITE SELECT Switch to - 18 VERT Position | R8702 -18V VERT ADJ on - 18V Voltage Regulator Card | -18V |
| DC RET J616 | BITE MON J615 | Control-Indicator and Place BITE SELECT Switch to -28V Position | Not Adjustable | - 28 : 3 V |
| + 450 V TP1903 | CKT GRD TP1901 | Indicator Power Supply | Not Adjustable | + 450:t 30 V |

4-43. ELEVATION ELECTRONIC FILTER ALINEMENT.

1. On master pulse generator, place SCAN switch to OFF position.
2. On both pulse generators, place SCAN MODE switch to NORM position and place ANGLE VOLTS switch to OPERATE position.
3. On receiver-transmitter main power panel, place SCAN switch to OFF position.
4. On transmitter control panel, depress LOCAL section of LOCAL-REMOTE indicator switch.
5. Install clinometer on elevation antenna clinometer mount, Clinometer installation (para 421).
6. Manually position elevation antenna to - 1 degree as indicated on clinometer.
7. Set up multimeter to measure any positive dc voltage.

4-43. ELEVATION ELECTRONIC FILTER ALINEMENT. (CONT)

8. On elevation electronic filter in pulse generator, connect positive lead of multimeter to ANGLE VOLTS J703 and connect negative lead to GND 701.
9. On elevation electronic filter in pulse generator, adjust OFFSET control J710 to obtain exact OV indication on multimeter.
10. Disconnect test leads.
11. On receiver-transmitter main power panel, place SCAN switch to ON position.
12. On transmitter control panel, press REMOTE section of LOCAL-REMOTE indicator switch.

4-44. AZIMUTH ELECTRONIC FILTER ALINEMENT.

1. On master pulse generator, place SCAN switch to OFF position.
2. On both pulse generators, place SCAN MODE switch to NORM position and place ANGLE VOLTS switch to OPERATE position.
3. On receiver-transmitter main power panel, place SCAN switch to OFF position.
4. On transmitter control panel, press LOCAL section of LOCAL-REMOTE indicator switch.
5. Manually position azimuth antenna to + 15 degrees as indicated on azimuth scan protractor.
6. Set up multimeter to measure any positive dc voltage.
7. On azimuth electronic filter in pulse generator, connect positive lead of multimeter to ANGLE VOLTS J703 and connect negative lead to GND J701.
8. On azimuth electronic filter in pulse generator, adjust OFFSET control J710 to obtain exact OV indication on multimeter.
9. Disconnect test leads.
10. On receiver-transmitter main power panel, place SCAN switch to ON position.
11. On transmitter control panel, press REMOTE section of LOCAL-REMOTE indicator switch.

4-45. FIXED COIL AMPLIFIER ADJUSTMENT.

PERSONNEL REQUIRED: Two

NOTE

Unless otherwise indicated, perform the following steps on control-indicator where fixed coil amplifier adjustment is being performed.

1. On master pulse generator, place SCAN MODE switch to SEARCH position.
2. On control-indicator, place BITE-AZ TILT switch to BITE position and place BITE SELECT switch to HORIZ CURR position.
3. On control-indicator, place NORM-OFFSET switch to OFFSET position.
4. On fixed coil amplifier, adjust R2128 HORIZ CURRENT ADJ, R2123 VERT CURRENT ADJ, and R2109 VERT BAL ADJ to mid position.
5. On control-indicator, place BITE SELECT switch to VERT CTR position.
6. On control-indicator, adjust VERT control on PPI CENTERING controls for center scale indication on AZ TILT/BITE meter.

4-46. AZIMUTH ANTENNA SCAN ADJUSTMENT.

TOOLS: Stopwatch or wristwatch capable of measuring seconds

PERSONNEL REQUIRED: Two

PRELIMINARY PROCEDURE: Perform preliminary control setting (para 3-6).

1. On local control monitor, place LOCAUREMOTE switch to RT position and SCAN MODE switch to
2. On receiver-transmitter main power panel, place SCAN switch to OFF position.
3. On preamp control card, in receiver-transmitter, adjust R8 AC GAIN control clockwise until azimuth antenna oscillates, then adjust control counterclockwise until antenna stops oscillating. The control should be set as far clockwise as possible without causing oscillation.
4. On local control monitor, place SCAN MODE switch to SIM position.
5. Open transmitter control panel to expose remote switching control.
6. Direct second person at control-indicator site to place POWER switch on master control-indicator to ON position.
7. On remote switching control, adjust R59 SEARCH RPM control so that blanked sectors, located on ppi display of master control-indicator, rotate counterclockwise in sequence and do not overlap from one rotation to the next. This should occur at a rotational speed of approximately 16 rpm.
8. Close transmitter control panel.
9. On receiver-transmitter main power panel, place SCAN switch to OFF position.
10. On local control monitor, place LOCAUREMOTE switch to IND position.

4-47. PERFORMANCE TESTS.

The following performance tests should be performed by organizational personnel at periodic intervals as prescribed in the organizational PMCS table. These tests are conducted so that any possible equipment degradation can be detected before equipment failure occurs. The tests are divided into eight parts, with each part testing a specific component. If equipment malfunction is detected, reference is made to the appropriate corrective action. Personnel are listed only if a task requires more than one technician.

LOW-VOLTAGE POWER SUPPLY TEST

TEST EQUIPMENT REQUIRED: Multimeter TS-352 B/U or AN/USM-223

TEST CONDITIONS: Radar set turned on, Preliminary Control Settings (para 2-4).

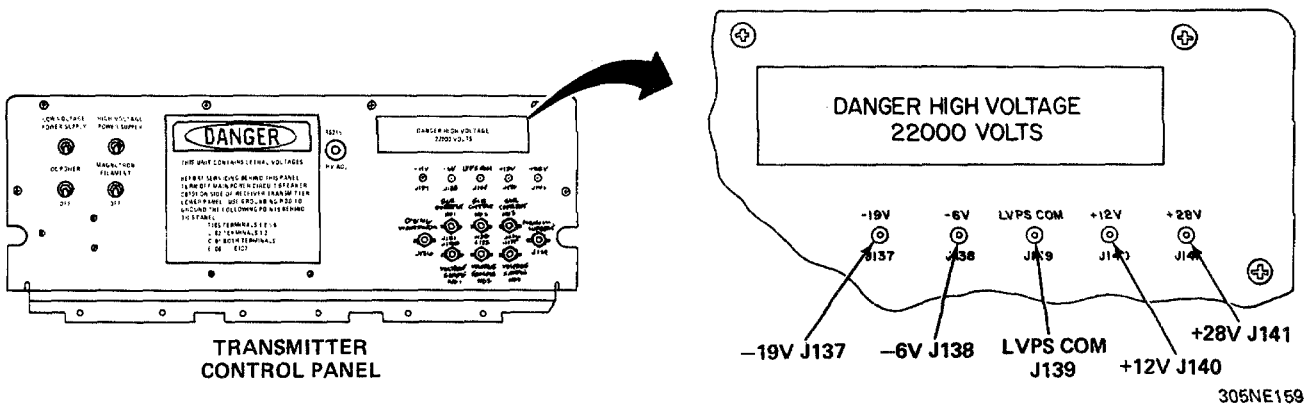

4-47. PERFORMANCE TESTS. (CONT)
LOW VOLTAGE POWER SUPPLY TEST (CONT)

| CONTROL SETTINGS | TEST PROCEDURE | INDICATION |
|--|---|--|
| <p>Set up multimeter to measure + 28 vdc. On receiver transmitter main power panel, place MAIN POWER switch to ON position. On transmitter control panel, place LOW VOLTAGE POWER SUPPLY and MAGNETRON FILAMENT switches to ON position.</p> <p>Disconnect test leads and set up multimeter to measure - 20 vdc.</p> <p>Set up multimeter to measure - 10 vdc.</p> | <p>a. On transmitter control panel, connect positive lead of multimeter to + 28V J141 and connect negative lead to LVPS COM J139.</p> <p>b. Remove positive lead of multimeter from + 28V J141 and connect to + 12V J140.</p> <p>Connect positive lead of multimeter to LVPS COM J139 and connect negative lead to - 19V J137.</p> <p>Remove negative lead of multimeter from -19V J137 and connect to - 6V J138.</p> <p>Disconnect test leads.</p> | <p>a. Multimeter indication of + 28 ± 4 vdc. If indication is incorrect, see paragraph 4-40.</p> <p>b. Multimeter Indication of + 12 + 0.6 vdc. If indication is not correct, see paragraph 4-40.</p> <p>Multimeter indication of - 19 + 1.5 vdc. If incorrect indication is obtained, see paragraph 4-40.</p> <p>Multimeter indication of - 6 + 0.03 vdc. If indication is incorrect, see paragraph 4-40.</p> |

LOCAL CONTROL MONITOR TEST

TEST EQUIPMENT REQUIRED: Multimeter TS-325 B/U or ANIUSM-223
 TEST CONDITIONS: Radar set turned on, Preliminary Control Settings (para 2-4).

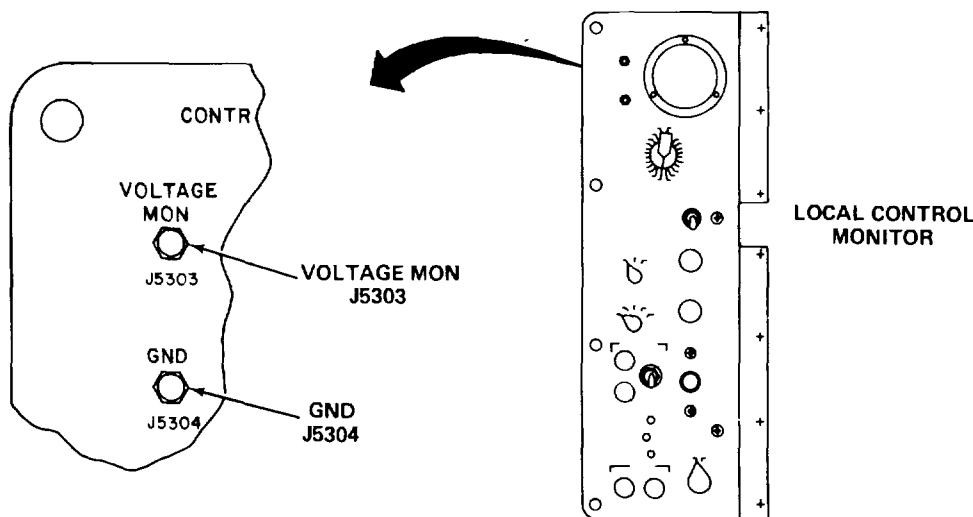

305NE160

4-47. PERFORMANCE TESTS. (CONT)

NOTE

If MONITOR meter and multimeter indications differ consistently, MONITOR meter is misaligned. Refer to higher category of maintenance.

| CONTROL SETTINGS | TEST PROCEDURE | INDICATION |
|---|---|--|
| <p>On local control monitor, place LOCAUREMOTE switch in RT position. Place MONITOR switch to + 35V position. Set up multimeter to measure +35 v. Place MONITOR switch to + 28V position.</p> | <p>On local control monitor, connect positive lead of multimeter to VOLTAGE MON J5303 and connect negative lead to GND J5304.</p> <p>Same as above.</p> | <p>MONITOR meter and multi-meter indicate + 35 + 1 vdc. If indications are Incorrect, see paragraph 4-40.</p> <p>MONITOR meter and multi-meter indicate + 28 + 2 vdc. If indications are incorrect, refer to higher category of maintenance.</p> |
| <p>Place MONITOR switch to + 15V position.</p> | <p>Same as above.</p> | <p>MONITOR meter and multi-meter indicate + 15 + 1 vdc. If indications are incorrect, refer to higher category of maintenance.</p> |
| <p>Place MONITOR switch to + 12V position.</p> | <p>Same as above.</p> | <p>MONITOR meter and multi-meter indicate + 12 + 1 vdc. If indications are incorrect, see paragraph 4-40.</p> |
| <p>Place MONITOR switch to - 35V position. Set up multimeter to measure - 35 vdc.</p> | <p>Connect positive lead of multimeter to GND J5304 and connect negative lead to VOLTAGE MON J5303.</p> | <p>MONITOR meter and multi-meter indicate - 35 + 1 vdc. If indications are incorrect, see paragraph 4-40.</p> |
| <p>Place MONITOR switch to - 12V position.</p> | <p>Same as above.</p> | <p>Monitor meter and multimeter indicate - 12+ 1 vdc. If indications are incorrect, see paragraph 4-40.</p> |

4-47. PERFORMANCE TESTS. (CONT)

LOCAL CONTROL MONITOR TEST (CONT)

| CONTROL SETTINGS | TEST PROCEDURE | INDICATION |
|---|--|--|
| <p>On local control monitor, place SCAN MODE switch to NORM position. Place MONITOR switch to AZ-EL RLY GATE position. Set up multimeter to measure + 50 vdc.</p> | <p>Connect negative lead of multimeter to GND J5304 and connect positive lead to VOLTAGE MON J5303. Manually position elevation antenna to top of scan (25 degrees). Manually rotate azimuth antenna counterclockwise from - 15 degrees to + 15 degrees, as indicated on azimuth scan protractor, and observe meter indications.</p> | <p>MONITOR meter and multimeter indicate 0 vdc. If indications are not correct, refer to higher category of maintenance.</p> |
| <p>Same as above.</p> | <p>Manually position azimuth antenna to zero degrees as indicated on azimuth scan protractor. Attach clinometer to elevation antenna clinometer mount, Clinometer Installation (para 4-21). Rotate elevation antenna from - 1 to 10 degrees, as indicated on clinometer and meter indications.</p> | <p>MONITOR meter and multimeter indicate + 28 ± 1 vdc. If indications are incorrect, refer to higher category of maintenance.</p> |
| <p>Place MONITOR switch to AZ-EL UNBLK position. Set up multimeter to read + 10 vdc. antenna counterclockwise to</p> | <p>Manually position elevation antenna to the top of scan (25 degrees). Rotate azimuth refer to higher category of + 20 degrees as indicated on azimuth scan protractor.</p> | <p>MONITOR meter and multimeter indicate + 8 vdc. If indications are incorrect, maintenance</p> |
| <p>Place MONITOR switch to - 10 AZ TILT position. Set up multimeter to read - 5 vdc.</p> | <p>Connect negative lead of multimeter to VOLTAGE MON J5303 and connect positive lead to GND J5304. On local control monitor, ensure SCAN switch is in OFF position and place MAIN POWER switch to ON position. Use ANT SERVO control and tilt azimuth antenna to lower limit of - 1 degree.</p> | <p>MONITOR meter and multimeter indicate - 1 ± 0.5 vdc. If indications are incorrect, refer to higher category of maintenance.</p> |

4-47. PERFORMANCE TESTS. (CONT)

| CONTROL SETTINGS | TEST PROCEDURE | INDICATION |
|---|---|--|
| <p>Place MONITOR switch to + 25° AZ TILT position. Set up multimeter to read - 30 vdc.</p> | <p>Use ANT SERVO control and tilt azimuth antenna to its upper limit of + 25 degrees.</p> | <p>MONITOR meter and multi-meter indicate - 28 ± 0.5 vdc. If indications are incorrect, refer to higher category of maintenance.</p> |
| <p>Place MONITOR switch to - 15° EL SERVO position. Set up multimeter to measure - 5 vdc.</p> | <p>Use ANT SERVO control and servo elevation antenna to - 15 degree limit as indicated on elevation servo protractor.</p> | <p>MONITOR meter and multi-meter indicate -1 ±0.5 vdc. If indications are incorrect, refer to higher category of maintenance.</p> |
| <p>Place MONITOR switch to + 15° EL SERVO position. Set up multimeter to measure - 25 vdc.</p> | <p>Use ANT SERVO control and servo elevation antenna to + 15 degree limit as indicated on elevation servo protractor.</p> | <p>MONITOR meter and multi-meter indicate - 22 ± 0.5 vdc. If indications are incorrect, refer to higher category of maintenance.</p> |
| <p>Place SCAN MODE switch on local control monitor to 35° EL position and place MONITOR switch to 110 EL ANGLE DATA position. Set up multimeter to measure - 5 vdc.</p> | <p>Manually position elevation antenna to bottom dead center of its scan.</p> | <p>MONITOR meter and multi-meter indicate - 1.5 ± 0.5 vdc. If indications are incorrect, refer to higher category of maintenance.</p> |
| <p>Place MONITOR switch to + 35° ANGLE DATA position. Set up multimeter to measure - 10 vdc.</p> | <p>Manually position elevation antenna to - 1 degree as indicated on clinometer.</p> | <p>MONITOR meter and multi-meter indicate - 9 ± 0.5 vdc. If indications are incorrect, refer to higher category of maintenance.</p> |
| <p>Set up multimeter to measure 25 vdc.</p> | <p>Manually position elevation antenna to + 35 degrees as indicated on clinometer.</p> | <p>MONITOR meter and multi-meter indicate 23.5 ±0.5 vdc. If indications are incorrect, refer to higher category of maintenance.</p> |
| <p>Place SCAN MODE switch on local control monitor to NORM position and MONITOR switch to 30° AZ ANGLE DATA position. Set up multi-meter to measure - 10 vdc.</p> | <p>Manually rotate azimuth antenna to - 15 degrees as indicated on azimuth scan protractor.</p> | <p>MONITOR meter and multi-meter indicate - 9 vdc. If indications observed are incorrect, refer to higher category of maintenance.</p> |

4-47. PERFORMANCE TESTS. (CONT)

LOCAL CONTROL MONITOR TEST (CONT)

| CONTROL SETTINGS | TEST PROCEDURE | INDICATION |
|--|---|--|
| <p>Place SCAN MODE switch on local control monitor to 600 position and place MONITOR switch to 600 AZ ANGLE DATA position. Set up multimeter to measure - 10 vdc.</p> | <p>Manually position azimuth antenna to - 15 degrees as indicated on azimuth scan protractor.</p> | <p>MONITOR meter and multimeter indicate $- 9 \pm 0.5$ vdc. If indications are incorrect, refer to higher category of maintenance.</p> |
| <p>Set up multimeter to indicate - 30 vdc.</p> | <p>Manually rotate azimuth antenna counterclockwise to + 45 degrees as indicated on azimuth scan protractor.</p> | <p>MONITOR meter and multimeter indicate 27 ± 0.5 vdc. If indications are Incorrect, refer to higher category of maintenance.</p> |
| <p>Place SCAN MODE switch on local control monitor to NORM position and place MONITOR switch to 11° EL ANGLE VOLTS position.</p> | <p>Manually position elevation antenna to - 1 degree as indicated on clinometer.</p> | <p>MONITOR meter and multimeter indicate 0 vdc. If - indications are incorrect, refer to higher category of maintenance.</p> |
| <p>Place SCAN MODE switch on local control monitor to 350 EL SCAN position and MONITOR switch to + 35° EL ANGLE VOLTS position. Set up multimeter to measure +20 vdc. Same as above.</p> | <p>Manually position elevation antenna to - 1 degree as indicated on clinometer.</p> | <p>MONITOR meter and multimeter indicate 0 vdc. If - indications are incorrect, refer to higher category of maintenance.</p> |
| <p>Same as above.</p> | <p>Connect negative lead of multimeter to GND J5304 and connect positive lead to VOLTAGE MON J5303. Manually position elevation antenna to + 35 degrees as indicated on clinometer.</p> | <p>MONITOR meter and multimeter indicate 14.5 ± 0.5 vdc. If indications are - incorrect, refer to higher category of maintenance.</p> |
| <p>Place SCAN MODE switch on local control monitor to NORM position and place MONITOR switch to 300 AZ ANGLE VOLTS position.</p> | <p>Manually rotate azimuth antenna to - 15 degrees as Indicated on azimuth scan protractor.</p> | <p>MONITOR meter and multimeter indicate 0 vdc. If - indications are incorrect, refer to higher category of maintenance.</p> |

4-47. PERFORMANCE TESTS. (CONT)

| CONTROL SETTINGS | TEST PROCEDURE | INDICATION |
|--|---|---|
| Place SCAN MODE switch on local control monitor to 60° position and place MONITOR switch to 60° AZ ANGLE VOLTS position. Set up multimeter to read + 18 vdc. | Manually position azimuth antenna to - 15 degrees as indicated on azimuth scan protractor. | MONITOR meter and multi-meter indicate 0 vdc. If indications are incorrect, refer to higher category of maintenance. |
| Same as above. | Manually rotate azimuth antenna counterclockwise to + 45 degrees as indicated on azimuth scan protractor. | MONITOR meter and multi-meter indicate + 18 ± 0.5 vdc. If indications are incorrect, refer to higher category of maintenance. |

ELECTRONIC FILTERS PERFORMANCE TEST

TEST EQUIPMENT REQUIRED: Multimeter TS-352 B/U or AN/USM-223.
 TEST CONDITIONS: Radar set turned on, Preliminary Control Settings (para 2-4), Clinometer installed on elevation antenna clinometer mount (para 4-21).

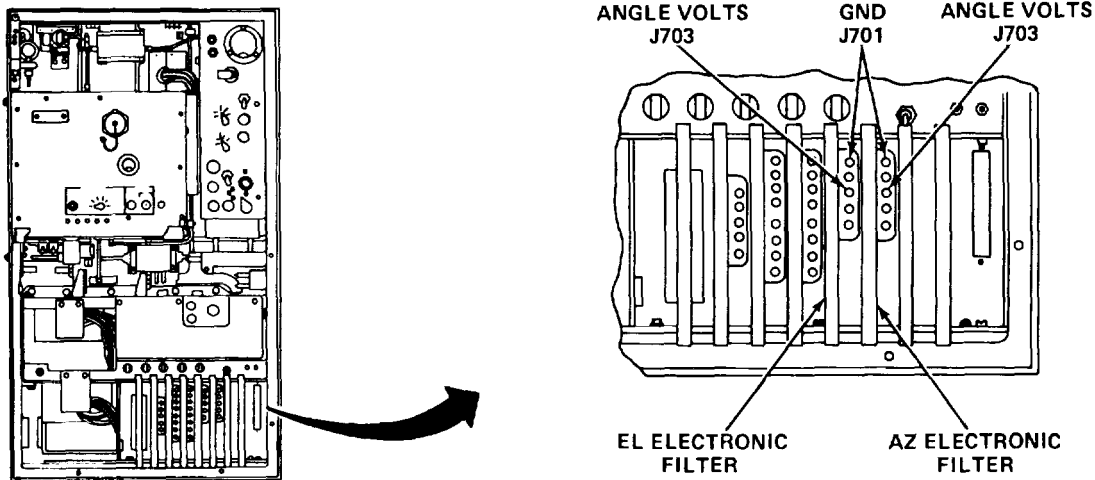

305NE161

| CONTROL SETTINGS | TEST PROCEDURE | INDICATION |
|--|--|---|
| On local control monitor, place LOCAL/REMOTE switch to RT position and place SCAN MODE switch to NORM position. Set up multimeter to measure any positive voltage. | Manually position elevation antenna to - 1 degree as indicated on clinometer. On elevation electronic filter, connect negative lead of multimeter to GND J701 and connect positive lead to ANGLE VOLTS J703. | Multimeter indication of 0 vdc. If indication is incorrect, see paragraph 4-42. |

4-47. PERFORMANCE TESTS. (CONT)

ELECTRONIC FILTERS PERFORMANCE TEST (CONT)

| CONTROL SETTINGS | TEST PROCEDURE | INDICATION |
|------------------|---|---|
| Same as above. | <p>Manually position azimuth antenna to - 15 degrees as indicated on azimuth scan Protractor. On azimuth electronic filter, connect negative lead of multimeter to GND J701 and positive lead to ANGLE VOLTS J703.</p> <p>Disconnect multimeter leads and place LOCAUREMOTE switch to IND position. Close receiver and transmitter doors.</p> | Multimeter indication of 0 vdc. If indication is incorrect, see paragraph 4-40. |

CONTROL-INDICATOR VOLTAGES TEST

TEST CONDITIONS: Radar set turned on, Preliminary Control Settings (para 2-4).

NOTE

Perform the following test procedure on both control-indicators.

| CONTROL SETTINGS | TEST PROCEDURE | INDICATION | | | | | | | | | | | | | | | | |
|--|---|------------|------|---------------|-------|-------|---------------|----------|------|-------|-----------|------------|---------------|-------------|--------|---------------|--|--|
| On control-indicator, place controls to following positions: POWER circuit breaker ON SCAN MODE SEARCH BITE/AZ TILT switch BITE. | <p>Place BITE SELECT switch on control-indicator to following positions and observe AZ TILT/BITE meter</p> <p>Indications:</p> <table border="0"> <tr> <td>- 100V</td> <td>-12V</td> </tr> <tr> <td>- 35V UNRGLTD</td> <td>+ 12V</td> </tr> <tr> <td>- 35V</td> <td>+ 12V UNRGLTD</td> </tr> <tr> <td>- 35VRT*</td> <td>+35V</td> </tr> <tr> <td>- 28V</td> <td>+ 35V RT*</td> </tr> <tr> <td>- 18V VERT</td> <td>+ 35V UNRGLTD</td> </tr> <tr> <td>- 18V HORIZ</td> <td>+ 300V</td> </tr> <tr> <td>- 12V UNRGLTD</td> <td></td> </tr> </table> | - 100V | -12V | - 35V UNRGLTD | + 12V | - 35V | + 12V UNRGLTD | - 35VRT* | +35V | - 28V | + 35V RT* | - 18V VERT | + 35V UNRGLTD | - 18V HORIZ | + 300V | - 12V UNRGLTD | | AZ TILT/BITE meter needle indicates in green zone on meter for each BITE SELECT switch position. If any indication is not correct, see paragraph 4-41. |
| - 100V | -12V | | | | | | | | | | | | | | | | | |
| - 35V UNRGLTD | + 12V | | | | | | | | | | | | | | | | | |
| - 35V | + 12V UNRGLTD | | | | | | | | | | | | | | | | | |
| - 35VRT* | +35V | | | | | | | | | | | | | | | | | |
| - 28V | + 35V RT* | | | | | | | | | | | | | | | | | |
| - 18V VERT | + 35V UNRGLTD | | | | | | | | | | | | | | | | | |
| - 18V HORIZ | + 300V | | | | | | | | | | | | | | | | | |
| - 12V UNRGLTD | | | | | | | | | | | | | | | | | | |

*Although monitored at the control-indicator, these voltages are from the receiver-transmitter.

4-47. PERFORMANCE TESTS. (CONT)

| CONTROL SETTINGS | TEST PROCEDURE | INDICATION |
|--|--|--|
| If necessary, adjust PPI CENTERING VERT and HORIZ controls to position sweep on center of grid line overlay. | Place BITE SELECT switch to following positions and observe AZ TILT/BITE meter: VERT CNTR VERT BAL VERT CUR HORIZ CNTR HORIZ CUR Place POWER circuit breaker on control-indicator to OFF position. | AZ TILT/BITE meter needle indicates in green zone on meter for each BITE SELECT switch position. If any indication is incorrect, see paragraph 4-43. |

ELEVATION SERVO AND AZIMUTH SCAN PROTRACTOR CHECK

PERSONNEL REQUIRED: Two

TEST CONDITIONS: Radar set turned on, Preliminary Control Settings (para 2-4).

1. On local control monitor, place LOCAUREMOTE switch to RT position and SCAN MODE switch to SRCH position.
2. On local control monitor, place ANT SERVO control to R position and servo elevation antenna to its limit. Verify that antenna clears elevation antenna yoke assembly by 1/4 inch.
3. Verify that elevation servo protractor indicates + 15 degrees. If + 15 degree indication is not observed, elevation scan protractor is misaligned, refer to higher category of maintenance.
4. Install siting scope on elevation support tube siting scope mount (para 4-20).
5. Direct second person to position a stadia rod or straight pole approximately 1 mile from radar until it is alined with vertical crosshair in siting scope. Maintain stadia rod in this position.
6. Remove siting scope from elevation support tube siting scope mount and install on elevation antenna siting scope mount.
7. Servo elevation antenna using ANT SERVO control on local control monitor to position antenna until vertical crosshair on siting scope is alined with stadia rod.
8. Observe that elevation servo protractor indicates 0 degrees. If 0-degree indication is not obtained, elevation scan protractor is misaligned; refer to higher category of maintenance.
9. Remove siting scope from elevation antenna siting scope mount and install on azimuth antenna siting scope mount (para 4-20).
10. Manually rotate azimuth antenna until vertical crosshair on siting scope is alined with stadia rod.
11. Verify that azimuth scan protractor indicates 0 degrees. If 0-degree indication is not observed, azimuth scan protractor is misaligned, refer to higher category of maintenance.
12. Remove siting scope from azimuth antenna and store in transmitter door.

4-47. PERFORMANCE TESTS. (CONT)**PRECISION SCAN MODE CHECK**

TEST CONDITIONS: Radar set turned on, Preliminary Control Settings (para 2-4).

1. On local control monitor, place LOCAUREMOTE switch to RT position and SCAN MODE switch to 350position.

WARNING

Be extremely careful when performing steps 2 through 6 to avoid being struck by scanning antennas.

2. Place SCAN switch on local control monitor to ON position.
3. Observe that scan sequence is as follows: azimuth antenna counterclockwise, elevation antenna up; azimuth antenna clockwise, elevation antenna down. If scan sequence is not as indicated, 35° elevation synchro B5303 is incorrectly nulled; refer to higher category of maintenance.
4. Verify that azimuth antenna scans sector of approximately 30 degrees, centered around 0-degree mark on azimuth scan protractor, and is not displaced 180 degrees. If scan sector is displaced 180 degrees, azimuth synchro B1001 is incorrectly nulled, refer to higher category of maintenance.
5. On local control monitor, place SCAN MODE switch to 60° position and observe that antenna scan sequence is as indicated in step 3. If scan sequence is not as indicated, elevation synchro B503 is incorrectly nulled, refer to higher category of maintenance.
6. Observe azimuth scan protractor and ensure azimuth antenna scans an equal distance to each side of + 15 degree indication. If scan is not as indicated, azimuth synchro B1001 requires adjustment, refer to higher category of maintenance.

ELEVATION DRIVE MOTOR CHECK

TEST EQUIPMENT: Stopwatch or wristwatch capable of measuring seconds

TEST CONDITIONS: Radar set turned on, Preliminary Control Settings (para 2-4).

1. On local control monitor, place LOCAUREMOTE switch to RT position and SCAN MODE switch to NORM position.

WARNING

Be extremely careful when performing steps 2 through 4 to avoid being struck by scanning antennas.

2. Place SCAN switch on local control monitor to ON position and observe that azimuth antenna is scanning and elevation antenna is still.

NOTE

In the following steps, rotation is viewed from elevation antenna side of receiver-transmitter.

If any indications observed in step 3 are not as listed, refer to a higher category of maintenance.

4-47. PERFORMANCE TESTS. (CONT)

- On local control monitor, place SCAN MODE switch to each of the positions listed in turn and verify that elevation drive crank rotates clockwise at approximately the speed indicated for each switch position:

| SCAN MODE (switch position) | ROTATIONAL SPEED (rpm) |
|-----------------------------|------------------------|
| SRCH | 30 |
| 35° | 30 |
| 60° | 15 |
| SIM | 30 |

- On local control monitor, place SCAN switch to OFF position and LOCAL/REMOTE switch to IND position.

TRANSMITTER HIGH VOLTAGE TEST

TEST CONDITIONS: Radar set turned on, Preliminary Control Settings (para 2-4).

- On local control monitor, place SCAN MODE switch to SRCH position and LOCAL/REMOTE switch to LOCAL position.
- On transmitter control panel, press segments on indicator switches listed. Lamp inside segment pressed will light:

| INDICATOR SWITCH | SEGMENT PRESSED |
|---|-----------------|
| CONTROL LOCAL-REMOTE switch | LOCAL |
| PULSE SELECT WIDE-NAR switch | WIDE |
| TEST ON-OFF switch | OFF |
| TRIGGER SELECT INTERNAL - EXTERNAL switch | INTERNAL |

- On receiver-transmitter main power panel, place SCAN switch to OFF position.
- On transmitter control panel, press OVLD RESET switch and HV ON-HV READY switch. HV READY segment will light.

NOTE

If any fault indicators light, press OVLD RESET and HV ON switches.

- Place POWER SUPPLY (KILOVOLTS) - FILAMENT (VOLTS) switch on transmitter control panel to POWER SUPPLY (KILOVOLTS) position.

4-47. PERFORMANCE TESTS. (CONT)

TRANSMITTER HIGH VOLTAGE TEST (CONT)

6. On transmitter control panel, observe that meter values are as listed. If any incorrect indication is observed, refer to higher category of maintenance.

| METER | INDICATION |
|----------------------------|---------------|
| POWER SUPPLY VOLTS meter | 3.4 + 0.4 kv |
| POWER SUPPLY CURRENT meter | 260 + 50 ma |
| MAGNETRON CURRENT meter | 27.5 + 5.5 ma |

7. On transmitter control panel, press HV OFF switch. Press NAR segment of PULSE SELECT WIDE-NAR switch and HV ON segment of HV READY-HV ON switch. Segments pressed will light.
8. Observe that meter values are as listed. If any incorrect indication is observed, refer to higher category of maintenance.

| METER | INDICATION |
|----------------------------|--------------|
| POWER SUPPLY VOLTS meter | 3.4 + 0.4 kv |
| POWER SUPPLY CURRENT meter | 100 + 10 ma |
| MAGNETRON CURRENT meter | 9.5 + 1 ma |

9. On transmitter control panel, press HV OFF indicator switch and press REMOTE section of CONTROL LOCAL REMOTE switch.
10. Place LOCAL/REMOTE switch on local control monitor to IND position.
11. Close receiver and transmitter doors.

4-48. LUBRICATION.

Refer to LO 11-5840-281-12-1 for lubrication instructions for radar set.

4-49. TOUCHUP PAINTING.

To protect painted surfaces that have been damaged or otherwise indicate deterioration, prepare surfaces and paint as described below. Refer to TB 43-0118 and TM 43-0139 for detailed instructions on painting and preserving electronic equipment. Refer to SB 11-573 for painting and preservation supplies available for field use. Refer to AR-746-5 for color and marking of Army material.

CAUTION

Special nonconductive paint must be used on laminated reflective surfaces of elevation antenna and azimuth antennas. Avoid excessive thickness of finish (refer to TB 43-0118 and TB SIG 356 for maintenance instructions). Prevent contact of paint or cleaning solvent with any plastic surfaces.

1. Clean surface of area concerned of dust, dirt, loose or flaking paint, and grease (para 3-3).
2. Remove all dead paint, corrosion, and rust with fine sandpaper.
3. Brush on two thin coats of paint, letting first coat dry before applying second coat.

Section VI PREPARATION FOR STORAGE AND SHIPMENT

| Subject | Para | Page |
|-----------------------------|------|-------|
| General..... | 4-50 | 4-155 |
| Disassembly..... | 4-51 | 4-155 |
| Administrative Storage..... | 4-52 | 4-169 |
| Intermediate Storage..... | 4-53 | 4-174 |

4-50. GENERAL.

This section gives procedures for disassembly and repacking of radar set. Before disassembly and repacking, the next scheduled PMCS should be performed, all known problems corrected, and all current MWOs applied.

4-51. DISASSEMBLY.

The disassembly and repacking procedures given are to be used when radar set is not part of a landing control central system. Refer to TM 11-5845-468-12 when radar set is part of Landing Control Central ANITSQ-71B.

Disassembly of radar set requires two personnel and a lifting device with suitable weight capacity.

Electronic Equipment Tool Kit TK-101/G is used for all disassembly procedures unless otherwise indicated.

CAUTION

A dust cover is provided for each cable connector and corresponding receptacle. After disconnecting cables, install dust covers on connectors and receptacles to prevent leakage of moisture into receptacles and cables.

INTERCONNECTING CABLE DISCONNECTION

1. Disconnect cable W3003 connected between receiver-transmitter and ac power distribution box and reel onto cable reel no. 10.
2. Disconnect cable W3004 connected between master control-indicator and ac power distribution box and reel onto cable reel no. 11.
3. Disconnect the following cables and reel onto cable reel no. 7:
 - Cable W3501 connected between receiver-transmitter and azimuth antenna drive
 - Cable W3502 connected between receiver-transmitter and azimuth antenna drive
 - Cable W3503 connected between receiver-transmitter and elevation antenna drive
 - Cables W9503, W9504, W9507, and W9501 connected between master control-indicator and slave control-indicator
 - Ground cable W3006 connected between receiver-transmitter and ground rod.
4. Disconnect cable W3001 connected between receiver-transmitter and master control-indicator and reel onto cable reel no. 8.
5. Disconnect cable W3002 connected between receiver-transmitter and master control-indicator and reel onto cable reel no. 9.
6. Disconnect cable W3005 connected between receiver-transmitter and master control-indicator and reel onto cable reel no. 12.
7. Disconnect cable W3007 connected between primary power source and ac power distribution box and reel onto cable reel no. 12.

4-51. DISASSEMBLY. (CONT)

INTERCONNECTING CABLE DISCONNECTION (CONT)

8. Using rope or heavy twine, secure loose end of cables to cable reels to prevent cables from unraveling.
9. Batten cable reels.

CONTROL-INDICATOR DISASSEMBLY

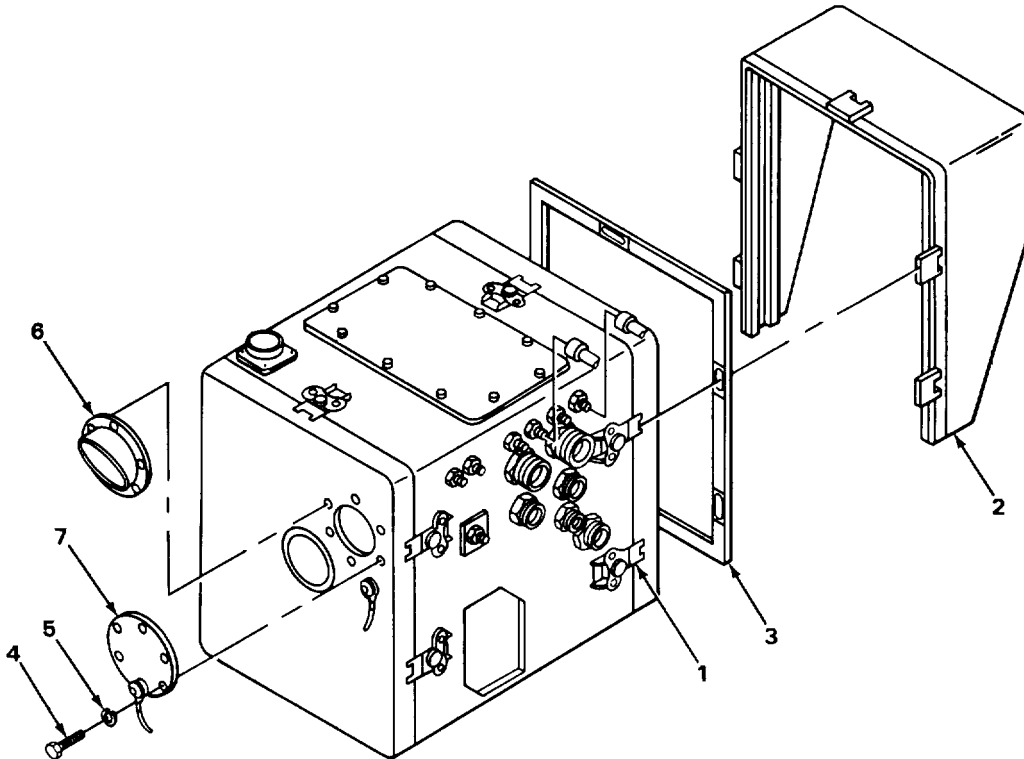

305NE188

NOTE

Perform the following disassembly procedures for both control-indicators.

1. Unlatch five link locks (1) on front of control-indicator and remove indicator rain shield (2).
2. Install front cover (3) on control-indicator and secure with five link locks (1).
3. Remove six screws (4) and lockwashers (5) securing indicator rain deflector (6) and remove Indicator rain deflector.
4. Install cover plate (7) over rear exhaust vent and secure with six screws (4) and
5. Locate indicator rain shield (2) and indicator rain deflector (6) near shipping drum no. 6.

RADAR SET GROUP DISASSEMBLY

Shipping drums no. 5 and no. 6 are packed during radar set group disassembly. Shipping frames no. 1 and no. 2 are packed after radar set group has been completely disassembled and shipping drums have been packed.

4-51. DISASSEMBLY. (CONT)

CAUTION

When disconnecting waveguides, leave preformed packings in waveguide flanges on radar set. Cover all waveguide flanges with waveguide covers provided to prevent moisture leakage into waveguides, and secure with waveguide couplings.

1. Locate shipping drums no. 5 and no. 6 and shipping frames no. 1 and no. 2 near radar set
2. Spread out 10 pads of shipping drum no. 6 in numerical order on a clean, dry surface.

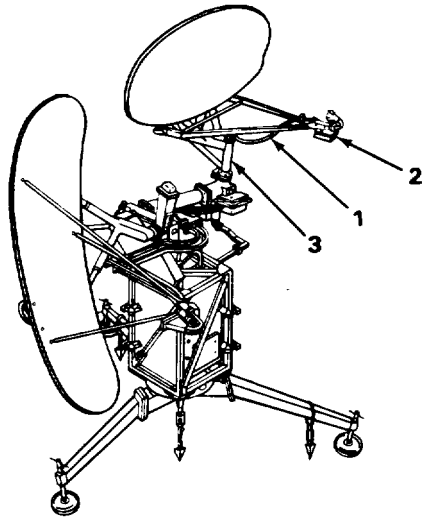

305NE189

3. Disconnect flexible waveguide (1), connected between azimuth horn and polarizer (2), and azimuth antenna yoke assembly (3).
4. Place flexible waveguide in pad 3 of shipping drum no. 6.

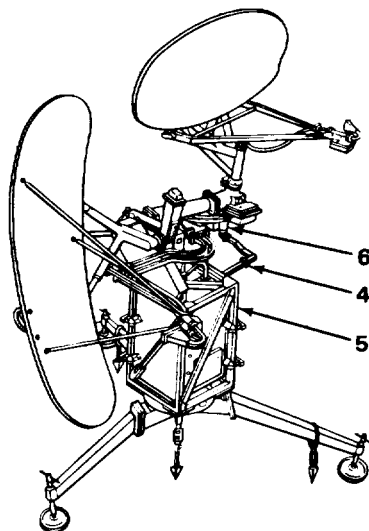

305NE190

5. Disconnect waveguide assembly (4), consisting of flexible waveguide, rigid waveguide, and azimuth directional coupler, connected between receiver-transmitter (5) and azimuth antenna rotary joint (6).

4-51. DISASSEMBLY. (CONT)

RADAR SET GROUP DISASSEMBLY (CONT)

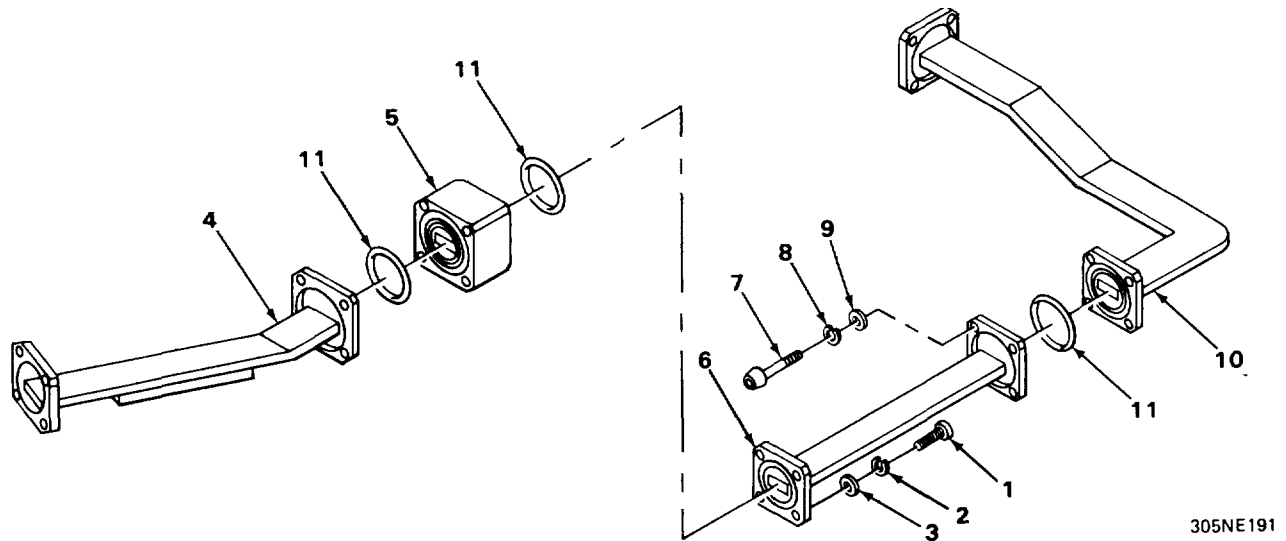

6. Remove four screws (1), lockwashers (2), and flat washers (3) securing azimuth directional coupler (4) and adapter (5) to flexible waveguide (6).
7. Remove four screws (7), lockwashers (8), and flat washers (9) securing rigid waveguide (10) to flexible waveguide (6).
8. Locate azimuth directional coupler (4), adapter (5), flexible waveguide (6), rigid waveguide (10), and preformed packings (11) in pad 7 of shipping drum no. 6.

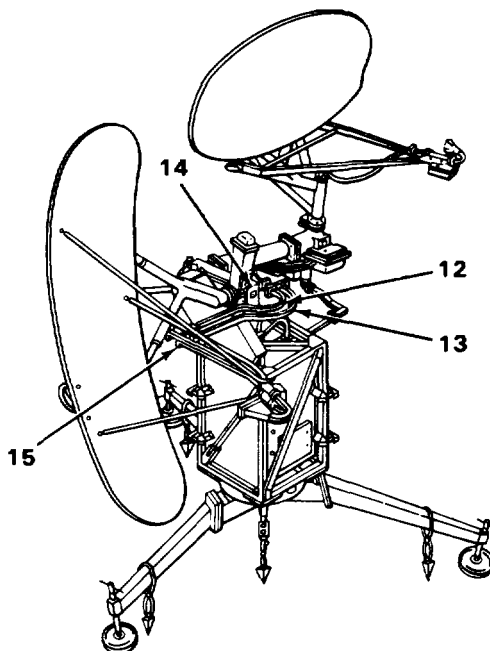

9. Disconnect two flexible waveguides (12 and 13) connected between elevation antenna drive rotary joint (14) and elevation horn and polarizer (15). Locate flexible waveguides in pads 4 and 6 of shipping drum no. 6.

4-51. DISASSEMBLY. (CONT)

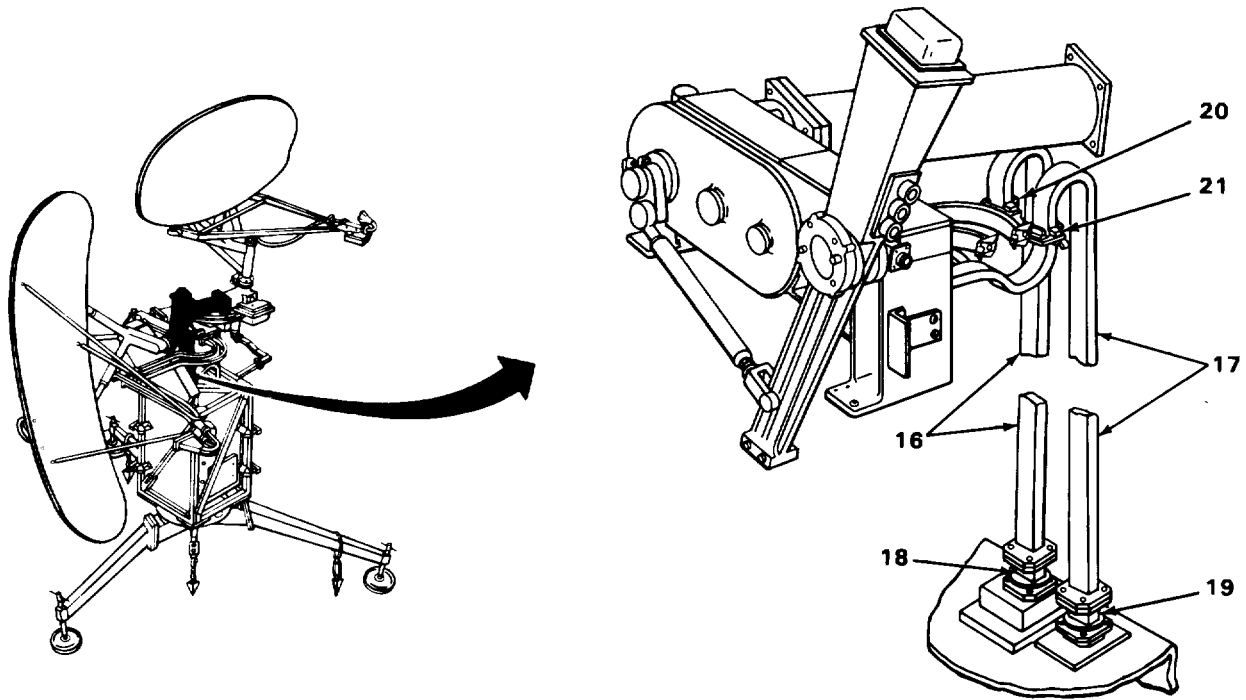

305NE193

10. Disconnect two flexible and rigid waveguide assemblies (16 and 17) connected between elevation attenuator waveguide flanges (18 and 19), on top of receiver-transmitter, and elevation antenna drive flanges (20 and 21), elevation antenna drive.

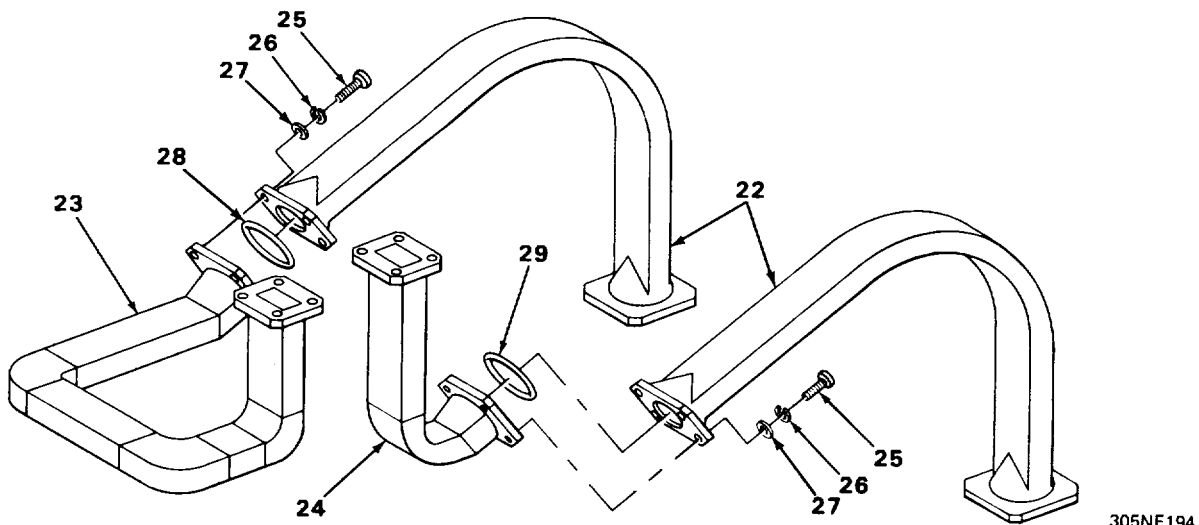

305NE194

11. Disassemble flexible waveguide (22) and rigid waveguide (23 and 24) assemblies by removing eight screws (25), lockwashers (26), and flat washers (27) securing flexible waveguides (22) to rigid waveguides (23 and 24).
12. Locate two flexible waveguides (22) and two rigid waveguides (23 and 24), along with pre-formed packings (28 and 29) in pad 5 of shipping drum no. 6.
13. Disconnect cables W9101 and W9301 from azimuth antenna drive.

4-51. DISASSEMBLY. (CONT)

RADAR SET GROUP DISASSEMBLY (CONT)

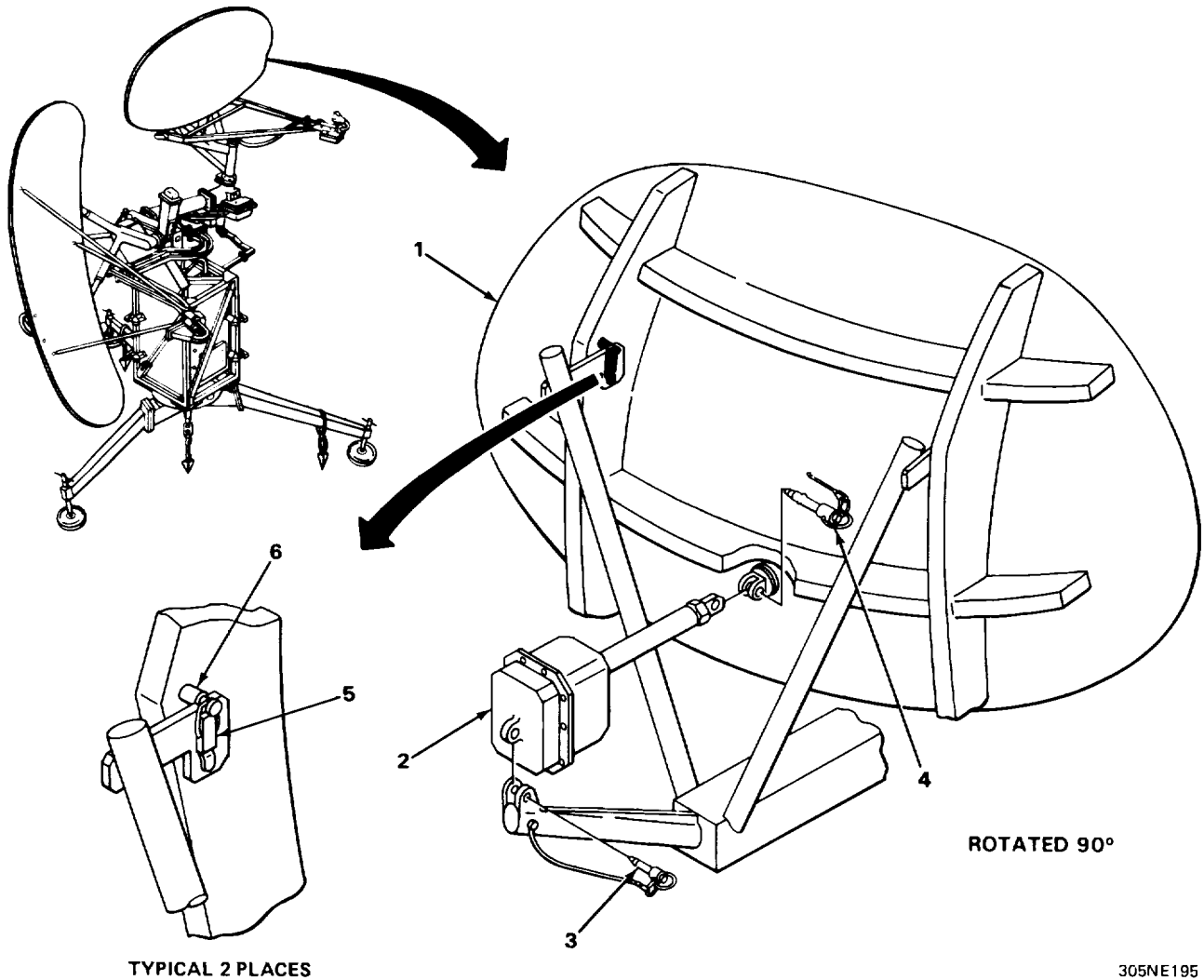

14. While supporting azimuth antenna (1) and servo actuator (2), remove pins (3 and 4) securing servo actuator and remove servo actuator. Place servo actuator in pad 2 of shipping drum no. 6.
15. While supporting azimuth antenna (1), unlatch two antenna latches (5).
16. Using necessary manpower or lifting device with suitable weight capacity, carefully lift azimuth antenna (1) off so that mounting pins (6) clear notches in azimuth antenna yoke assembly and place in proximity of shipping frame no. 1.

4-51. DISASSEMBLY. (CONT)

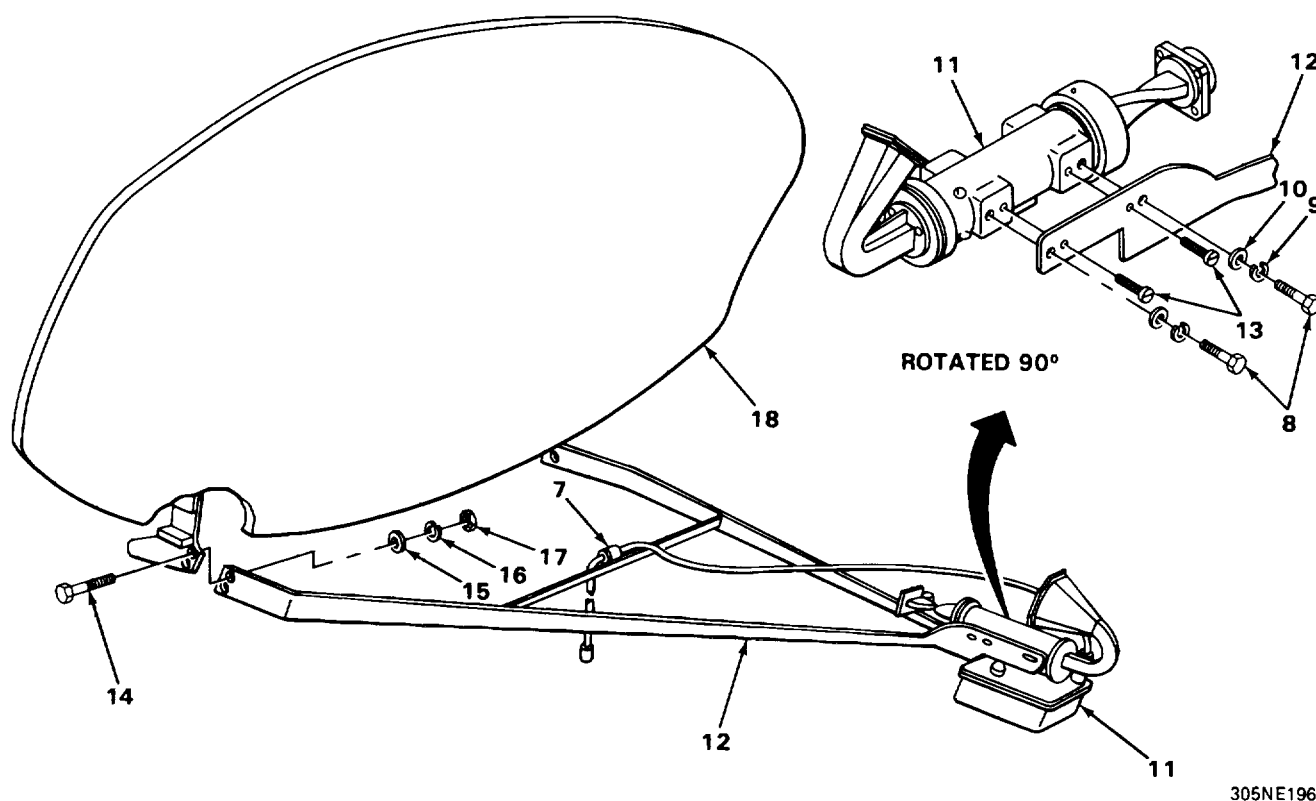

17. Obtain two cloth sacks marked AZIMUTH ANTENNA HARDWARE and AZIMUTH HORN AND POLARIZER HARDWARE from pad 8 of shipping drum no. 6.
18. Loosen cable clamp (7) and remove cable W9301 from clamp.
19. Remove four screws (8), lockwashers (9), and flat washers (10) securing azimuth horn and polarizer (11) to azimuth horn and polarizer support (12).
20. Loosen, but do not remove, four alignment pins (13).
21. Remove azimuth horn and polarizer and place in pad 2 of shipping drum no. 6. Place screws, lockwashers, and flat washers into cloth sack marked AZIMUTH HORN AND POLARIZER HARDWARE.
22. Remove four bolts (14), flat washers (15), lockwashers (16), and nuts (17) securing azimuth antenna horn and polarizer support (12) to azimuth antenna reflector (18). Place bolts, lockwashers, flat washers, and nuts in cloth sack marked AZIMUTH ANTENNA HARDWARE.
23. Disconnect cable W9101 from elevation antenna drive.
24. Disconnect cable W9201 from elevation antenna drive.

4-51. DISASSEMBLY. (CONT)

RADAR SET GROUP DISASSEMBLY (CONT)

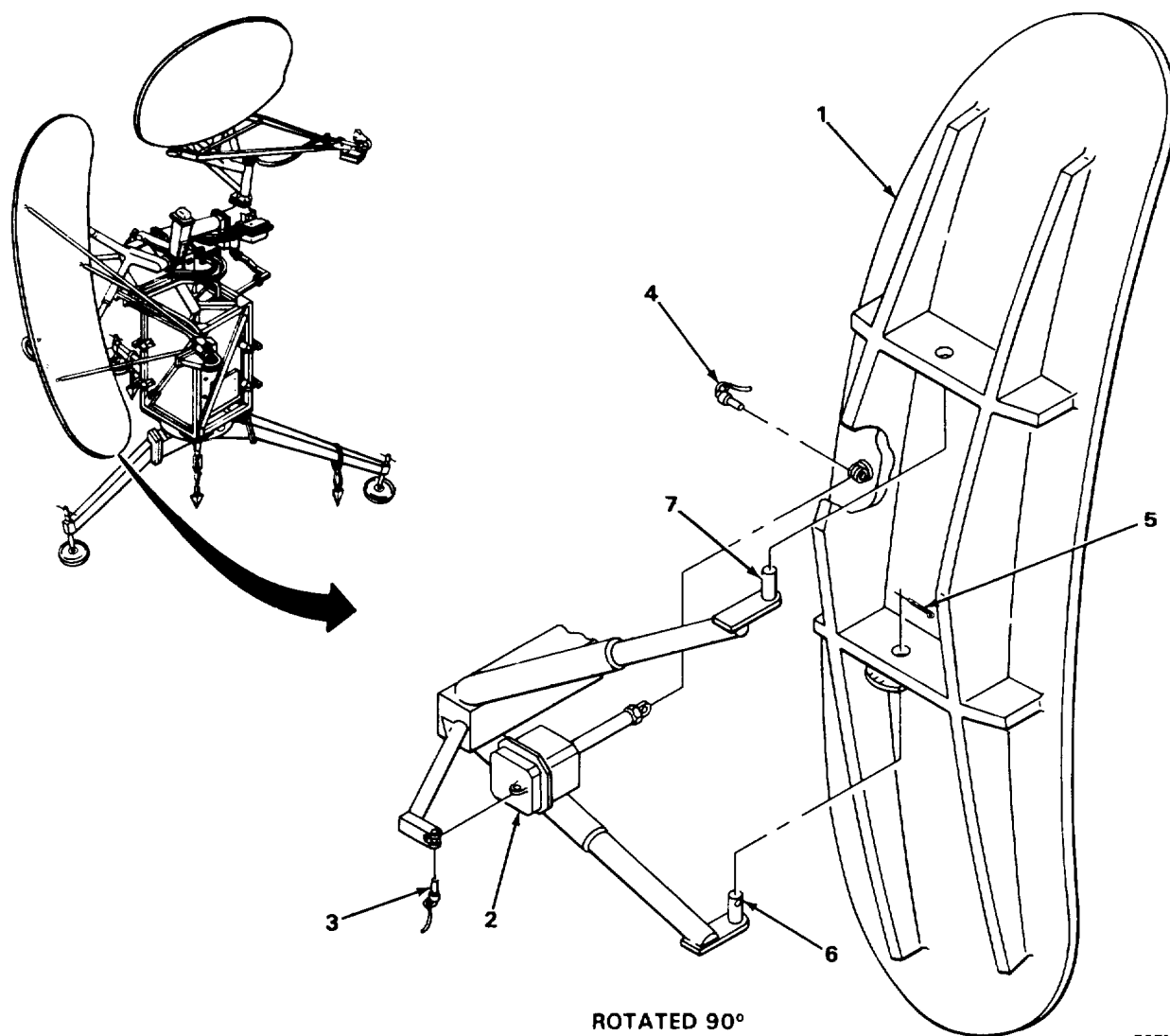

305NE197

25. While supporting elevation antenna (1) and elevation servo actuator (2), remove two pins (3 and 4) that secure servo actuator and remove servo actuator. Place servo actuator in pad 1 of shipping drum no. 6.
26. While supporting elevation antenna (1), remove clip (5) in mounting pin (6).
27. Using necessary manpower or lifting device with suitable weight capacity, carefully lift elevation antenna (1) off mounting pins (6 and 7) and place in proximity of shipping frame no. 2.

4-51. DISASSEMBLY. (CONT)

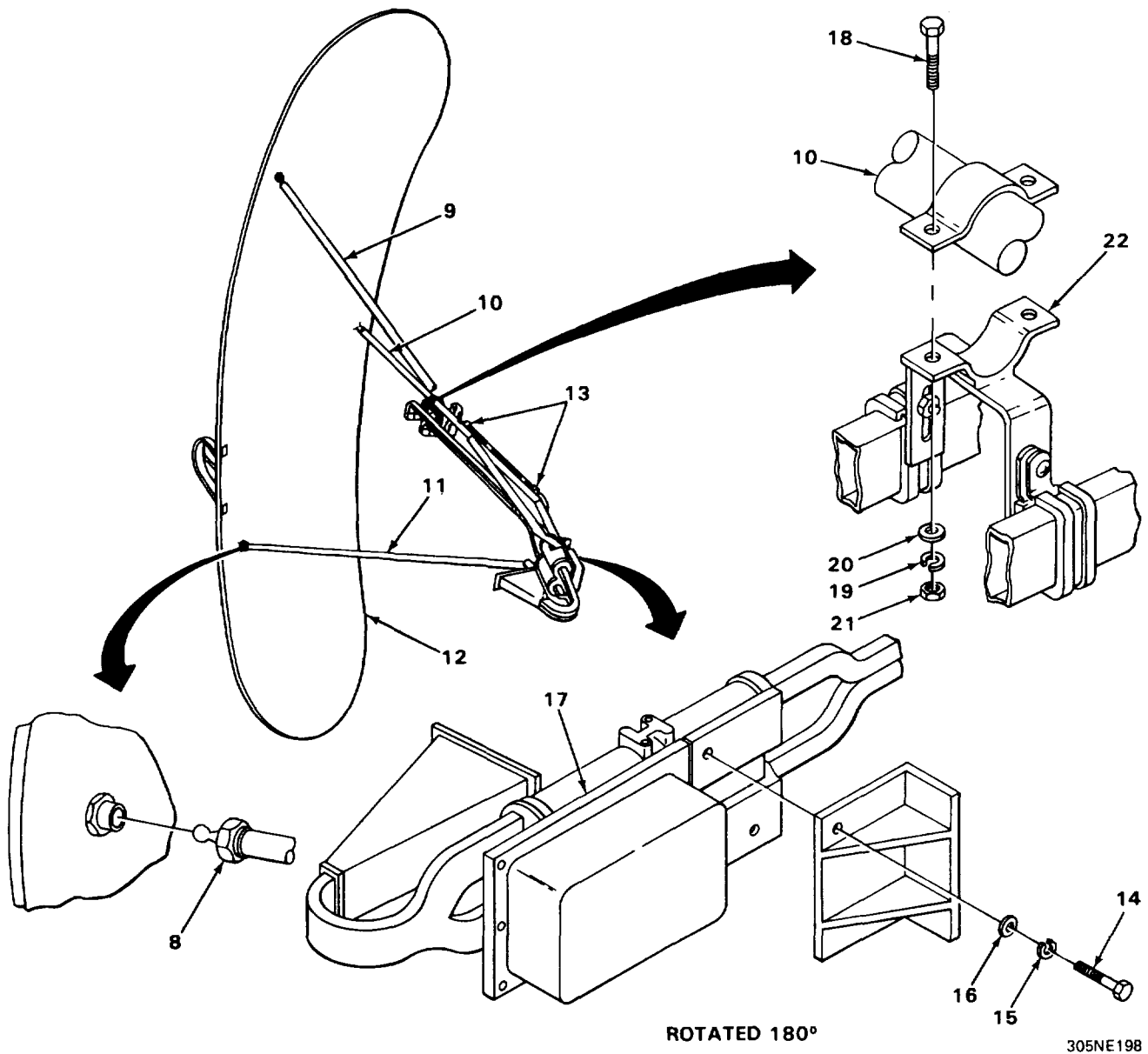

28. Loosen three coupling nuts (8) securing elevation horn and polarizer support arms (9, 10, and 11) to elevation antenna (12).
29. Loosen two clamps (13) securing cable W9201 to center support arm (10) and free cable.
30. Obtain cloth sack labeled ELEVATION HORN AND POLARIZER HARDWARE from pad 8 of shipping
31. Remove six screws (14), lockwashers (15), and flat washers (16) securing elevation horn and polarizer (17) to elevation horn and polarizer support arms (9, 10, and 11).
32. Remove two screws (18), lockwashers (19), flat washers (20), and nuts (21) securing clamp (22) of elevation horn and polarizer (17) to center support arm (10) and remove elevation horn and polarizer. Reassemble clamp with associated hardware.
33. Locate elevation horn and polarizer (17) in proximity of shipping drum no. 5 and place screws (14), lockwashers (15), and flat washers (16) in cloth sack marked ELEVATION HORN AND POLARIZER HARDWARE.

4-51. DISASSEMBLY. (CONT)

RADAR SET GROUP DISASSEMBLY (CONT)

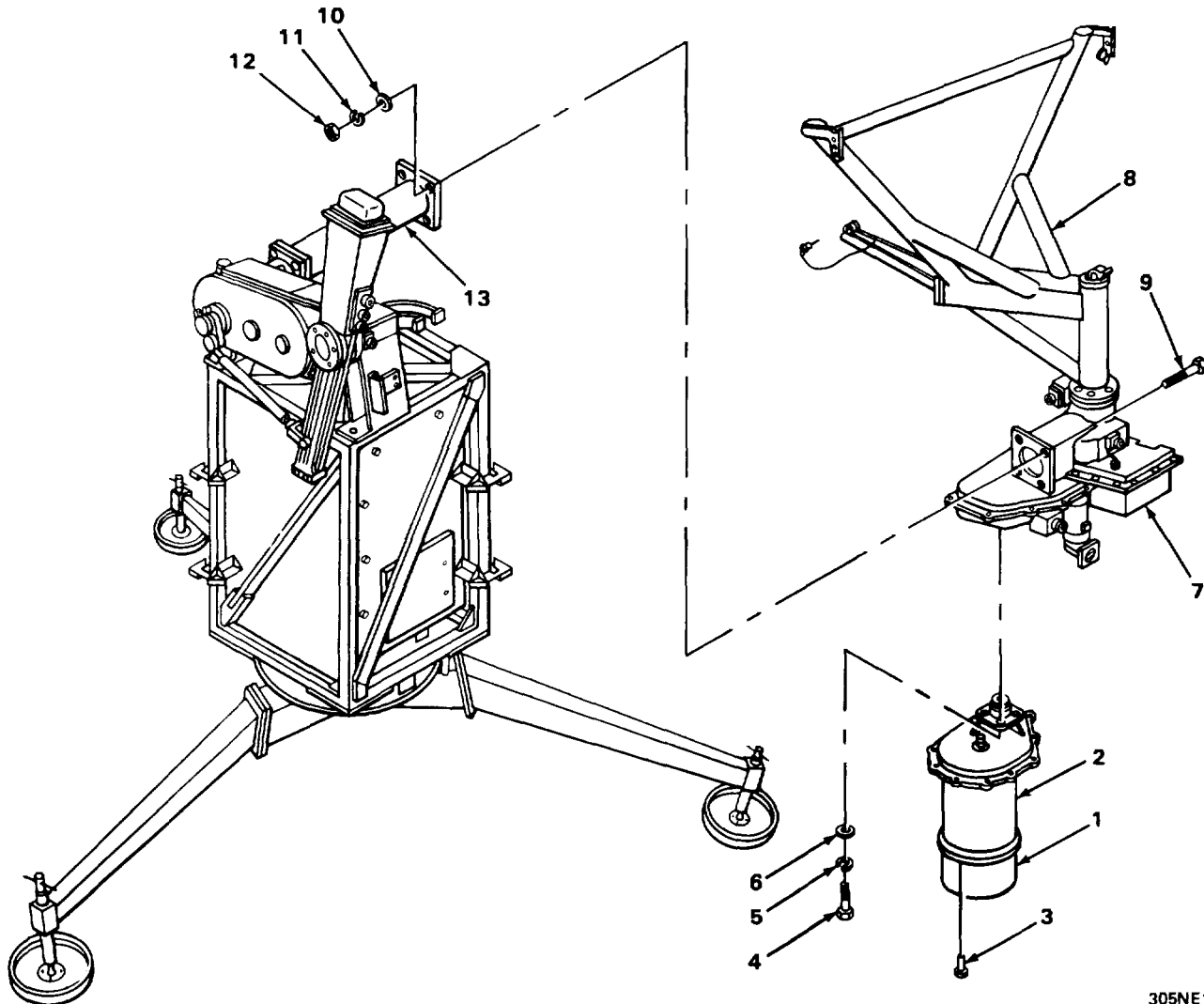

305NE199

34. Install red protective cover (1) over azimuth drive reducer (2) and secure using six
35. Remove four bolts (4), lockwashers (5), and flat washers (6) securing azimuth drive reducer (2) to azimuth antenna drive (7).
36. Obtain cloth sack marked AZIMUTH ANTENNA DRIVE HARDWARE from pad 8 in shipping drum no. 6.
37. Support azimuth antenna drive (7) and azimuth yoke assembly (8) with necessary manpower or lifting device with suitable weight capacity and remove four bolts (9), lockwashers (10), flat washers (11), and nuts (12) securing azimuth antenna drive to elevation antenna drive (13). Carefully lift azimuth antenna drive and azimuth yoke assembly away from elevation antenna drive and place in proximity of shipping frame no. 2.
38. Place four bolts (9), lockwashers (10), flat washers (11), and nuts (12) in cloth sack marked AZIMUTH ANTENNA DRIVE HARDWARE.

4-51. DISASSEMBLY. (CONT)

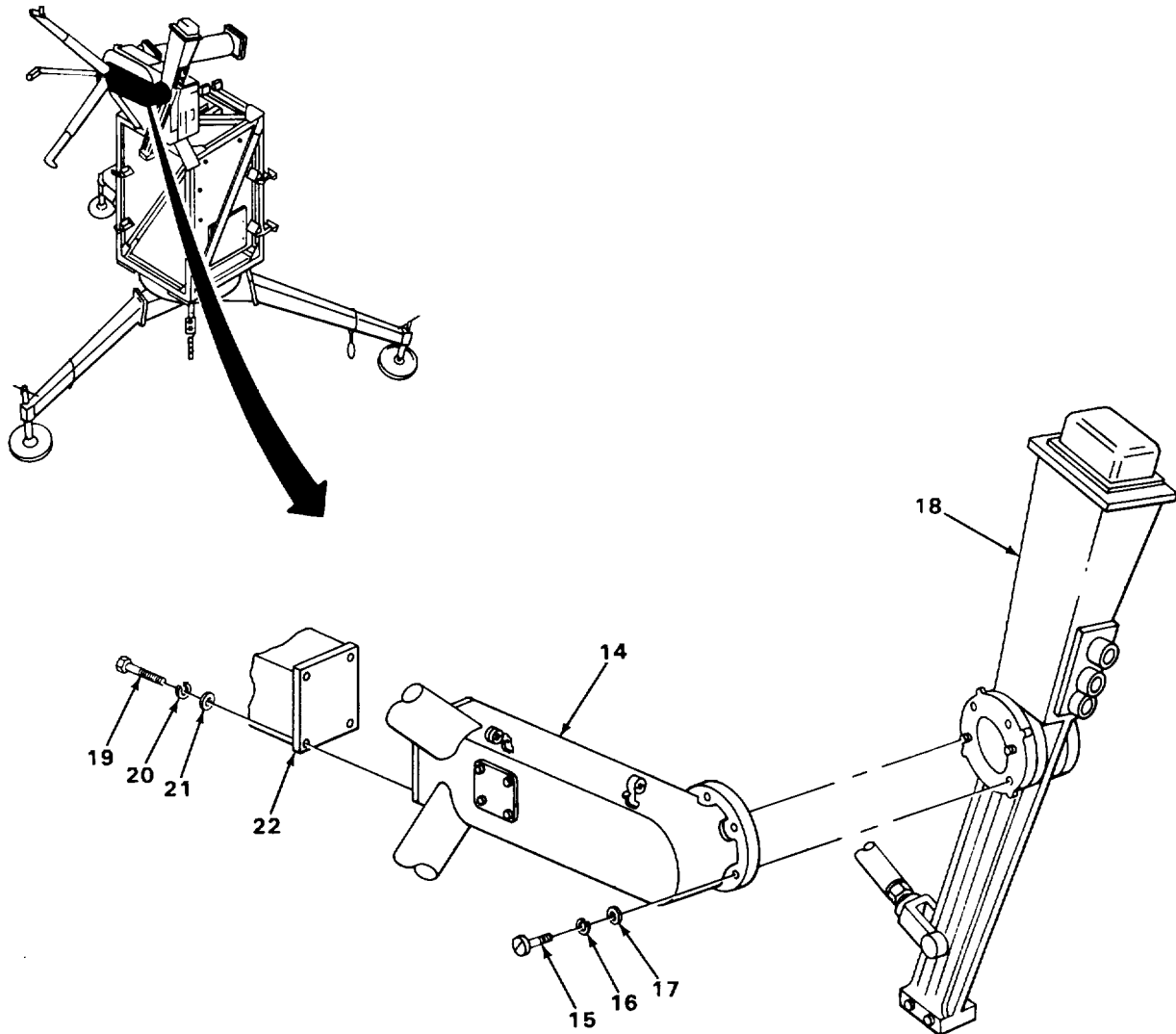

305NE202

39. Obtain cloth sack marked ELEVATION ANTENNA YOKE HARDWARE from pad 8 in shipping drum no. 6.
40. While supporting elevation antenna yoke (14), remove four screws (15), lockwashers (16), and flat washers (17) securing elevation antenna yoke to elevation antenna drive (18). Remove elevation antenna yoke and place in proximity of shipping frame no. 1.
41. Place screws, flat washers, and lockwashers in cloth sack marked ELEVATION ANTENNA YOKE HARDWARE.
42. Remove four screws (19), lockwashers (20), and flat washers (21) securing elevation actuator support arm (22) to elevation antenna yoke (14). Place screws (19), lockwashers (20), and flat washers (21) in cloth sack marked ELEVATION ANTENNA YOKE HARDWARE.

4-51. DISASSEMBLY. (CONT)

RADAR SET GROUP DISASSEMBLY (CONT)

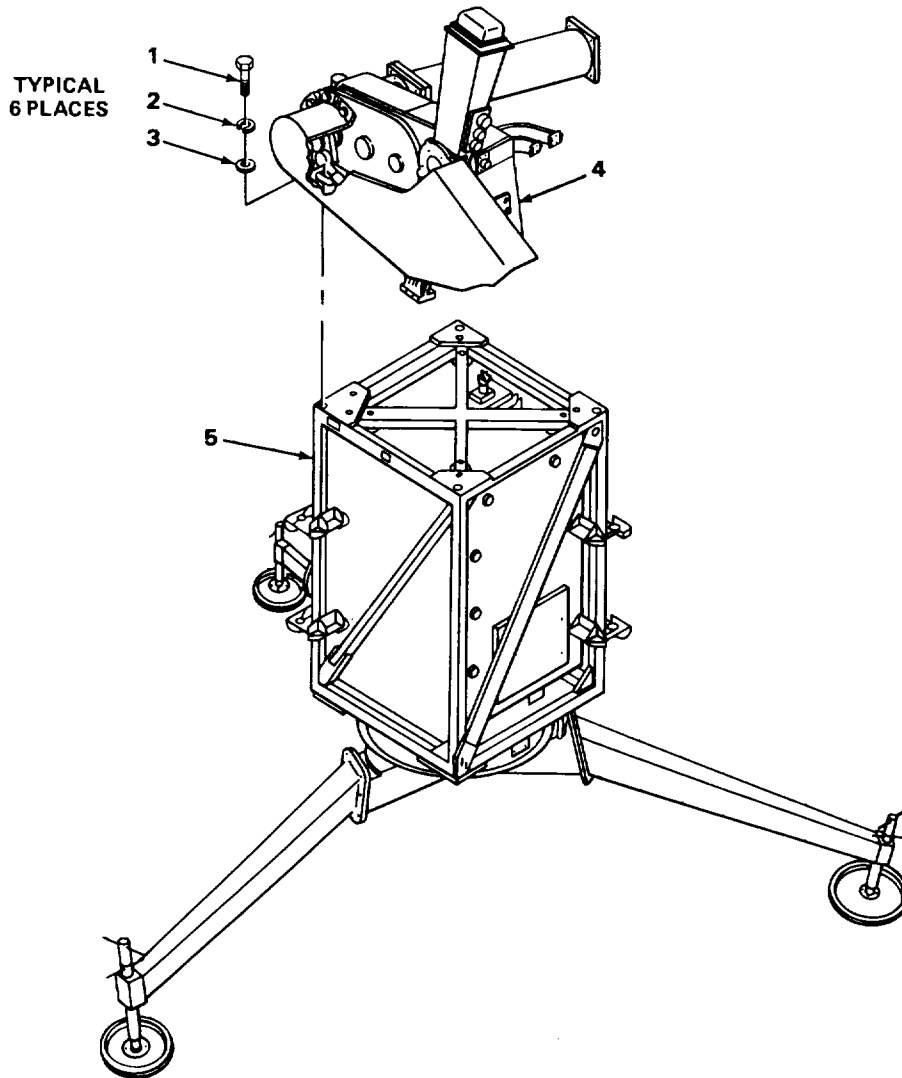

305NE203

43. Obtain cloth sack marked ELEVATION ANTENNA DRIVE HARDWARE in pad 8 of shipping drum no. 6.
44. Remove six screws (1), lockwashers (2), and flat washers (3) securing elevation antenna drive (4) to receiver-transmitter (5) and place hardware in cloth sack marked ELEVATION ANTENNA DRIVE HARDWARE.
45. Using necessary manpower or lifting device with suitable weight capacity, carefully lift elevation antenna drive (4) off receiver-transmitter (5) and place in proximity of shipping frame no. 2.

4-51. DISASSEMBLY. (CONT)

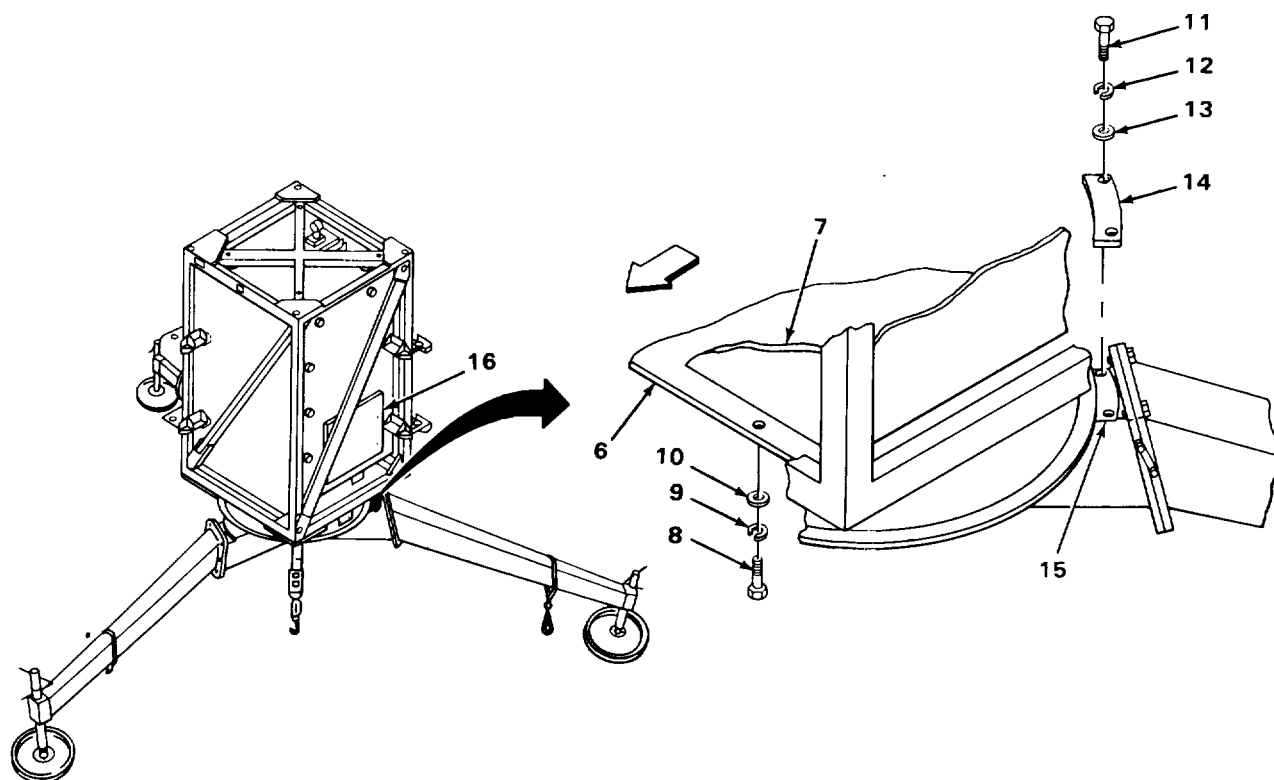

305NE204

46. Obtain cloth sack marked RECEIVER-TRANSMITTER HARDWARE from pad 8 of shipping drum no. 6.
47. Install vent cover (6) on bottom of receiver-transmitter (7) using six fasteners (8), lock-washers (9), and flat washers (10).
48. Remove two screws (11), lockwashers (12), and flat washers (13) attaching each of three strap clamps (14) to antenna pedestal (15). Place hardware in cloth sack marked RECEIVER-TRANSMITTER HARDWARE.
49. Using lifting device with suitable weight capacity, carefully lift receiver-transmitter (7) off antenna pedestal (15).
50. Close exhaust port door (16).
51. Loosen and remove strap ratchet connected to center section antenna pedestal.
52. Remove one 6-inch anchor and three 3-inch anchors from ground.
53. Place strap ratchet in pad 7 and place four anchors in pad 8 of shipping drum no. 6.
54. Obtain cloth sack marked ANTENNA PEDESTAL HARDWARE from pad 8 of shipping drum no. 6.

4-51. DISASSEMBLY. (CONT)

RADAR SET GROUP DISASSEMBLY (CONT)

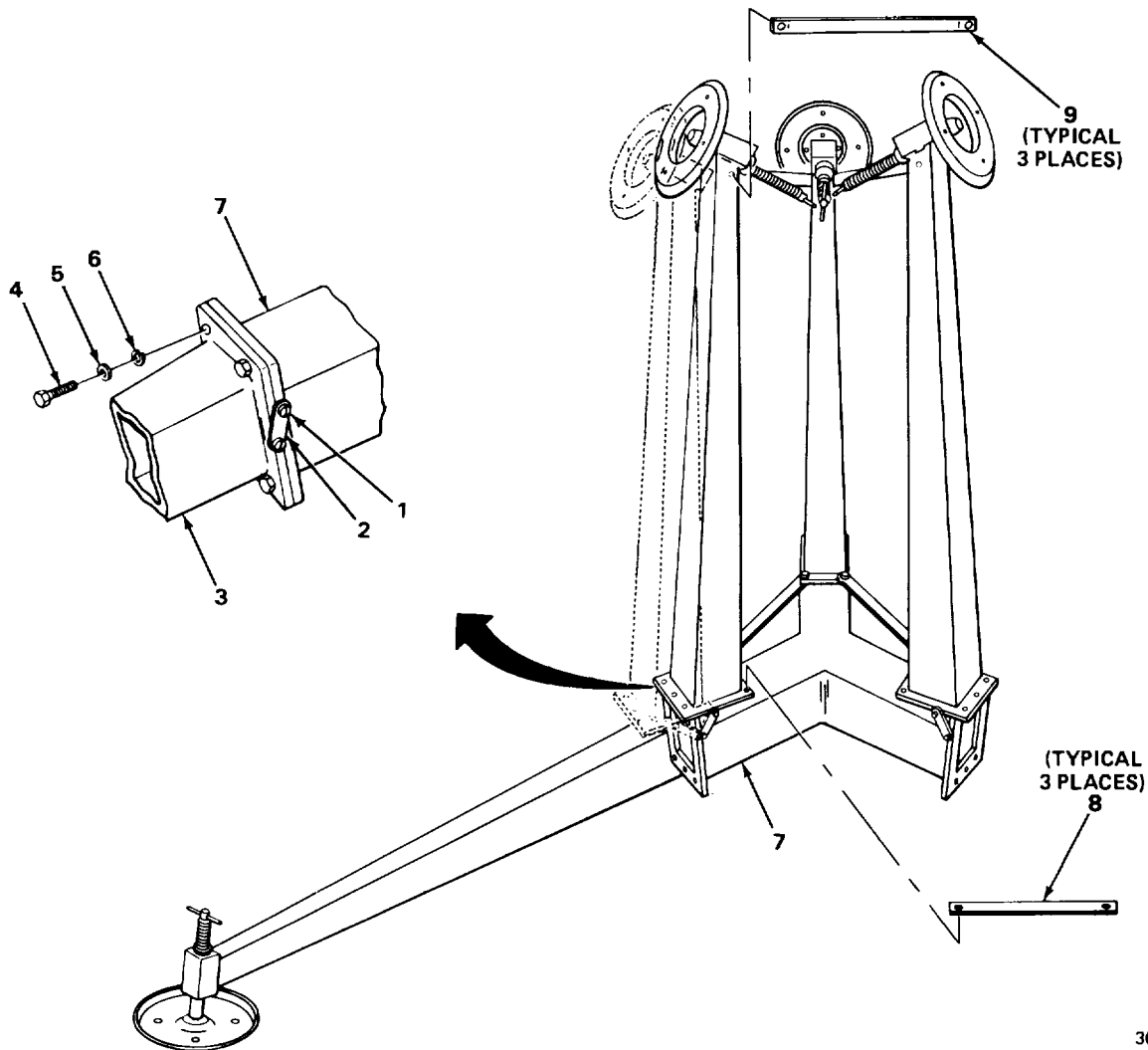

55. Loosen four screws (1) in two retaining hinges (2) in each of three leg assemblies (3).
56. Remove five screws (4), flat washers (5), and lockwashers (6) securing each leg assembly (3) to center section (7) of pedestal and place hardware in cloth sack marked ANTENNA PEDESTAL HARDWARE.
57. Fold each leg assembly (3) upward and secure with three bottom retaining straps (8) and three top retaining straps (9).
58. Tighten four screws (1) in two retaining hinges (2) in each of three leg assemblies (3).

4-52. ADMINISTRATIVE STORAGE.

Administrative storage is accomplished when radar set is to be stored between 1 and 45 days or when it is being shipped over short distances, such as by helicopter airlift.

SHIPPING DRUM NO. 6

1. Place indicator rain deflectors in pad 8 of shipping drum.
2. Place eight cloth sacks containing mounting hardware in pad 8 of shipping drum.

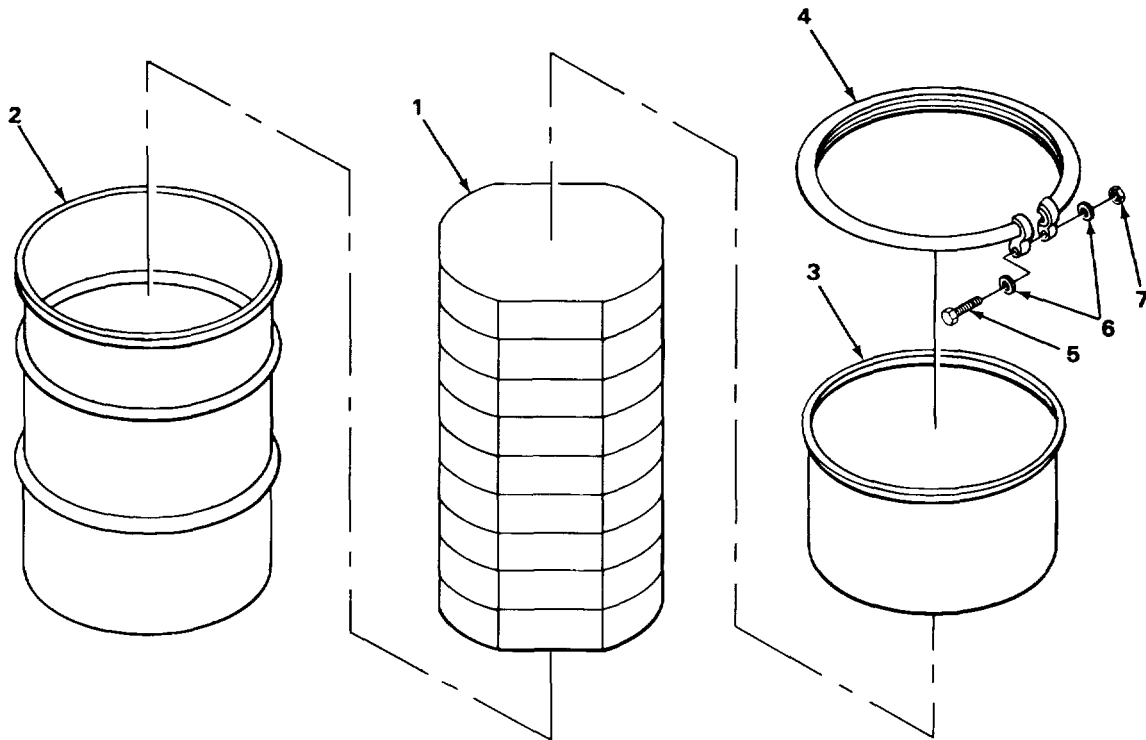

305NE206

3. Starting with pad 1, place pads 1 through 9 (1) into shipping drum (2). Arrange pads so that white line on each pad aligns with white line on inside of shipping drum.
4. Place technical manual, followed by indicator rain shields, in pad 9.

NOTE

If equipment is being packed for intermediate storage (para 4-54), place 9 pounds (4.1 kg) of 16-unit desiccant bags, conforming to MIL-D-3564 class 1 and 2, in shipping drum.

5. Place cover (3) and securing ring (4) on shipping drum (2) and secure using one bolt (5), two washers (6), and nut (7).

4-52. ADMINISTRATIVE STORAGE. (CONT)

SHIPPING FRAME NO. 1

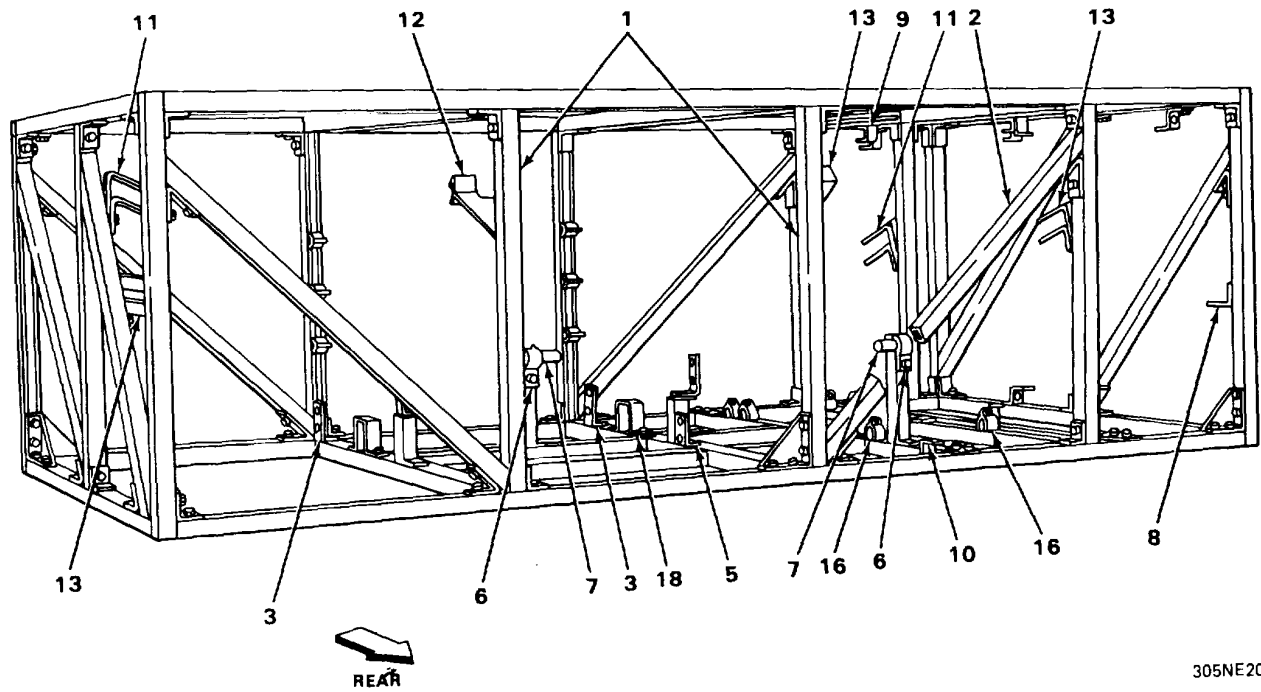
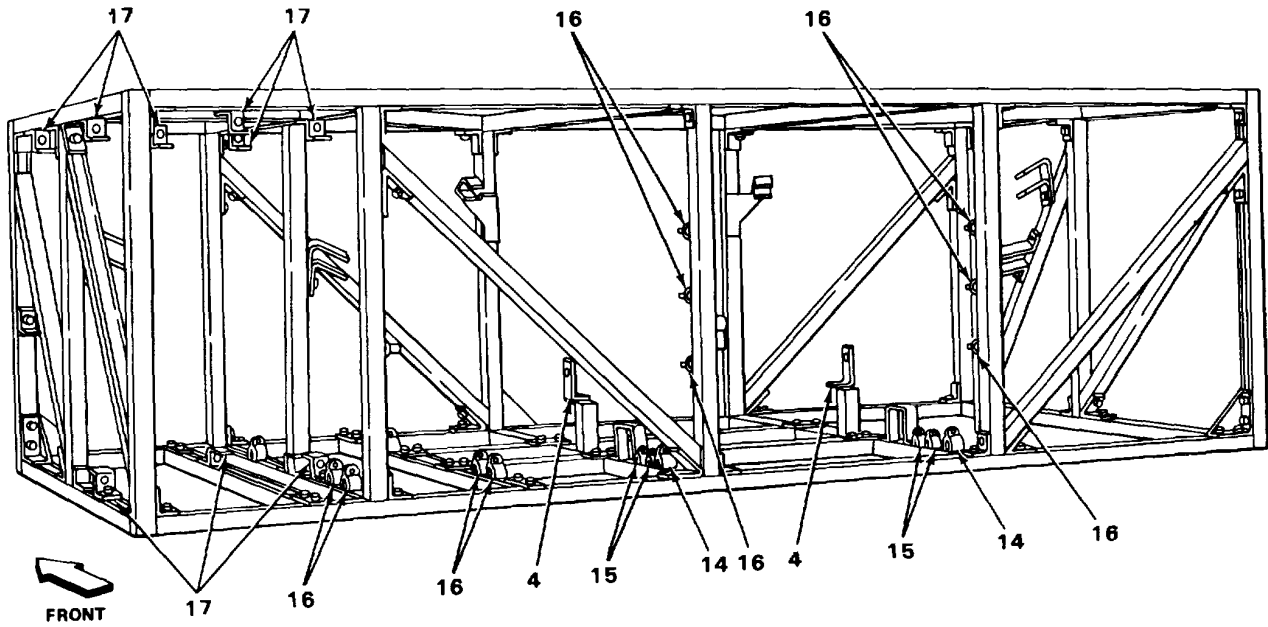

305NE207

4-52. ADMINISTRATIVE STORAGE. (CONT)**CAUTION**

When securing clamps and brackets, avoid overtightening to prevent stripping attaching hardware.

NOTE

Illustrations accompanying unpacking procedures show equipment already installed in shipping frames.

1. Remove hardware securing two trusses (1) and one brace (2) marked REMOVE FOR PACKING AND UNPACKING to rear of shipping frame and remove trusses and brace. Retain hardware for reinstallation.
2. Install azimuth antenna reflector through rear of shipping frame with concave side up and bottom of antenna toward lower front of shipping frame.
3. Attach azimuth antenna reflector to two fittings (3) at bottom front of shipping frame.
4. Temporarily remove two fittings (4) from bottom of shipping frame and install on azimuth antenna mounting pins. Reattach fittings to bottom of shipping frame.
5. Install elevation antenna reflector through rear of shipping frame with concave side up and clinometer and sighting scope mount toward rear of shipping frame.
6. Attach elevation antenna at actuator mount to fitting (5) and secure with locking pin on elevation
7. Loosen two clamps (6) on shipping frame and remove two bushings (7). Install bushings through pivot bores on back of elevation antenna and reattach bushings to shipping frame with
8. Install azimuth horn and polarizer support through opening in rear of shipping frame. Connect narrow end of the V-shaped support to fitting (8) in right rear corner of shipping frame and connect wide ends to plate (9) and fitting (10) using associated hardware.
9. Reinstall two trusses (1) and one brace (2), using associated hardware.
10. Using two brackets (11) and two fittings (12), secure azimuth antenna in shipping frame.
11. Using two fittings (13), secure elevation antenna in shipping frame.
12. Using two clamps (14), clamp ground rod along bottom front of shipping frame.
13. Using four clamps (15), clamp two driving rods along bottom front of shipping frame.
14. Using 12 clamps (16), clamp three reflector supports to bottom of shipping frame.
15. Using nine clamps (17), clamp two polarizer assemblies to bottom of shipping frame and one polarizer assembly to top of shipping frame.

4-52. ADMINISTRATIVE STORAGE. (CONT)

SHIPPING FRAME NO. 2

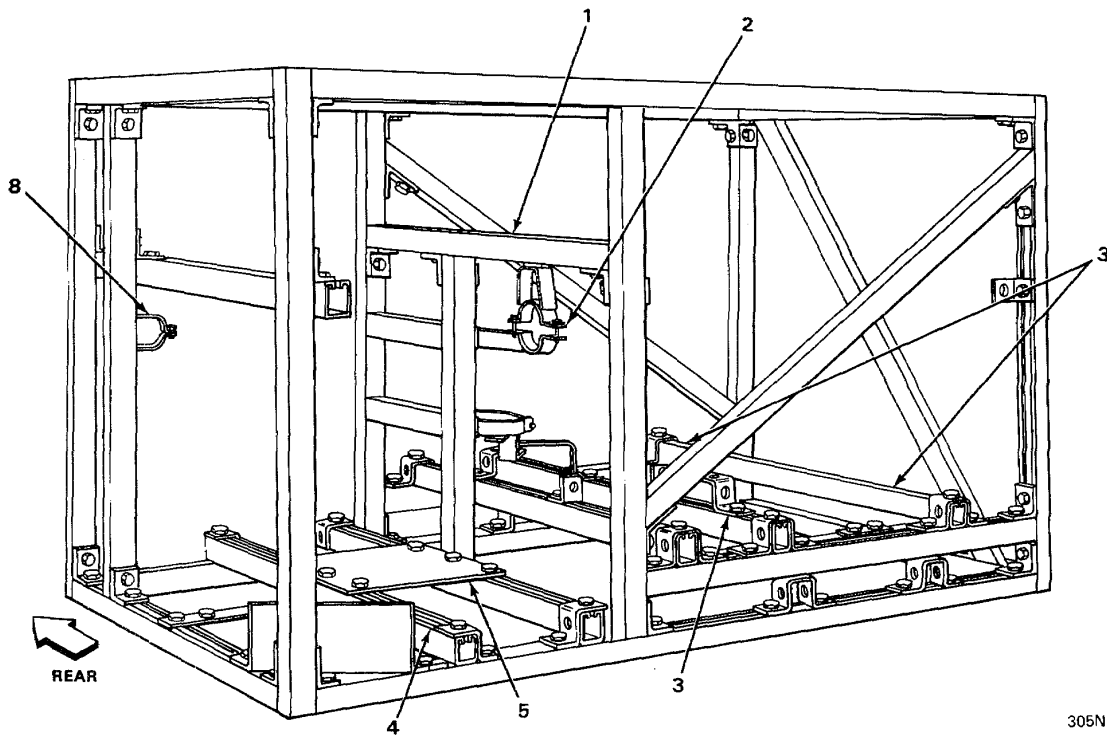
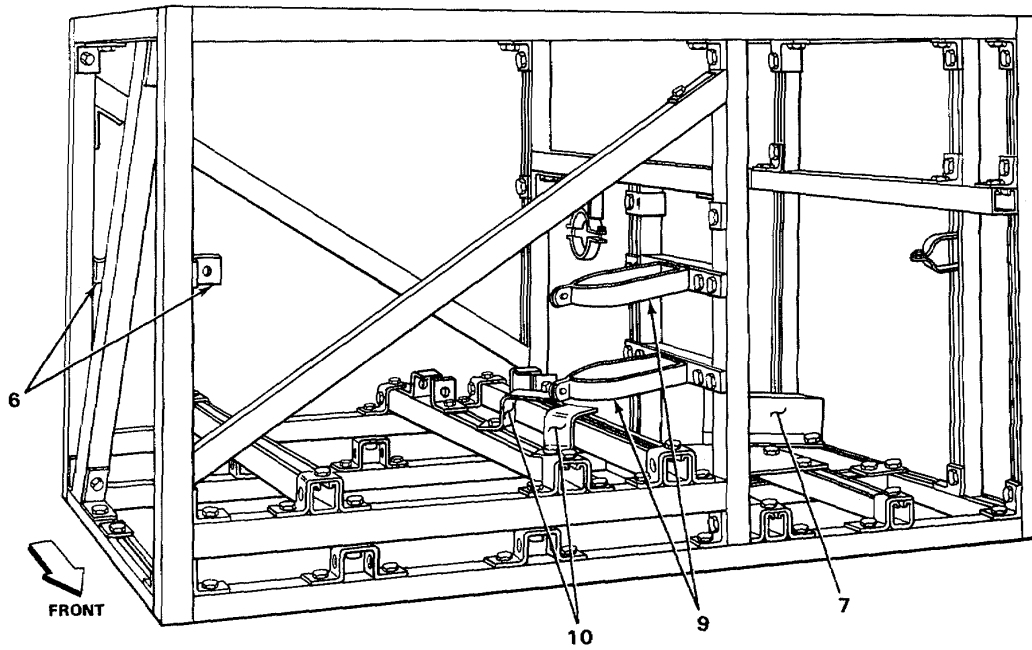

305NE208

4-52. ADMINISTRATIVE STORAGE. (CONT)

1. Remove hardware securing truss (1) marked REMOVE FOR PACKING AND UNPACKING and remove truss. Retain hardware for reinstallation.
2. Remove hardware securing bottom of clamp (2) to truss (1).
3. Using lifting device with suitable weight capacity, install elevation antenna drive in shipping frame and attach at three brace mounts (3) on bottom of shipping frame with associated
4. Install elevation actuator support arm in shipping frame and attach at brace mount (4) on bottom of shipping frame with associated hardware.
5. Using suitable lifting device, install azimuth antenna drive, with yoke assembly attached, in shipping frame and secure to mounting plate (5) using associated hardware. Attach each arm of yoke assembly to shipping frame with bracket (6) and associated hardware.
6. Install elevation yoke in shipping frame with yoke flange in left front corner of shipping frame. Attach yoke flange to bracket (7) using associated hardware.
7. Reinstall truss (1) previously removed and secure with associated hardware.
8. Using associated hardware, locate elevation yoke arm in top of clamp (2) and reinstall
9. Using bracket (8) and associated hardware, attach other elevation yoke arm to shipping frame. bottom of clamp.
10. Mount azimuth drive reducer in two ring clamps (9) with reducer flange under brackets (10) and secure with associated hardware.

SHIPPING DRUM NO. 5

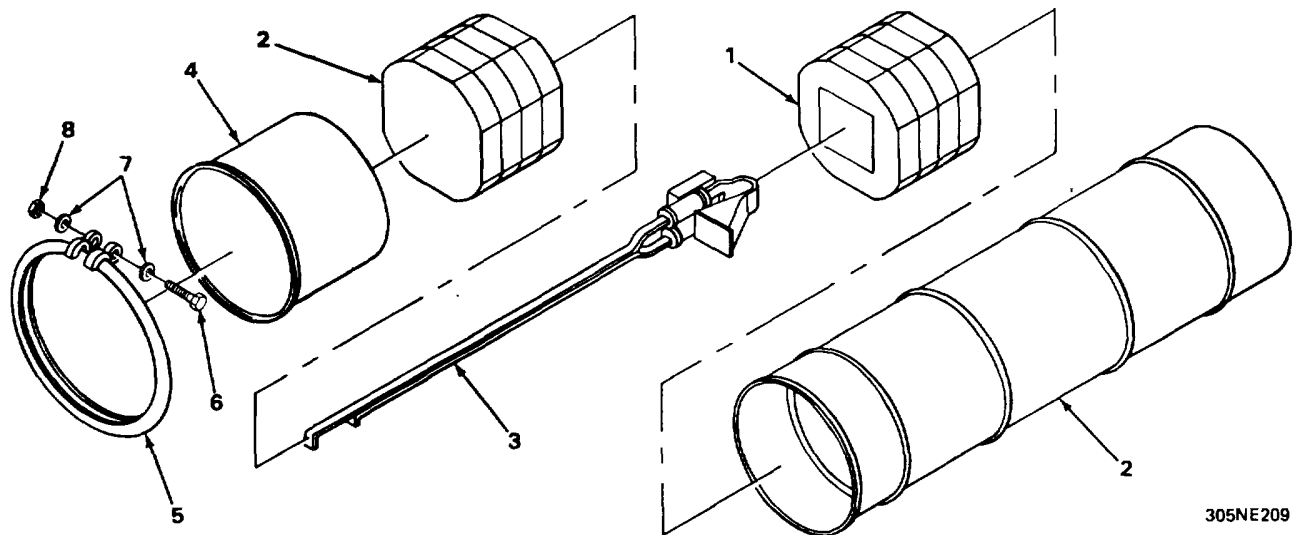

305NE209

1. Place packing foam (1) in bottom of shipping drum (2).
2. Install elevation horn and polarizer support (3) in shipping drum (2).
3. Place packing foam (1) on top of horn and polarizer support (3).

NOTE

If equipment is being packed for Intermediate storage (para 4-53), place 9 pounds (4.1 kg) of 16-unit desiccant bags, conforming to MIL-D-3564 class 1 and 2, in shipping drum.

4. Place cover (4) and securing ring (5) on shipping drum (2).
5. Tighten securing ring (5) using one bolt (6), two washers (7), and nut (8).

4-53. INTERMEDIATE STORAGE.

Intermediate storage is accomplished when radar set is to be stored between 46 and 180 days or when it is being shipped over long distances, such as by cargo vessel. It consists of packing receiver-transmitter group, control-indicator groups, shipping frames no. 1 and no. 2, shipping drums no. 5 and no. 6 and antenna pedestal and cable reels in wooden crates. Before performing intermediate storage, perform administrative storage procedures (para 4-52).

NOTE

The following crating procedure is typical for all components.

Before crating shipping frame no. 2, place 8 pounds (3.6 kg) of 16-unit desiccant bags, conforming to MIL-D-3464, in frame. Frame should then be encased in waterproof barrier paper, conforming to MIL-B-131.

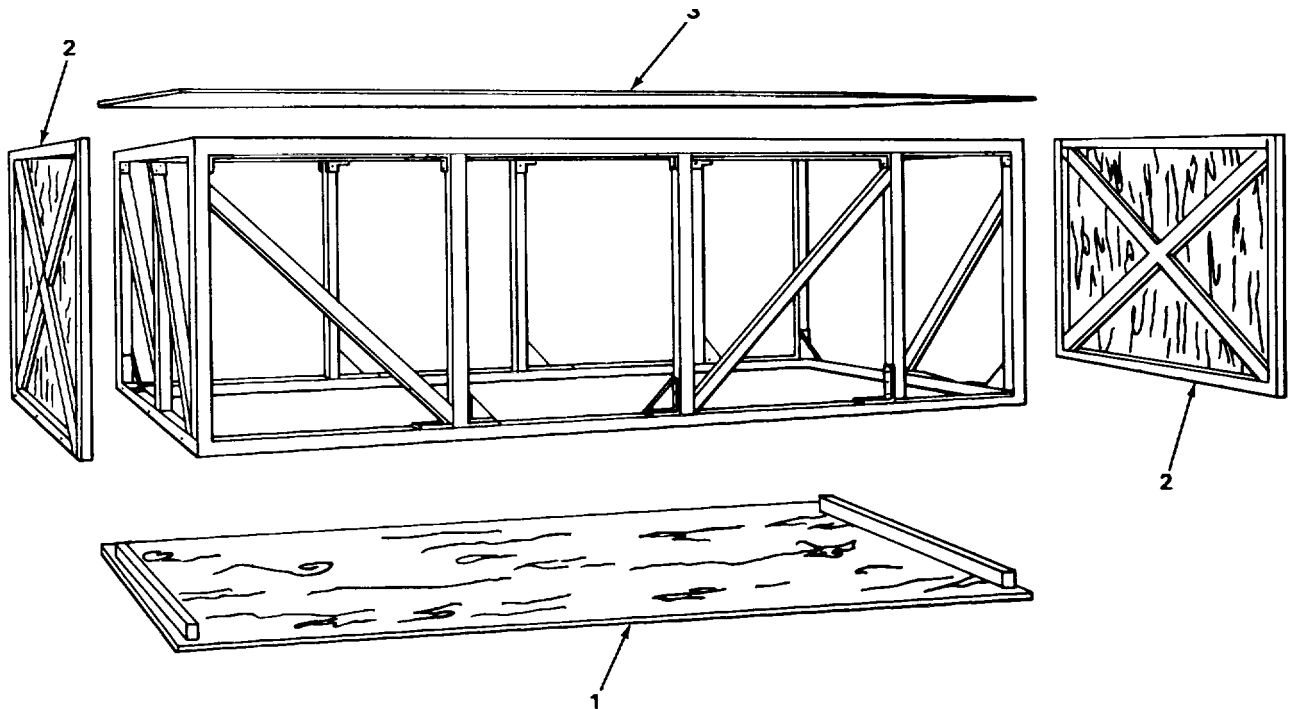

305NE210

1. Using lifting device with suitable weight capacity, place unit on bottom pallet (1).
2. Secure sides (2) together and to bottom pallet (1) by nailing.
3. Secure top (3) to sides (2) by nailing.

REFERENCES

A-1. SCOPE.

This appendix lists all pamphlets, army regulations, forms, service catalogs, service bulletins, technical bulletins, and technical manuals referenced in this manual.

A-2. ARMY REGULATIONS.

| | |
|--|-----------|
| Report of Transportation Discrepancies in Shipping Report..... | AR 55-38 |
| Accounting for Lost, Damaged, and Destroyed Property..... | AR 735-11 |

A-3. FIELD MANUALS.

| | |
|-----------------------------|----------|
| First Aid for Soldiers..... | FM 21-11 |
|-----------------------------|----------|

A-4. FORMS AND RECORDS.

| | |
|--|--------------|
| Equipment Inspection and Maintenance Worksheet | DA Form 2404 |
| Discrepancy in Shipping Report (DISREP) | SF 361 |
| Report of Discrepancy (ROD)..... | SF 364 |
| Quality Deficiency Report (Category II) | SF 368 |

A-5. PAMPHLETS.

| | |
|--|----------------|
| Consolidated Index of Army Publications and Blank Forms..... | DA PAM 310-1 |
| The Army Maintenance Management System (TAMMS) | DA PAM 738-750 |

A-6. SUPPLY BULLETINS.

| | |
|---|-----------|
| Painting and Preservation of Supplies Available for Field Use for Electronics Command Equipment | SB 11-573 |
| Preservation, Packaging, Packing and Marking Materials, Supplies, and Equipment used by the Army | SB 38-100 |

A-7. SUPPLY CATALOGS.

| | |
|---|-------------------|
| Tool Kit, Electronic Equipment TK-101/G | SC 5180-91-CL-R13 |
|---|-------------------|

A-8. TECHNICAL BULLETINS.

| | |
|--|------------|
| Identification of Radioactive Items in the Army Supply System | TB 43-0116 |
| Field Instructions for Painting and Preserving Electronics Command Equipment Including Camouflage Pattern Painting of Electrical Equipment Shelters..... | TB 43-0118 |
| Instructions for the Safe Handling and Identification of US Army Communications Electronics Command Managed Radioactive Items in the Army Supply System..... | TB 43-0122 |
| Safety Precautions for the Maintenance of Electrical/Electronics Equipment | TB 385-4 |

A-8 TECHNICAL BULLETINS. (CONT)

| | |
|--|------------|
| Safety Measures to be Observed when Installing and Using Whip Antennas, Field-Type Masts, Towers and Antennas and Metal Poles that are Used with Communications, Radar and Direction Finder Equipment | TB SIG 291 |
| Instructions for Repair of Radomes for Avionics Equipment | TB SIG 356 |

A-9. TECHNICAL MANUALS.

| | |
|---|--------------------|
| Operator's, Organizational, Field and Depot Maintenance Manual: Theodolite, Surveying, Directional: 2/10 Second Degree Graduation, 10.2 Inch Telescope W/Accessories (Wild Heerbrugg Model T-3) (NSN 6675-00-382-9140) and (Wild Heerbrugg Model T3-1969) (6675-00-411-5446) (TO 49A8-10-1) | TM 5-6675-231-15 |
| US Standard Flight Inspection Manual | TM 11-2557-25 |
| Organizational Maintenance Repair Parts and Special Tools Lists: Radar Set AN/TPN-18A (NSN 5840-01-070-9415) | TM 11-5840-281-20P |
| Operator's and Organizational Maintenance Manual Interrogator Set ANITPX-44 (NSN 5895-00-944-1314) | TM 11-5895-468-12 |
| Operator's and Organizational Maintenance Manual Landing Control Central, ANITSQ-71 B (NSN 5895-00-054-9366) | TM 11-5895-474-12 |
| Addendum | |
| Painting Instructions for Field Use | TM 43-0139 |
| Procedures for Destruction of Electronics Materiel to Prevent Enemy Use (Electronics Command) | TM 750-244-2 |

APPENDIX B**MAINTENANCE ALLOCATION****Section I INTRODUCTION****B-1. GENERAL.**

This appendix provides a summary of maintenance operations for the test set. It authorizes categories of maintenance for specific maintenance functions on repairable items and components and the tools and equipment required to perform each function. This appendix may be used as an aid in planning maintenance operations.

B-2. MAINTENANCE FUNCTIONS.

Maintenance functions will be limited to and defined as follows:

a. Inspect. To determine the serviceability of an item by comparing its physical, mechanical, and/or electrical characteristics with established standards through examination.

b. Test. To verify serviceability and to detect incipient failure by measuring the mechanical, or electrical characteristics of an item and comparing those characteristics with prescribed standards.

c. Service. Operations required periodically to keep an item in proper operating condition, ie, to clean (decontaminate); to preserve; to drain; to paint; or to replenish fuel, lubricants, chemical fluids, or compressed air supplies.

d. Adjust. To maintain, within prescribed limits, by bringing into proper or exact position, or by setting the operating characteristics to specified parameters.

e. Aline. To adjust specified variable elements of an item to bring about optimum or desired performance.

f. Calibrate. To determine and cause corrections or adjustments to be made on Instruments or test, measurement, and diagnostic equipment used in precision measurement. Consists of comparisons of two instruments, one of which is a certified standard of known accuracy, to detect and adjust any discrepancy in the accuracy of the instrument being compared.

g. Install. The act of emplacing, seating, or fixing into position an Item, part, or module (component or assembly) in a manner to allow the proper functioning of the equipment or system. h. Replace. The act of substituting a serviceable like-type part, subassembly, or module (component or assembly) for an unserviceable counterpart.

i. Repair. The application of maintenance services (inspect, test, service, adjust, aline, calibrate, install, or replace) or other maintenance actions (welding, grinding, riveting, straightening, facing, remachining, or resurfacing) to restore serviceability to an item by correcting specific damage, fault, malfunction, or failure in a part, subassembly, module (component or assembly), end item, or system.

j. Overhaul. That maintenance effort (service/action) necessary to restore an Item to a completely serviceable/operational condition as prescribed by maintenance standards (ie, DMWR) in appropriate technical publications. Overhaul is normally the highest degree of maintenance performed by the Army. Overhaul does not normally return an item to a like-new condition.

B-2. MAINTENANCE FUNCTIONS. (CONT)

k. Rebuild. Consists of those services necessary for the restoration of unserviceable equipment to a like-new condition in accordance with original manufacturing standards. Rebuild is the highest degree of materiel maintenance applied to Army equipment. The rebuild operation includes the act of returning to zero those age measurements (hours, miles, etc) considered in classifying Army equipment/components.

B-3. COLUMN ENTRIES.

a. Column 1, Group Number. Column 1 lists group numbers, the purpose of which is to identify components, assemblies, subassemblies, and modules with the next higher assembly.

b. Column 2, Component/Assembly. Column 2 contains the noun names of components, assemblies, subassemblies, and modules for which maintenance is authorized.

c. Column 3, Maintenance Function. Column 3 lists the functions to be performed on the item listed in column 2. When items are listed without maintenance functions, it is solely for purpose of having group numbers in the MAC and RPSTL coincide.

d. Column 4, Maintenance Category. Column 4 specifies, by the listing of a "work time" figure in the appropriate subcolumn (s), the lowest level of maintenance authorized to perform the function listed in column 3. This figure represents the active time required to perform that maintenance function at the indicated category of maintenance. If the number or complexity of the tasks within the listed maintenance function varies at different maintenance categories, appropriate "work time" figures will be shown for each category. The number of task-hours specified by the "work time" figure represents the average time required to restore an item (assembly, subassembly, component, module, end item, or system) to a serviceable condition under typical field operating conditions. This time includes preparation time, troubleshooting time, and quality assurance/quality control time in addition to the time required to perform the specific tasks identified for the maintenance functions authorized in the maintenance allocation chart. Subcolumns of column 4 are as follows:

- C - Operator/Crew
- O - Organizational
- F - Direct Support
- H - General Support
- D - Depot

e. Column 5, Tools and Equipment. Column 5 specifies by code those common tool sets (not individual tools) and special tools, test, and support equipment required to perform the designated function.

f. Column 6, Remarks. Column 6 contains an alphabetic code that leads to the remark in section IV, Remarks, which is pertinent to the item opposite the particular code.

B-4. TOOL AND TEST EQUIPMENT REQUIREMENTS.

a. Tool or Test Equipment Reference Code. The numbers in this column coincide with the numbers used in the tools and equipment column of the MAC. The numbers indicate the applicable tool or test equipment for the maintenance functions.

b. Maintenance Category. The codes in this column indicate the maintenance categories allocated the tool or test equipment.

B-4 TOOL AND TEST EQUIPMENT REQUIREMENTS. (CONT)

- c. Nomenclature. This column lists the noun name and nomenclature of the tools and test equipment required to perform the maintenance functions.
- d. National/NATO Stock Number. This column lists the National/NATO stock number of the
- e. Tool Number. This column lists the manufacturer's part number of the tool followed by the federal supply code for manufacturers in parentheses..

B-5. REMARKS.

- a. Reference Code. This code refers to the appropriate item in section II, column 6.
- b. Remarks. This column provides the required explanatory information necessary to clarify items appearing in section II.

Section II MAINTENANCE ALLOCATION CHART FOR AN/TPN-18A

| (1) GROUP NUMBER | (2) COMPONENT/ ASSEMBLY | (3) MAINTENANCE FUNCTION | (4) MAINTENANCE CATEGORY | | | | | (5) TOOLS AND EQPT | (6) REMARKS |
|------------------------|-------------------------------|--------------------------------|-----------------------------|-----|-----|---|---|--|----------------|
| | | | C | O | F | H | D | | |
| 00 | RADAR SET AN/TPN-18A | Inspect | | 0.5 | | | | | |
| | | Test | | 0.5 | | | | | |
| | | Service | | 0.5 | | | | 2,7,13, 33 | |
| | | Adjust | | 0.2 | | | | 2 | |
| | | Aline | | 2 | | | | 2 | |
| | | Install | | 8.5 | | | | 2,7,13, 33 through 36,70, 71 | A |
| 01 | RADAR SET GROUP | Repair | | | 0.5 | | 1340 | | B |
| | | Overhaul | | | | | 1,3 through 32,34 through 105 | | |
| | | Inspect | | 0.3 | | | | | |
| | | Test | | 0.5 | | | | | |
| | | Service | | 0.3 | | | | | |
| | | Aline | | 0.5 | | | | | |
| Install | | 6.5 | | | | 2 | A | | |
| Repair | | 0.3 | | | | 2 | C | | |
| | | Repair | | | 0.5 | | 1,3 | B | |

| (1) GROUP NUMBER | (2) COMPONENT/ ASSEMBLY | (3) MAINTENANCE FUNCTION | (4) MAINTENANCE CATEGORY | | | | | (5) TOOLS AND EQPT | (6) REMARKS |
|------------------------|---|---|-----------------------------|-----------------------|------------|-----|---|---|----------------|
| | | | C | O | F | H | D | | |
| 0101 | COUPLER, DIRECTIONAL | Replace Repair | | 0.3 | | | | 1 1 | |
| 0102 | AZIMUTH ANTENNA AND YOKE ANTENNA AS-1292/TPN-8 | Replace Repair Repair | | 0.3 0.5 | | | | 1,33 4 37 thru 47 | C |
| 010201 | ACTUATOR, ANTENNA SERVO (AZ) | Replace Replace Repair | | 0.5 | | | | 2 1 1,12 | |
| 010202 | HORN AND POLA- RIZER,AZIMUTH ANTENNA | Replace Repair | | | 0.5 | | | 1 1,12 | |
| 0103 | YOKE AND ELEVATION ANTENNA AS-1281/TPN-8 | Replace Repair Repair | | | 0.3 0.5 | | | 1 1 4 37 thru 47 | C |
| 010301 | ACTUATOR, ANTENNA SERVO (EL) | Replace Repair | | 0.5 | | | | 2 1,12 | |
| 010302 | HORN AND POLARIZER, ELEVATION ANTENNA | Replace Repair | | 0.5 | | | | 1 1,2 | |
| 0104 | DRIVE, ANTENNA TG-230/TPN-18 | Inspect Service Adjust Replace Repair | | 0.2 0.2 0.2 | | 1 | | 2,80 thru 80 3,12,80 thru 89 1 1,80 thru 89 | H |
| 010401 | GEARCASE- MOTOR, AZIMUTH DRIVE | Inspect Service Replace Repair | | 0.2 0.2 | | 0.5 | | 2 1 1 | |

| (1) GROUP NUMBER | (2) COMPONENT/ ASSEMBLY | (3) MAINTENANCE FUNCTION | (4) MAINTENANCE CATEGORY | | | | | (5) TOOLS AND EQPT | (6) REMARKS |
|------------------------|--|--|-----------------------------|--|-----------|-----|---|---|----------------|
| | | | C | O | F | H | D | | |
| 01040101 | MOTOR; CONTROL (ANTENNA DRIVE SERVO) | Replace Repair | | | 0.5 | 0.5 | | 1 1,12 | |
| 010402 | COUPLER, ASSEMBLY, ROTARY, AZIMUTH | Replace Repair | | | 0.5 | 0.5 | | 1 1,12 | |
| 0105 | DRIVE, ANTENNA TG-231/TPN-18 | Inspect Service Adjust Replace Repair | | 0.2 0.2 0.2 | 1 | | | 2,80 thru 89 3,13,80 thru 89 1 1 | H |
| 010501 | MOTOR, AC (EL DRIVE) | Replace Repair | | | 0.5 | 0.5 | | 1 1,12 | |
| 010502 | ACTUATOR ASSEMBLY (EL) | Replace Repair | | | 0.5 | 0.5 | | 1 1,12 | |
| 01050201 | ACTUATOR, ELECTRO- MECHANICAL (EL) 86490-2 | Replace Repair | | | 0.5 | 0.5 | | 1 1,12 | |
| 010503 | COUPLER ASSEMBLY ROTARY ELEVATION 102729 | Replace Repair | | | 0.5 | 0.5 | | 1 1,12 | |
| 0106 | PEDESTAL, ANTENNA AB-738/TPN-8 100202 | Inspect Service Replace Repair | | 0.2 0.2 0.5 1 | | | | 2 2 2 | |
| 0107 | RECEIVER- TRANSMITTER GROUP 170282-1 | Inspect Test Service Adjust Aline Replace Repair | | 0.2 0.3 0.2 0.2 0.2 0.3 | | 0.5 | | 2,7.13 2 2,13 2,13 2 | D E B |

| (1) GROUP NUMBER | (2) COMPONENT/ ASSEMBLY | (3) MAINTENANCE FUNCTION | (4) MAINTENANCE CATEGORY | | | | | (5) TOOLS AND EQPT | (6) REMARKS |
|--------------------------------------|---|--------------------------------|-----------------------------|-----|-----|---|-----|---|----------------|
| | | | C | O | F | H | D | | |
| 0107 | CLINOMETER ANTENNA | Inspect | | 0.2 | | | | | |
| | | Replace | | 0.3 | | | | | |
| | TELESCOPE 117846 | Inspect | | 0.2 | | | | | |
| 010701 | EXTRACTOR CIRCUIT CARD G500004S3 | Inspect | | 0.2 | | | | | |
| | | Replace | | 0.3 | | | | | |
| | RECEIVER- TRANSMITTER RADAR RT-1172/ TPN-18 170283-1 | Inspect | | 02 | 0.2 | | | 4,6,8 thru 12, 18,19 29,79 | |
| | | Test | | | | | 0.2 | 22,25, 27,29, 37,49, 52,54, 57,58, 59,62, 79,92, 94,95 96,99, 100,101 2 | |
| | | Service | | 0.2 | | | | | |
| | | Adjust | | | 0.2 | | | 3,4,105 | |
| | | Aline | | 0.2 | | | | 2,13,67 | D |
| | | Replace | | 0.3 | | | | 2,80 | E |
| | | Repair | | | 0.5 | | | thru 89 1 | B |
| | TR LIMITER 140879-1 | Inspect | | 0.2 | | | | | |
| Replace | | | 0.3 | | | | 2 | | |
| AMPLIFIER,GAAS FET 164100-1 | Inspect | | 0.2 | | | | 2 | | |
| | Replace | | 0.3 | | | | 2 | | |
| POWER SUPPLY + 12 VDC 164101-1 | Inspect | | 0.2 | | | | | | |
| | Replace | | 0.3 | | | | 2 | | |
| POWER SUPPLY 15 VDC 164102-1 | Inspect | | 0.2 | | | | | | |
| | Replace | | 0.2 | | | | 1 | | |

| (1) GROUP NUMBER | (2) COMPONENT/ ASSEMBLY | (3) MAINTENANCE FUNCTION | (4) MAINTENANCE CATEGORY | | | | | (5) TOOLS AND EQPT | (6) REMARKS |
|------------------------|--|--------------------------------|-----------------------------|-----|-----|-----|-----|---|----------------|
| | | | C | O | F | H | D | | |
| 01070101 | RECEIVER RADAR R-1938/ TPN-18 139992-1 | Inspect | | 0.2 | | | | | |
| | | Test | | | 0.2 | | | 4,5,29 | |
| | | Adjust | | | 0.2 | | | 3 | |
| | | Aline | | | 0.3 | | | 3,12,105 | |
| | | Replace | | | 0.3 | | | 1 | |
| | | Repair | | | 0.5 | | 0.5 | 1,9,57 59,62 | B |
| | OSCILLATOR, LOCAL 140208-1 | Inspect | | 0.2 | | | | | |
| | | Replace | | | | 0.3 | | 3 | |
| | | Adjust | | 0.2 | | | | | |
| 010701- 0101 | MIXER,SIGNAL RF 170235-1 | Replace | | | 0.3 | | | 3 | |
| | | Repair | | | 0.5 | | | 3 | |
| | | Adjust | | 0.2 | | | | | |
| 010701- 0102 | AMPLIFIER, IF, LIN/LOG | Replace | | | 0.3 | | | 3,12,105 | |
| | | Repair | | | | | 1 | 5,6,12 15,16, 19,23, 27,49, 53,54, 92,97, 98,102 | |
| 010701- 0103 | CONVERTER, PREAMPLIFIER 170230-1 | Adjust | | | 0.3 | | | 3 | |
| | | Replace | | | 0.3 | | | 3 | |
| | | Repair | | | | | 1 | 5,6,8 12,15, 16,18 19,20 23,27, 49,53, 65,97, 98,102 | |
| 010701- 0104 | AMPLIFIER, LOG IF 170232-1 | Replace | | | 0.3 | | | 3 | |
| | | Repair | | | | | 1 | 5,12,15, 16,19, 20,23, 26,27 49,64, 92,97, 98,102 | |

| (1) GROUP NUMBER | (2) COMPONENT/ ASSEMBLY | (3) MAINTENANCE FUNCTION | (4) MAINTENANCE CATEGORY | | | | | (5) TOOLS AND EQPT | (6) REMARKS |
|------------------------|---|--------------------------------|-----------------------------|---|------------|-----|---|--|----------------|
| | | | C | O | F | H | D | | |
| 010701-0105 | AMPLIFIER, GAIN CONTROL 17-0238-1 | Adjust Replace Repair | | | 0.3 0.3 | | | 3 3 1 5,6,12, 15,16, 19,20, 23,27, 49,65, 92,97, 98,102 | |
| 010701-0106 | REGULATOR, LO 140612-1 | Adjust Replace Repair | | | 0.3 0.3 | | | 3 3 1 1,9,57, 59,62, 75 | |
| 010701-0107 | DELAY LINE, IF 1406-13-1 | Replace Repair Repair | | | 0.3 | 1.0 | | 3 1,4 1 14,15,23 | |
| 01070102 | CARD CAGE, STRUCTURAL, RECEIVER/ TRANSMITTER POWER SUPPLY 140962-1 | Replace Repair | | | | 2.5 | | 1 1 | |
| 01070103 | GENERATOR, STC GATE 140686-1 | Adjust Replace Repair | | | 0.2 0.3 | | | 3 3 1 4,9,14, 57,59, 60,61, 67,90, 91,92 | |
| 01070104 | GENERATOR, STC 17023-1 | Adjust Replace Repair | | | 0.2 0.3 | | | 3 3 1 4,9,14, 57,59, 60,61, 67,90, 91,92 | |

| (1) GROUP NUMBER | (2) COMPONENT/ ASSEMBLY | (3) MAINTENANCE FUNCTION | (4) MAINTENANCE CATEGORY | | | | | (5) TOOLS AND EQPT | (6) REMARKS |
|------------------------|--|--|-----------------------------|-------------------|-------------------|---|---|--|----------------|
| | | | C | O | F | H | D | | |
| 01070105 | AMPLIFIER VIDEO 170233-1 | Adjust Replace Repair | | | 0.2 0.3 | | | 3 3 4,9,12 13,57, 59,62, 67 | |
| 01070106 | PREAMPLIFIER, ELECTRONIC CONTROL 139750-1 | Adjust Aline Replace Repair | | | 0.2 0.3 0.3 | | | 3 12,105 3 9,12,22, 28,57, 59,60, 61,67, 90,91, 92 | |
| 01070107 | REGULATOR, VOLTAGE, 35V | Adjust Replace Repair | | 0.2 0.3 | | | | 2,13 2,13 4,9,12, 22,57, 59,62, 67 | |
| 01070108 | FILTER, ELECTRONIC 140502-1 | Inspect Adjust Replace Repair | | 0.1 0.2 0.3 | | | | 2 2 4,9,12, 24,57, 59,60, 61,67, 90,91, 92 | |
| 01070109 | RECEIVER, RECEIVER- TRANSMITTER 140654-1 | Replace Repair | | 0.3 | | | | 2 1,9,12, 57,59, 62 | |
| 01070110 | CARD CAGE, STRUCTURAL, TRANSMITTER 170239-1 | Replace Repair | | | 0.3 | 1 | | 1 1 | |

| (1) GROUP NUMBER | (2) COMPONENT/ ASSEMBLY | (3) MAINTENANCE FUNCTION | (4) MAINTENANCE CATEGORY | | | | | (5) TOOLS AND EQPT | (6) REMARKS |
|------------------------|--|---|-----------------------------|---|--|---|---|--|----------------|
| | | | C | O | F | H | D | | |
| 0107011 | MODULATOR, SCR 140523-1 | Replace Repair | | | 0.3 | | | 3 1,9,57, 59,62, 69,104 | |
| 01070112 | CHARGER, SCR 140524-1 | Replace Repair | | | 0.3 | | | 3 1,9,57, 59,62, 69,104 | |
| 01070113 | OVERLOAD PROTECTOR, POWER SUPPLY 140550-1 | Replace Repair | | | 0.3 | | | 3 1,9,57, 59,62 | |
| 01070114 | REGULATOR, DEQ'ING 140630-1 | Adjust Replace Repair | | | 0.2 0.3 | | | 3 3 4,9,17, 57,59, 62 | |
| 01070115 | RESISTOR ASSEMBLY POWER 140655-1 | Replace Repair | | | 0.3 | | | 3 1,9,57, 59,62 | |
| 01070116 | AMPLIFIER, ELECTRONIC CONTROL | Adjust Replace Repair | | | 0.2 0.3 | | | 3 3 4,9,12, 57,59, 62,76, 105 | |
| 01070117 | CONTROL, REMOTE, SWITCHING C-10620/TPN-18 170284-1 | Inspect Test Adjust Aline Replace Repair Repair | | | 0.2 0.2 0.2 0.3 0.3 0.5 | | | 12 3 12 3 1,9 57,59, 60,61, 75,90, 91,92 | C |

| (1) GROUP NUMBER | (2) COMPONENT/ ASSEMBLY | (3) MAINTENANCE FUNCTION | (4) MAINTENANCE CATEGORY | | | | | (5) TOOLS AND EQPT | (6) REMARKS |
|------------------------|--|--|-----------------------------|-----|------------------------|-----|---|--|----------------|
| | | | C | O | F | H | D | | |
| 01070118 | CONTROL- INDICATOR C-9763/TPN-18 140526-1 | Test Adjust Aline Replace Repair Repair | | 0.2 | 0.3 0.3 0.3 1 | | | 72 3 12,105 3 1,9 57,59,62 | |
| 0107 011801 | GENERATOR, TRIGGER 140525-1 | Adjust Aline Replace Repair | | | 0.2 0.3 0.3 | | | 3 12,105 1 4,9,14, 24,57, 59,62 | |
| 0107 011802 | DRIVER, LAMP 140527-1 | Replace Repair | | | 0.3 | | 1 | 1 9,57,59, 62,74 | |
| 0107- 011803 | GENERATOR TIMING, TYPE I 140551-1 | Replace Repair | | | 0.3 | | 1 | 1 9,57,59, 62 | |
| 0107- 011804 | CONTROL, TRANSMITTER, TYPE 1 140552-1 | Replace Repair | | | 0.3 | | 1 | 1 9,57,59, 62 | |
| 0107 11805 | GENERATOR, TIMING, TYPE II 140636-1 | Replace Repair | | | 0.3 | | 1 | 1 9,57,59, 62 | |
| 0107- 011806 | CONTROL, TRANSMITTER, TYPE II 140637-1 | Replace Repair | | | 0.3 | | 1 | 1 9,57,59, 62 | |
| 0107- 011807 | GENERATOR TEST 140638-1 | Replace Repair | | | 0.3 | | 1 | 1 9,57,59, 62 | |
| 0107- 011808 | CARD CAGE, CONTROL MONITOR, TRANSMITTER 140660-1 | Replace Repair | | | | 0.3 | 1 | 1 1 | |

| (1) GROUP NUMBER | (2) COMPONENT/ ASSEMBLY | (3) MAINTENANCE FUNCTION | (4) MAINTENANCE CATEGORY | | | | | (5) TOOLS AND EQPT | (6) REMARKS |
|------------------------|---|---|-----------------------------|---------------------------------|-------------------|---|---|--|----------------|
| | | | C | O | F | H | D | | |
| 01070119 | POWER SUPPLY, LOW VOLTAGE 140647-1 | Adjust Replace Repair Repair | | 0.3 | 0.2 0.5 | | | 3 2 12 22,57, 66,93 | |
| 01070120 | CONTROL- INDICATOR C-9762/TPN-18 139995-1 | Test Adjust Aline Calibrate Replace Repair | | 0.2 0.3 0.3 0.3 | 0.2 0.3 0.3 | | | 3 12,105 12 2 1,9 57,59, 60,61, 90,91, 92 | E B |
| 01070121 | ADAPTER, CARD TEST, RCVR/XMTR 100212 | Replace Repair | | | 0.3 | | | 3 1 | G |
| 02 | CONTROL- INDICATOR GROUP 170277-1 | Inspect Test Service Adjust Aline Calibrate Replace Repair | | 0.1 0.2 0.1 0.2 0.5 | 0.3 0.3 0.5 | | | 2 2 3 3 2 1 | E |
| 0201 | CONTROL- INDICATOR C-6988A/TPN-18 170278-1 | Inspect Test Service Adjust Aline Replace Repair | | 0.1 0.2 0.1 0.2 0.5 | 0.3 | | | 2 2 3 2 4,5,12, 14,21, 22,24, 57,59, 60,61, 63,90, 91,92 | E |

| (1) GROUP NUMBER | (2) COMPONENT/ ASSEMBLY | (3) MAINTENANCE FUNCTION | (4) MAINTENANCE CATEGORY | | | | | (5) TOOLS AND EQPT | (6) REMARKS |
|------------------------|---|---|-----------------------------|--|------------|---|---|---|----------------|
| | | | C | O | F | H | D | | |
| 020101 | MONITOR POWER SUPPLY 139998-1 | Inspect Replace Repair | | 0.1 0.3 | | | | 1 2 4,5,12, 14,60, 63,77 | |
| 020102 | AMPLIFIER- REGULATOR, ROTATING COIL 170243-1 | Adjust Replace Repair | | | 0.2 0.3 | | | 1 3 3 4,12,14, 60,63 | |
| 020103 | GENERATOR PULSE 0-1690/ TPN-18 170279-1 | Inspect Test Service Adjust Aline Calibrate Replace Repair Repair Repair | | 0.1 0.2 0.1 0.2 0.3 0.3 0.3 0.6 | | | 1 | 68 2 2 3 3 2 3 1,9 1,9,57, 59,60, 61,90, 91,92 | E F F |
| 02010301 | GENERATOR, SWEEP 139752-1 | Adjust Replace Repair | | | 0.2 0.3 | | | 1 3 3 4,14,60, 63,68 | |
| 02010302 | GENERATOR, TRIGGER DELAY 139753-1 | Adjust Replace Repair | | 0.2 | 0.2 0.3 | | | 1 3 3 4,12,14, 60,63, 68 | I |
| 02010303 | OSCILLATOR, RANGE MARK 170254-1 | Adjust Replace Repair | | | 0.2 0.3 | | | 1 3 3 4,12,14 60,63, 68 | |

| (1) GROUP NUMBER | (2) COMPONENT/ ASSEMBLY | (3) MAINTENANCE FUNCTION | (4) MAINTENANCE CATEGORY | | | | | (5) TOOLS AND EQPT | (6) REMARKS |
|------------------------|--|--------------------------------|-----------------------------|---|------------|---|---|---|----------------|
| | | | C | O | F | H | D | | |
| 02010304 | GENERATOR, AZ-EL BLANKING PULSE 139754-1 | Adjust Replace Repair | | | 0.2 0.3 | | | 3 3 9,12,57, 59,60, 61,68, 90,91, 92 | |
| 02010305 | GENERATOR, RANGE MARK 139755-1 | Adjust Replace Repair | | | 0.2 0.3 | | | 3 3 4,12,14, 60,63, 68,103 | |
| 02010306 | GENERATOR, SAWTOOTH 139756-1 | Adjust Replace Repair | | | 0.2 0.3 | | | 3 3 4,9,12, 14,57, 59,60, 61,68, 90,91, 92 | |
| 02010307 | COMPARATOR, SAWTOOTH 139757-1 | Adjust Replace Repair | | | 0.3 0.3 | | | 3 3 4,9,12 14,57, 59,60, 61,68, 90,91, 92 | |
| 02010308 | GENERATOR, CURSOR 139758-1 | Adjust Replace Repair | | | 0.2 0.3 | | | 3 3 4,9,12, 14,57, 59,60, 61,68, 90,91, 92 | |

| (1) GROUP NUMBER | (2) COMPONENT/ ASSEMBLY | (3) MAINTENANCE FUNCTION | (4) MAINTENANCE CATEGORY | | | | | (5) TOOLS AND EQPT | (6) REMARKS |
|------------------------|--|---|-----------------------------|--------------------------|------------|---|---|--|----------------|
| | | | C | O | F | H | D | | |
| 02010309 | CONTROL CURSOR 139759-1 | Adjust Replace Repair | | | 0.2 0.3 | | | 3 3 4,9,12, 14,24, 57,59, 60, 61 68,90, 91,92, 105 | |
| 02010310 | HEIGHT FINDER ASSEMBLY, ALTITUDE 103061-1 | Replace Repair | | | 0.3 | | 1 | 3 1 | |
| 020104 | POWER SUPPLY PP-7158/TPN-18 139760-1 | Inspect Test Adjust Aline Replace Repair Repair Repair | | 0.1 0.2 0.2 0.3 | 0.3 0.5 | | 1 | 2 2 3 3 1 60,63, 73 | F |
| 02010401 | REGULATOR, VOLTAGE, 35V 139751-1 | Adjust Replace Repair | | 0.2 0.3 | | | 1 | 2,13 2,13 4,12,22, 57,60, 63,67 | |
| 02010402 | REGULATOR, VOLTAGE, 12V 170259-1 | Adjust Replace Repair | | 0.2 0.3 | | | 2 | 2,13 2,13 4,5,22, 57,63 | |
| 02010403 | RECTIFIER, INDICATOR 170257-1 | Replace Repair | | 0.3 | | | 1 | 2,13 12,57, 60,63, 67 | |
| 02010404 | REGULATOR, VOLTAGE, 18V 139761-1 | Adjust Replace Repair | | 0.2 0.3 | | | 1 | 2,13 2,13 4,12, 57,60, 63,67 | |

| (1) GROUP NUMBER | (2) COMPONENT/ ASSEMBLY | (3) MAINTENANCE FUNCTION | (4) MAINTENANCE CATEGORY | | | | | (5) TOOLS AND EQPT | (6) REMARKS | |
|------------------------|---|--------------------------------|-----------------------------|------------|------------|---|---|-----------------------------|---|---|
| | | | C | O | F | H | D | | | |
| 02010405 | AMPLIFIER, FIXED COIL 139762-1 | Adjust Replace Repair | | 0.2 0.3 | | | | 1 | 2,13 2,13 4,5,9, 12,17, 21,22, 57,59, 60,61, 67,90, 91,92 | |
| 020105 | MIXER- AMPLIFIER 139763-1 | Adjust Replace Repair | | | 0.2 0.3 | | | 1 | 3 3 4,9,12, 105,14, 57,59, 60,61, 90,91, 92 | |
| 020106 | DEFLECTOIN YOKE, INDICATOR 100250 | Replace Repair | | | 0.3 | | | 1 | 3 1 | |
| 020107 | PPI SERVO ASSEMBLY 164150-1 | Replace Repair | | | 0.3 | | | 1 | 3 1 | |
| 020108 | ADAPTER CARD TEST, CONT/IND 10025` | Replace Repair | | | 0.3 | | | 1 | 3 1 | G |
| 03 | SELECTOR, SIGNAL MONITOR SA-2035/TPN-18 139997-1 | Replace Repair | | | 0.3 | | | 1 | 3 4,5,12, 14 | |
| 04 | CABLE INSTALLATION, INTERCONNECT- ING 180975-1 | Test Replace Repair | | 0.2 0.3 | | | 1 | | 13 2 1,3 | |
| 05 | SIMULATOR, RADAR TARGET 100253 | Inspect Replace Repair | | 0.1 0.3 | 0.5 | | | | 2 1,3 | |

**Section III TOOL AND TEST EQUIPMENT REQUIREMENTS
FOR RADAR SET ANITPN-18A**

| TOOL OR TEST EQUIPMENT REF CODE | MAINTENANCE CATEGORY | NOMENCLATURE | NATIONAL/NATO STOCK NUMBER | TOOL NUMBER |
|---------------------------------|----------------------|---|----------------------------|-------------|
| 1 | F,H,D | TOOL KIT, ELECTRONIC EQUIPMENT TK-1001G | 5180-00-605-0079 | |
| 2 | O | TOOL KIT, ELECTRONIC EQUIPMENT TK-1011G | 518000-064-5178 | |
| 3 | F,H,D | TOOL KIT, ELECTRONIC EQUIPMENT TK-1051/G | 5180-00-610-8177 | |
| 4 | F,H,D | OSCILLOSCOPE AN/USM-281A OR 281C* | 6625-00-106-9622 | |
| 5 | F,H,D | VOLTMETER, DIFFERENTIAL ME-202A/U OR TS-2843U* | 6625-00-709-0288 | |
| 6 | F,H,D | SPECTRUM ANALYZER AN/UPM-84A OR IP-1216PGR* | 6625-00-411-3072 | |
| 7 | O,F,H,D | ECHO BOX TS-488/UP* | 6625-00-5197594 | |
| 8 | F,H,D | POWER METER ME-441/U* (SEE NOTE J) | 6625-00-436-4833 | |
| 9 | F,H,D | DUMMY LOAD DA-148/U (2 EA) | 5985-00-538-7329 | |
| 10 | F,H,D | CRYSTAL DETECTOR H P-423A | 5820-00-877-7148 | |
| 11 | F,H,D | HIGH VOLTAGE PROBE P-6015* | 6625-00-879-4627 | |
| 12 | F,H,D | VOLTMETER, DIGITAL AN/USM-451, AN/GSM-64, OR ME-518U* | 6625-01-060-6804 | |
| 13 | O | VOLTMETER TS-352B/U OR AN/USM-223* | 6625-00-553-0142 | |
| 14 | D | PULSE GENERATOR AN/UPM-15A (3 EA) OR SG-1105U* | 6625-00-682-2531 | |

**TOOL AND TEST EQUIPMENT REQUIREMENTS FOR
RADAR SET AN/TPN-18A (CONT)**

| TOOL OR TEST EQUIPMENT REF CODE | MAINTENANCE CATEGORY | NOMENCLATURE | NATIONAL/ NATO STOCK NUMBER | TOOL NUMBER |
|---------------------------------|----------------------|--|-----------------------------|-------------|
| 15 | D | SIGNAL GENERATOR AN/USM-44A | 6625-00-539-9635 | |
| 16 | D | SWEEP GENERATOR ANIUSM-203 OR MX-8364A P * | 6625-01-074-4337 | |
| 17 | D | SINE WAVE OSCILLATOR AN/USM-205 OR SG-1128U* | 6625-01-007-4796 | |
| 18 | F,H,D | THERMISTOR MOUNT HP478A *- | 6625-00-886-1955 | |
| 19 | F,H,D | COUNTER, ELECTRONIC CP-772A/U OR TD- 1225MI(/)1U* | 6625-00-973-4837 | |
| 20 | F,H,D | CONVERTER PLUG-IN CV- 2002/U FOR CP-772A/U OR TD-1225(V)1/U* | 6625-00-226-3433 | |
| 21 | D | AMMETER ME-156/U OR M E-489U * | 6625-00-620-1405 | |
| 22 | D | VOLTMETER AC RMS ME-2071U OR ME-459U* | 6625-00-557-8261 | |
| 23 | D | VOLTMETER RF ME-247/U | 6625-00-973-2294 | |
| 24 | D | FUNCTION GENERATOR SG- 321/U OR AN/USM-127* | 6625-00-674-7097 | |
| 25 | D | NOISE SOURCE HP H347A* | 6625-00-887-7782 | |
| 26 | D | PULSE GENERATOR SG-3661U | 6625-00-168-0471 | |
| 27 | D | NOISE FIGURE METER TS-24361G | 6625-00-892-5286 | |
| 28 | D | BRIDGE ZM-4/U OR ZM-71U* | 6615-00-500-0937 | |

| TOOL OR TEST EQUIPMENT REF CODE | MAINTENANCE CATEGORY | NOMENCLATURE | NATIONAL/ NATO STOCK NUMBER | TOOL NUMBER |
|---------------------------------|----------------------|---|-----------------------------|-------------|
| 29 | F,H,D | SIGNAL GENERATOR AN/URM-206 OR SG-944U * | 6625-01-077-8503 | |
| 30 | D | SWEEP GENERATOR HP-8690B (M88364)* | 6625-00-442-3470 | |
| 31 | D | PLUG-IN HP-8694B FOR HP-8690B (PL 1304)* | 6625-00-444-2327 | |
| 32 | D | TOOL KIT, PRINTED CIRCUIT MK-772 | 5999-00-757-7042 | |
| 33 | O,F,H,D | WRENCH KIT (BOX AND OPEN-END) | 5120-00-585-8728 | |
| 34 | O,F,H,D | STOPWATCH | 6645-00-240-7162 | |
| 35 | O,F,H,D | MEASURING TAPE, 100 FT. | 5210-00-221-1882 | |
| 36 | O,F,H,D | THEODOLITE T-3 (OR TRANSIT) | 6675-00-382-9140 | |
| 37 | D | FREQUENCY METER HP-H532A FR-1941U* | 6625-00-730-8570 | |
| 38 | D | VSWR METER ANIUPM-108 OR AN/USM-261 * | 6625-00-682-4494 | |
| 39 | D | THERMISTOR MOUNT HP-H486Aw/11528A (MX-9158/U) | 6625-00-916-6791 | |
| 40 | D | ATTENUATOR, VARIABLE HP-H375A | 6625-00-679-0624 | |
| 41 | D | PATTERN RECORDER, SCIENTIFIC ATLANTA MODEL 121-B | | |
| 42 | D | X-BAND TRANSMITTER 9-9.6 GHZ PRF VAR. 1750-1850 PPS | | |
| 43 | D | TRANSMITTER ANTENNA, REFLECTOR AND BEARING MOUNT | | |

**TOOL AND TEST EQUIPMENT REQUIREMENTS FOR
RADAR SET AN/TPN-18A (CONT)**

| TOOL OR TEST EQUIPMENT REF CODE | MAINTENANCE CATEGORY | NOMENCLATURE | NATIONAL/NATO STOCK NUMBER | TOOL NUMBER |
|---------------------------------|----------------------|--|----------------------------|-------------|
| 44 | D | UNIVERSAL TEST MOUNT | | |
| 45 | D | YOKE ADAPTER | | |
| 46 | D | X-BAND STANDARD CALIBRATED GAIN HORN | | |
| 47 | D | H-BAND ROTARY JOINT | | |
| 48 | D | ATTENUATOR, VARIABLE, WAVEGUIDE HP-H382A | 6625-00-679-0625 | |
| 49 | D | ATTENUATOR, STEP CN-796/U | 5985-00-831-5991 | |
| 50 | D | DIRECTIONAL COUPLER HP-H752D | 5985-00-814-4721 | |
| 51 | D | CRYSTAL DETECTOR HP-H424A-001 | 6625-00-861-2806 | |
| 52 | D | ATTENUATOR, FIXED 20 dB HP-8491 B/20 | 5985-00-454-6924 | |
| 53 | D | CRYSTAL DETECTOR MX-36711U (H P-420A) | 5865-00-982-5360 | |
| 54 | D | ADAPTER, WAVEGUIDE/COAX UG-1054/U (2 EA) | 5985-00-295-9824 | |
| 55 | D | ATTENUATOR, FIXED 10 dB CN-12851U | 5985-00-128-0195 | |
| 56 | D | VARIAC, 1 PHASE 400 HZ | | |
| 57 | D | VARIAC, 3 PHASE 400 HZ, PWERSTAT EN116-3 | | |
| 58 | F,H,D | ADAPTER, TEE UG-274C/U | 5935-00-926-7523 | |
| 59 | D | TEST FIXTURE (DEPOT), RECEIVER-TRANSMITTER TF 170283 | | |

| TOOL OR TEST EQUIPMENT REF CODE | MAINTENANCE CATEGORY | NOMENCLATURE | NATIONAL/ NATO STOCK NUMBER | TOOL NUMBER |
|---------------------------------|----------------------|---|-----------------------------|-------------|
| 60 | D | TEST FIXTURE (DEPOT), CONTROL-INDICATOR TF 170278 | | |
| 61 | D | TEST FIXTURE, ANTENNA SIMULATOR TF 180963 | | |
| 62 | D | TEST FIXTURE, RECEIVER-TRANSMITTER STIMULATOR TF 170225 | | |
| 63 | D | TEST FIXTURE, CONTROL-INDICATOR STIMULATOR TF 100232 | | |
| 64 | D | TEST FIXTURE, IF, LOG-LIN/LOG TF 164579 (TF148074 WITH TF176047) | | |
| 65 | D | TEST FIXTURE, IF, PRE-AMP/GAIN CONTROL TF 164578 (TF148074 WITH TF170238) | | |
| 66 | D | TEST FIXTURE, LOW VOLTAGE POWER SUPPLY TF 140647 | | |
| 67 | O,F,H,D | ADAPTER, CARD TEST, RCVR/XMTR 100212 (SEE NOTE G) | 5840-00-021-7060 | |
| 68 | O,F,H,D | ADAPTER, CARD TEST, CONT/IND 100251 (SEE NOTE G) | 5840-00-717-7502 | |
| 69 | D | CABLE EXTENDER, MODULATOR/CHARTER TF164196 | | |
| 70 | O,F,H,D | CLINOMETER, ANTENNA 102820 (SEE NOTE G) | 5840-00-065-5336 | |
| 71 | O,F,H,D | TELESCOPE 117846 (SEE NOTE G) | 6650-00-689-8270 | |

**TOOL AND TEST EQUIPMENT REQUIREMENTS FOR
RADAR SET AN/TPN-18A (CONT)**

| TOOL OR TEST EQUIPMENT REF CODE | MAINTENANCE CATEGORY | NOMENCLATURE | NATIONAL/ NATO STOCK NUMBER | TOOL NUMBER |
|---------------------------------------|-------------------------|---|-----------------------------------|----------------|
| 72 | O,F,H,D | EXTRACTOR, CIRCUIT CARD G500004S3 (SEE NOTE G) | | |
| 73 | D | CABLE EXTENDER, INDICATOR POWER SUPPLY 164586-1 | | |
| 74 | D | TEST FIXTURE, LAMP DRIVER TF140527 | | |
| 75 | D | CABLE EXTENDER, REMOTE SWITCH CONTROL 164588-1 | | |
| 76 | D | TEST FIXTURE, LO REGULATOR TF140612 | | |
| 77 | D | CABLE EXTENDER, POWER SUPPLY MONITOR 164589-1 | | |
| 78 | D | TEST FIXTURE, ELECTRONIC CONTROL AMPLIFIER TF170240 | | |
| 79 | F,H,D | CONVERTER PLUG-IN CV- 3059/U FOR CP-772A/U (USED WITH ITEM 19) OR TD-1225(V)1/U* | 6615-00-552-4991 | |
| 80 | O,F,H,D | HANDLE, RATCHET, 4-1/8" LONG, XCELITE 99-1-R | 5120-01-020-7751 | |
| 81 | O,F,H,D | HANDLE, RATCHET T", 1 X 3-318", XCELITE 994-R | 5120-01-010-5502 | |
| 82 | O,F,H,D | EXTENSION BLADE (ADDS 4"), XCELITE 99-X-10 | 5120-01-52-8991 | |
| 83 | O,F,H,D | EXTENSION BLADE (ADDS 7"), XCELITE 99-X-10 | 5120-00-056-3928 | |

| TOOL OR TEST EQUIPMENT REF CODE | MAINTENANCE CATEGORY | NOMENCLATURE | NATIONAL/ NATO STOCK NUMBER | TOOL NUMBER |
|---------------------------------------|-------------------------|---|-----------------------------------|----------------|
| 84 | O,F,H,D | SCREWDRIVER, ALLEN HEX, 1/16", XCELITE 99-21 | 5120-00-162-2217 | |
| 85 | O,F,H,D | SCREWDRIVER, ALLEN HEX, 5/64", XCELITE 99-22 | 5120-00-156-0975 | |
| 86 | O,F,H,D | SCREWDRIVER, ALLEN HEX, 31/32", XCELITE 99-23 | 5120-00-190-5756 | |
| 87 | O,F,H,D | SCREWDRIVER, ALLEN HEX, 1/8", XCELITE 99-24 | 5120-00-156-0978 | |
| 88 | O,F,H,D | SCREWDRIVER, ALLEN HEX, 5/32", XCELITE 99-25 | 5120-00-406-3181 | |
| 89 | O,F,H,D | SCREWDRIVER, ALLEN HEX, 3/16", XCELITE 99-26 | 5120-00-112-9333 | |
| 90 | D | DC POWER SUPPLY HP-6291 A** | 6625-00-179-7718 | |
| 91 | D | DC POWER SUPPLY HP-6282A* * | 6130-00-241-0960 | |
| 92 | D | DC POWER SUPPLY HP-6206B (PD-6547/U) | 6625-00-823-5359 | |
| 93 | D | AMMETER, DC MODEL 931-2902009 | 6625-01-037-9607 | |
| 94 | D | DIRECTIONAL COUPLER, 20 dB (COAXIAL) H P-779D | 5985-00-490-2834 | |
| 95 | D | DIRECTIONAL COUPLER, 10 dB (COAXIAL) (99899) 3293-1 | 5985-01-036-1240 | |
| 96 | D | ELECTROSTATIC VOLTMETER ME-147/U | 6625-00-557-5672 | |

**TOOL AND TEST EQUIPMENT REQUIREMENTS FOR
RADAR SET AN/TPN-18A (CONT)**

| TOOL OR TEST EQUIPMENT REF CODE | MAINTENANCE CATEGORY | NOMENCLATURE | NATIONAL/ NATO STOCK NUMBER | TOOL NUMBER |
|---------------------------------------|-------------------------|--|-----------------------------------|----------------|
| 97 | D | NOISE SOURCE HP-343A (SG-978) OR TS-2436G* | 6625-00-793-1344 | |
| 98 | D | OSCILLOSCOPE OS-261/U* | 6625-00-127-0079 | |
| 99 | D | TERMINATION, WAVEGUIDE HP-H914A | 6625-00-879-3948 | |
| 100 | D | CONNECTOR, ADAPTER, BNC PLUGISMA JACK (16179) 3282-2240-00 | | |
| 101 | D | CONNECTOR, ADAPTER, BNC JACK/SMA JACK (16179) 3280-2240-00 | | |
| 102 | D | IF STRIP TEST COVER (24930) GS16-402-4 (4 EA) | | |
| 103 | D | GENERATOR, DIGITAL DELAY, MODEL 7010 (17778) | | |
| 104 | D | POWER SUPPLY, HV, FLUKE MODEL 415B (89536) | 6130-00-224-2059 | |
| 105 | F,H,D | VOLTMETER, ELECTRONIC ME-26/U OR ME-303A/U* | 6625-00-913-9781 | |
| | | *ACC PIL ITEM | | |
| | | **PP-2309()IU SUB- STITUTE AVAILABLE FIRST QTR CY 1981 | | |

| TOOL OR TEST EQUIPMENT REF CODE | MAINTENANCE CATEGORY | NOMENCLATURE | NATIONAL/ NATO STOCK NUMBER | TOOL NUMBER |
|---------------------------------------|-------------------------|---|-----------------------------------|----------------|
| | | ADDITIONAL ACC PIL ITEMS AVAILABLE AT EACH SRA IN SUPPORT OF LANDING CONTROL CENTRAL ANITSQ-71 B AN/TPM-25A AN/USM-298 AN/USM-423 SG-1112(V)1/U TF-2300A (ME-505) TS-1836D/U TV-7()/U TS-147F/UP | | |

Section IV REMARKS

| REFERENCE CODE | REMARKS |
|----------------|--|
| A | Includes operational alinement. |
| B | Using bite at direct support. |
| C | Limited repair - fuses, lamps, lenses, filters. |
| D | Alinements requiring only multimeter TS-352B/U. |
| E | Requires direct support alinement. |
| F | Direct support - replaces pluck-out cards; general support - limited hard-wiring repairs. |
| G | This item of special function (maintenance or operation) has been and remains part of radar set AN/TPN-18, |

Section IV REMARKS (CONT)

| REFERENCE CODE | REMARKS |
|----------------|---|
| H | <p>10-35° actuator and cams in antenna drive may be adjusted by "O" level.</p> <p>Switch settings may be set by "0" level.</p> |
| J | <p>Required at "O" level when radar set is located at site above 6000 feet elevation.</p> <p style="text-align: center;">GENERAL NOTE</p> <p>Depot repair allocations for group number items 0107 through 05 only will have piece parts available by requisition for authorized AMSF/SRA's. Repairs may be accomplished by each AMSF/SRA within the capabilities and facilities available.</p> <p>AUTHORIZED SPECIAL REPAIR ACTIVITIES (SRA)</p> <ol style="list-style-type: none"> 1. AREA MAINTENANCE AND SUPPLY FACILITY, EUROPE, MANNHEIM, GERMANY 2. AREA MAINTENANCE AND SUPPLY FACILITY, OKINAWA, ZUKERAN, JAPAN 3. THE AIR TRAFFIC CONTROL AREA MAINTENANCE ACTIVITY, FORT RUCKER, ALABAMA |

APPENDIX C**COMPONENTS OF END ITEM AND BASIC ISSUE ITEMS LISTS****Section I INTRODUCTION****C-1. SCOPE.**

This appendix lists components of end item and basic Issue items for the Radar Set ANITPN-18A to help you inventory items required for safe and efficient operation.

C-2. GENERAL.

The Components of End Item and Basic Issue Items Lists are divided into the following sections:

a. Section II, Components of End Item. This listing is for informational purposes only, and is not authorization to requisition replacements. These items are part of the end item, but are removed and separately packaged for transportation or shipment. As part of the end item, these items must be with the end item whenever it is issued or transferred between property accounts. Illustrations are furnished to assist you in identifying the items.

b. Section II, Basic Issue Items. These are the minimum essential items required to place the Radar Set AN/TPN-18A in operation, to operate it, and to perform emergency repairs. Although shipped separately packaged, BII must be with the Radar Set AN/TPN-18A during operation and whenever it is transferred between property accounts. The illustrations will assist you with hard-to- identify items. This manual is your authority to request/requisition replacement BII, based on TOE/MTOE authorization of the end item.

C-3. EXPLANATION OF COLUMNS.

The following provides an explanation of columns found in the tabular listings:

a. Column 1, Illustration Number (Illus No.). This column indicates the number of the illustration in which the item is shown.

b. Column 2, National Stock Number. Indicates the National stock number assigned to the item. The national stock numbers in section III will be used for requisitioning basic issue items.

c. Column 3, Description. Indicates the federal item name and, if required, a minimum description to identify and locate the item. The last line for each item indicates the FSCM (in parentheses) followed by the part number.

If item needed differs for different models of this equipment, the model is shown under the "Usable On Code" heading in this column.

d. Column 4, Unit of Measure (U/M). Indicates the measure used in performing the actual operational/maintenance function. This measure is expressed by a two-character alphabetical abbreviation (ea, in., pr).

e. Column 5, Quantity Required (Qty Req'd). Indicates the quantity of the item authorized to be used with/on the equipment.

Section II COMPONENTS OF END ITEM

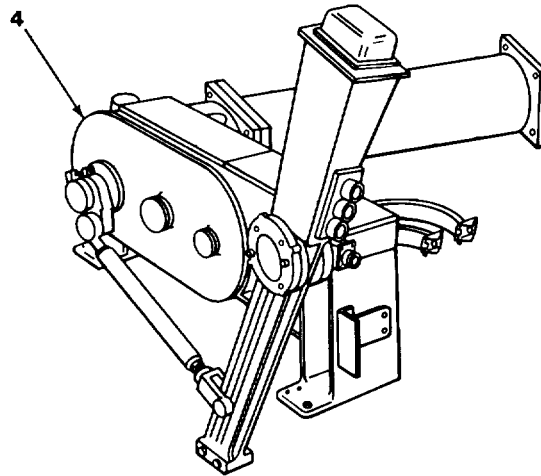
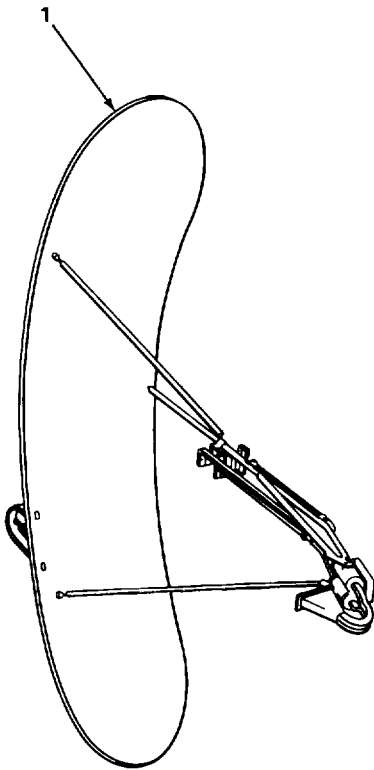
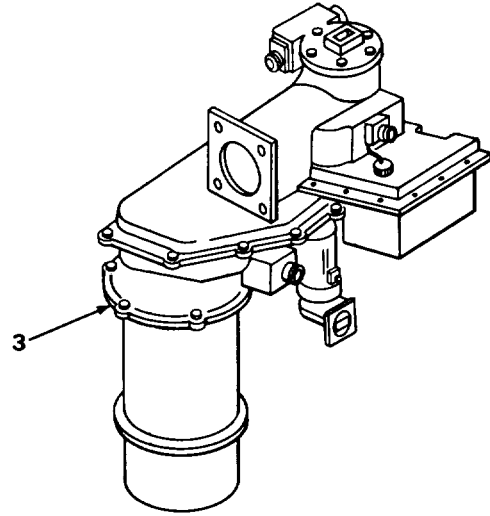
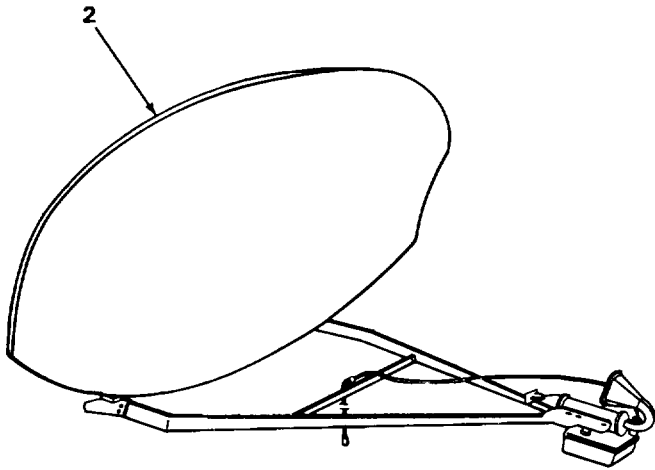

COMPONENTS OF END ITEM (CONT)

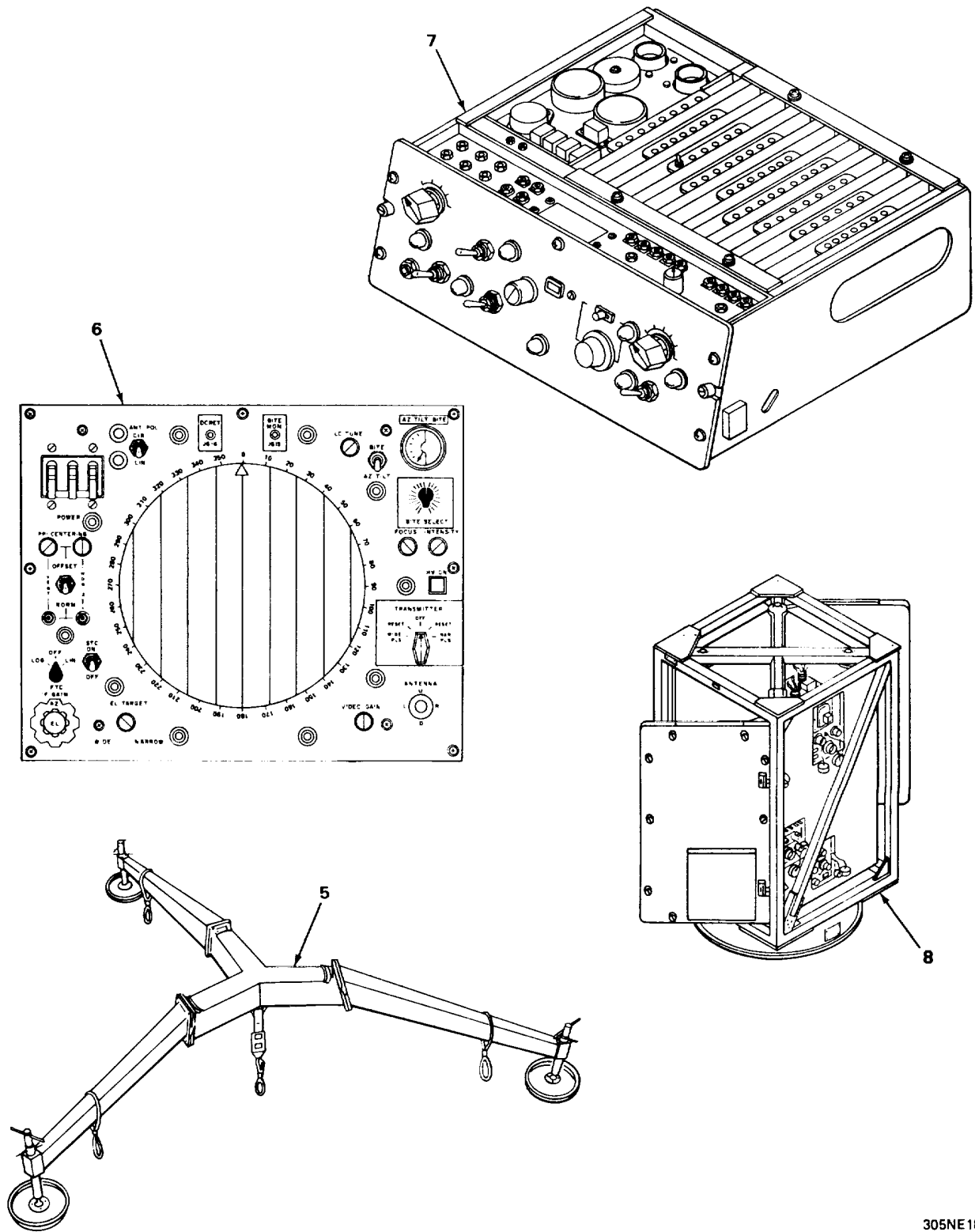

305NE 180

COMPONENTS OF END ITEM (CONT)

| (1) ILLUS NUMBER | (2) NATIONAL STOCK NUMBER | (3) DESCRIPTION (FSCM) AND PART NUMBER | (4) U/M | (5) QTY REQ'D |
|------------------------|---------------------------------|--|------------|---------------------|
| 1 | 5840-00-082-3725 | ELEVATION ANTENNA AS-1291/ TPN-8 (24930) 102625 | EA | 1 |
| 2 | 5840-00-082-3726 | AZIMUTH ANTENNA AS-1292/ TPN-8 (24930) 100226 | EA | 1 |
| 3 | 5840-01-070-4471 | AZIMUTH ANTENNA DRIVE TG-230/TPN-18 (24930) 170293-1 | EA | 1 |
| 4 | 5840-01-072-3154 | ELEVATION ANTENNA DRIVE TG-231/TPN-18 (24930) 170294-1 | EA | 1 |
| 5 | 5840-00-078-5621 | ANTENNA PEDESTAL AB1738/ TPN-8 (24930) 100202 | EA | 1 |
| 6 | 5840-01-071-7486 | CONTROL-INDICATOR C-6988A/ TPN-18 (24930) 170278-1 | EA | 2 |
| 7 | 5840-01-071-7487 | PULSE GENERATOR 0-16901 TPN-18 (24930) 1702791 | EA | 2 |
| 8 | 5840-01-069-4415 | RADAR RECEIVER-TRANSMITTER RT-1172/TPN-18 (24930) 170283-1 | EA | 1 |

Section III BASIC ISSUE ITEMS

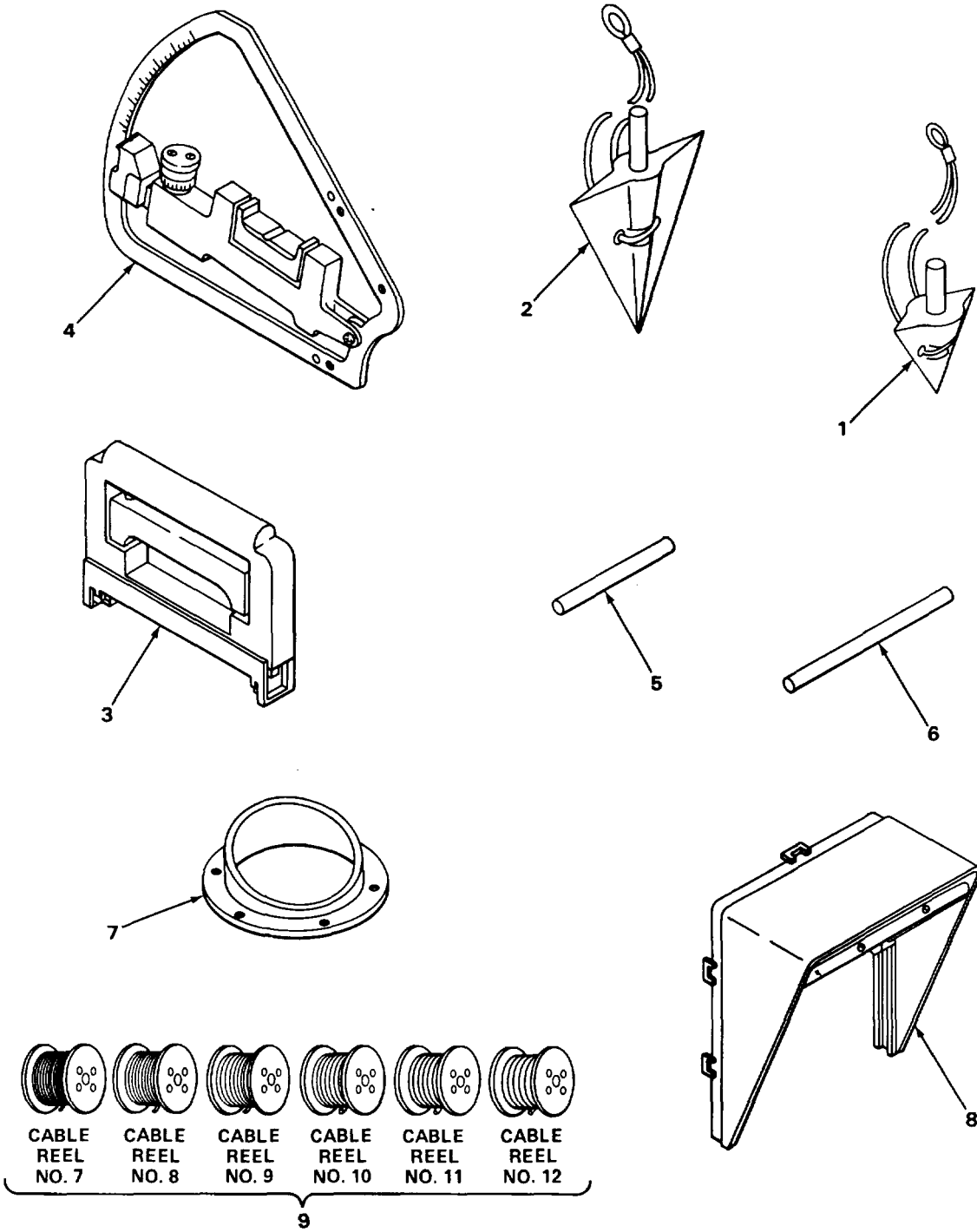

BASIC ISSUE ITEMS (CONT)

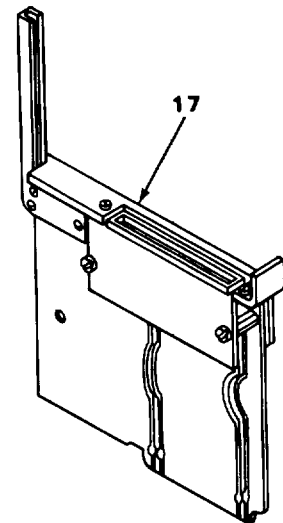
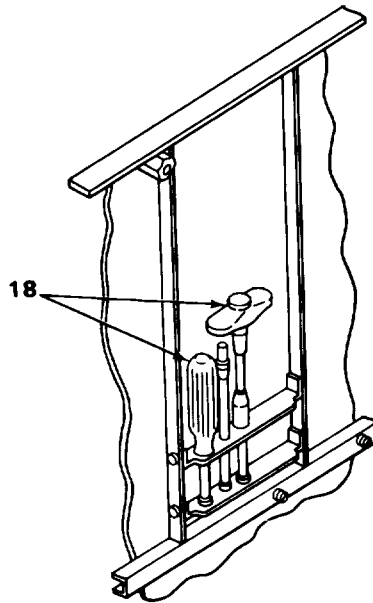
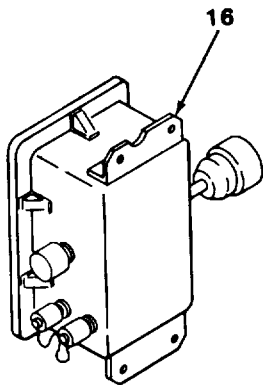
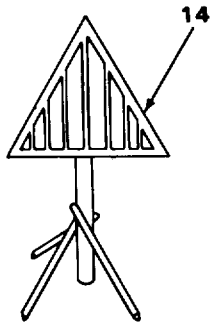
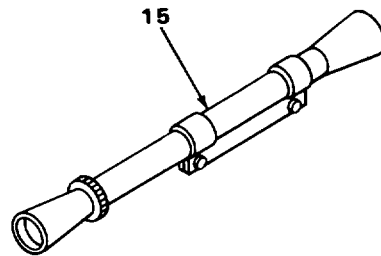
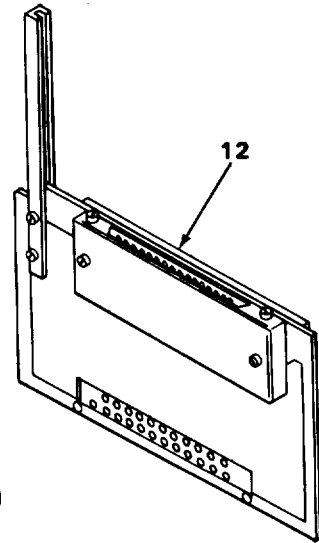
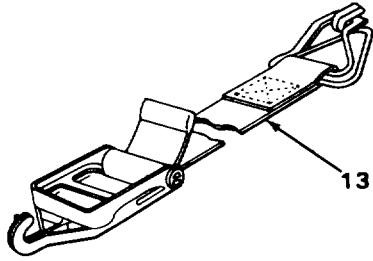
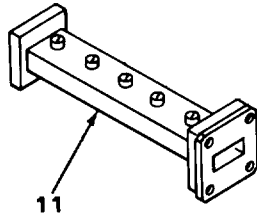
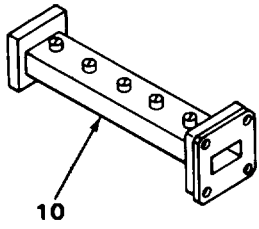

BASIC ISSUE ITEMS (CONT)

| (1) ILLUS NUMBER | (2) NATIONAL STOCK NUMBER | (3) DESCRIPTION (FSCM) AND PART NUMBER | (4) U/M | (5) QTY REQ'D |
|------------------------|---------------------------------|--|------------|---------------------|
| 1 | 4030-00-056-7461 | ANCHOR, 3-INCH (MALLEABLE) (24930) G400054-1 | EA | 3 |
| 2 | 4030-00-889-2364 | ANCHOR, 6-INCH (MALLEABLE) (24930) G400054-2 | EA | 1 |
| 3 | 5999-01-056-0860 | CARD EXTRACTOR (24930) G50000453 | EA | 1 |
| 4 | 5840-00-065-5336 | CLINOMETER, ANTENNA (24930) 102820 | EA | 1 |
| 5 | 5340-00-066-4052 | DRIVING ROD (3 FEET) (24930) G-5000001-1 | EA | 1 |
| 6 | 5340-00-066-4192 | DRIVING ROD (6 FEET) (24930) G-500001-2 | EA | 1 |
| 7 | 6240-00-713-0130 | INDICATOR, RAIN DEFLECTORS (24930) 103122 | EA | 2 |
| 8 | 5840-00-433-2359 | INDICATOR, RAIN SHIELDS (24930) 112449 | EA | 2 |
| 9 | 5930-00-331-4062 | INTERCONNECTING CABLE INSTALLATION (CABLES AND REELS) (24930) 180975-1 | EA | 1 |
| 10 | 5915-01-073-9060 | PRESELECTOR FILTERS (PAIR) (24930)139962-2 | EA | 1 |
| 11 | 5915-01-073-9061 | PRESELECTOR FILTERS (PAIR) (24930) 139962-3 | EA | 1 |
| 12 | 5840-00-717-7502 | PULSE GENERATOR TEST ADAPTER (24930) 100251 | EA | 1 |
| 13 | 5340-00-065-5476 | RATCHET STRAP (70128) 3118101A030 | EA | 1 |
| 14 | 5840-01-G01-5238 | RADAR TARGET SIMULATOR | EA | 3 |
| 15 | 6650-00-689-8270 | SIGHTING SCOPE (24930) 117846 | EA | 1 |

BASIC ISSUE ITEMS (CONT)

| (1) ILLUS NUMBER | (2) NATIONAL STOCK NUMBER | (3) DESCRIPTION (FSCM) AND PART NUMBER | (4) U/M | (5) QTY REQ'D |
|------------------------|---------------------------------|---|------------|---------------------|
| 16 | 5840-01-069-4221 | SIGNAL MONITOR SELECTOR SA-2035/TPN-18 (24930) 139997-1 | EA | 1 |
| | | TECHNICAL MANUAL TM 11-5840-281-12-1 | EA | 2 |
| 17 | 5840-00-021-7060 | TEST ADAPTER, CARD (24930)100212 | EA | 1 |
| 18 | 5120-0152-8991 | WRENCH SET, Consisting of: | EA | 1 |
| | 5120-00-152-8991 | EXTENSION BLADE (4-INCH) (96508) 99-X-5 | EA | 1 |
| | 5120-00-560-3928 | EXTENSION BLADE (7-INCH) (96508) 99-X-10 | EA | 1 |
| | 5120-01-020-7751 | HANDLE, RATCHET (96508) 99-1-R | EA | 1 |
| | 5120-01-010-5502 | HANDLE, RATCHET (T) (96508) 99-4-R | EA | 1 |
| | 5120-00-162-2217 | SCREWDRIVER, ALLEN HEX (1/16-INCH) (96508) 99-21 | EA | 1 |
| | 5120-00-156-0975 | SCREWDRIVER, ALLEN HEX (5/164-INCH) (96508) 99-22 | EA | 1 |
| | 5120-00-190-5756 | SCREWDRIVER, ALLEN HEX (3/32-INCH) (96508) 99-23 | EA | 1 |
| | 5120-00-156-0978 | SCREWDRIVER, ALLEN HEX (1/8-INCH) (96508) 9924 | EA | 1 |
| | 5120-00-406-3181 | SCREWDRIVER, ALLEN HEX (5/132-INCH) (96508) 99-25 | EA | 1 |
| | 5120-00-112-9333 | SCREWDRIVER, ALLEN HEX (3/16-INCH) (96508) 99-26 | EA | 1 |

APPENDIX D

ADDITIONAL AUTHORIZATION LIST

Section I INTRODUCTION

D-1. SCOPE.

This appendix lists additional items you are authorized for the support of the radar set.

D-2. GENERAL.

This list identifies items that do not have to accompany the terminal set and that do not have to be turned in with it. These items are all authorized to you by CTA, MTOE, TDA, or JTA.

D3. EXPLANATION OF LISTING.

National stock numbers, descriptions, and quantities are provided to help you identify and request the additional items you require to support this equipment. The items are listed in alphabetical sequence by item name, under the type document (i.e. CTA, MTOE, TDA, or JTA) which authorizes the items to you. If item required differs for different models of this equipment, the model is shown under the "Usable On" heading in the description column.

Section II ADDITIONAL AUTHORIZATION LIST

| (1) ILLUS NUMBER | (2) NATIONAL STOCK NUMBER | (3) DESCRIPTION (FSCM) AND PART NUMBER | (4) U/M | (5) QTY REQ'D |
|------------------------|---------------------------------|---|------------|---------------------|
| | 6115-00-937-8468 | POWER UNIT PU-678/G (97403) | EA | 1 |

NOTE

Any available model of the PU-678/G may be used. NSN cited is for the currently available model for ordering purposes.

D-1/(D-2 blank)

APPENDIX E

EXPENDABLE SUPPLIES AND MATERIALS LIST

Section I INTRODUCTION

E-1. SCOPE.

This appendix lists expendable supplies and materials you will need to operate and maintain the Radar Set AN/TPN-18A. These items are authorized to you by CTA 50-970, Expendable Items (except medical, class V, repair parts, and heraldic items).

E-2. EXPLANATION OF COLUMNS.

a. Column 1, Item Number. This number is assigned to the entry in the listing and is referenced in the narrative instructions to identify the material (eg, use cleaning compound, item 1, appendix E).

b. Column 2, Level. This column identifies the lowest level of maintenance that requires the listed item.

C - Operator/Crew

O - Organizational

F - Direct Support

c. Column 3, National Stock Number. This is the National stock number assigned to the item; use it to request or requisition the item.

d. Column 4, Description. Indicates the federal item name and, if required, a description to identify the item. The last line for each item indicates the Federal Supply Code for Manufacturer (FSCM) in parentheses, followed by the part number.

e. Column 5, Unit of Measure (U/M). Indicates the measure used in performing the actual maintenance function. This measure is expressed by a two-character alphabetical abbreviation (eg, ea, in., pr). If the unit of measure differs from the unit of issue, requisition the lowest unit of issue that will satisfy your requirements.

Section II EXPENDABLE SUPPLIES AND MATERIALS LIST

| (1) ITEM NUMBER | (2) LEVEL | (3) NATIONAL STOCK NUMBER | (4) DESCRIPTION | (5) U/M |
|-----------------------|--------------|---------------------------------|---|------------|
| 1 | C,O | 7510-00-550-8448 | BRUSH, SOFT-BRISTLE (PART OF TOOL KIT) | EA |
| 2 | C,O | 8305-00-267-3015 | CLOTH, LINT-FREE (PART OF TOOL KIT) | LB |
| 3 | O | 5350-00-192-5052 | CROCUS CLOTH | PG |
| 4 | O | | GREASE, POLAR START DN600 | GALE-1 |

Section II EXPENDABLE SUPPLIES AND MATERIALS LIST (CONT)

| (1) ITEM NUMBER | (2) LEVEL | (3) NATIONAL STOCK NUMBER | (4) DESCRIPTION | (5) U/M |
|-----------------------|--------------|---------------------------------|---|------------|
| 5 | O | 9150-00-985-7246 | GREASE, MIL-G-23827 | QT |
| 6 | O | 9150-00-223-4129 | OIL, LUBRICATING, GENERAL PURPOSE PRESERVATIVE MIL-L-6085A | QT |
| 7 | O | 5350 235-0124 | SANDPAPER, FINE, 105 GRIT | PG |
| 8 | C,O | 6850-00-105-3084 | TRICHLOROTRIFLUOROETHANE | QT |

GLOSSARY

| | |
|---------------------------------|--|
| Centerline of runway (clr) | The longitudinal center of the runway. |
| Courseline | An imaginary extension of the clr that represents the approach path for a landing aircraft. |
| Cursor | Electronically generated lines on both azimuth and elevation beta displays that are adjusted to represent the desired glidepath and courseline. |
| Distance to touchdown | The distance from td point to the radar set group. |
| Glidepath | The angle formed by the intercept of the aircraft descent path and horizontal (0-degree reference). |
| Ground angle | Angle formed (at radar site) by line representing horizontal and line from radar site to td point. Ground angle is positive when elevation of td point is higher than radar site, negative when td point is lower. |
| Offset distance | The distance of a perpendicular line from the clr to the radar set group. |
| Operating site | Physical location of the control-indicator groups. |
| Radar site | Physical location of the receiver-transmitter group. |
| Right-of-runway, left-of-runway | The side of runway on which the radar set group is located, as seen by the pilot of a landing aircraft. |
| Runway parallel line (rpl) | An Imaginary line extending from the radar set group, parallel to the clr. |
| Touchdown (td) | The point at which an aircraft will touch the runway when following the predetermined glidepath and courseline. |

Glossary 1/(Glossary 2 blank)

INDEX

| Subject | Page |
|--|-------|
| A | |
| Accessibility | 4-3 |
| Additional authorization list | D-1 |
| Administrative storage | 1-2 |
| Administrative storage | 4-169 |
| Shipping drum no. 5 | 4-173 |
| Shipping drum no. 6 | 4-169 |
| Shipping frame no. 1 | 4-170 |
| Shipping frame no. 2 | 4-172 |
| Air filter cleaning and servicing | 4-133 |
| Antenna pedestal assembly | 4-22 |
| Antenna pedestal installation | 4-28 |
| Antijamming procedures | 2-39 |
| Applicable regulations | 4-3 |
| Assembly and preparation for use | 2-10 |
| Azimuth antenna assembly | 4-24 |
| Azimuth antenna drive and yoke assembly installation | 4-32 |
| Azimuth antenna drive assembly | 4-23 |
| Azimuth antenna installation | 4-33 |
| AZ TILT/BITE meter alinement | 4-81 |
| C | |
| Checking installation | 4-70 |
| Checking the 10- to 35-degree actuator | 4-76 |
| Checking unpacked equipment | 4-21 |
| Circuit alinement | 4-85 |
| Cursor alinement | 4-92 |
| Determining angle volts setting for azimuth offset angle | 4-91 |
| Determining elevation cursor alinement angle | 4-89 |
| Location of target simulators on radar displays | 487 |
| PPI display adjustment | 4-100 |
| PPI orientation | 4-102 |
| Precision display adjustments | 4-85 |
| Clinometer installation | 4-44 |
| Components of end item and basic issue items list | C-1 |
| Component principles of operation | 1-17 |
| Azimuth and elevation antenna drives | 1-19 |
| Azimuth and elevation antennas | 1-18 |
| Control-indicator | 1-21 |
| Dual beta display | 1-22 |
| Height finder display | 1-23 |
| Indicator power supply | 1-25 |
| Off-centered display | 1-21 |
| PPI display | 1-21 |
| Pulse generator | 1-24 |
| Receiver-transmitter | 1-17 |
| Consolidated index of Army publications and blank forms | 1-1 |

INDEX

| Subject | Page |
|--|-------|
| C (CONT) | |
| Control-indicator, description of maintenance controls, indicators, and switches | 4-122 |
| Control-indicator disassembly | 4-156 |
| Control-indicator, functions of controls, switches, and indicators | 2-1 |
| Control-indicator power supply adjustment | 4-140 |
| Control-indicator voltages test | 4-150 |
| Control knob replacement | 4-135 |
| Countermeasures, reporting and recording..... | 2-39 |
| Cursor alinement | 4-92 |
| D | |
| Dehydrator cartridge replacement | 4-133 |
| Description and use of operator's controls and indicators..... | 2-1 |
| Description of maintenance controls, Indicators, and switches | 4-117 |
| Control-indicator | 4-122 |
| Pulse generator | 4-118 |
| Receiver-transmitter | 4-125 |
| Destruction of Army materiel to prevent enemy use | 1-2 |
| Determining angle volts setting for azimuth offset angle | 4-91 |
| Determining elevation cursor alinement angle | 489 |
| Disassembly | 4-155 |
| Control-indicator disassembly | 4-156 |
| Interconnecting cable disconnection | 4-155 |
| Radar set group disassembly | 4-156 |
| Drum no. 5, unpacking | 4-20 |
| Drum no. 6, unpacking | 4-20 |
| E | |
| Electronic filters performance test | 4-149 |
| Elevation antenna assembly | 4-26 |
| Elevation antenna drive Installation..... | 4-31 |
| Elevation antenna installation | 4-35 |
| Elevation drive motor check..... | 4-152 |
| Elevation electronic filter alinement | 4-141 |
| Elevation servo and azimuth scan protractor check..... | 4-151 |
| Elevation servo blanking alinement | 4-84 |
| Elevation yoke assembly installation | 4-34 |
| Emergency procedures | 2-36 |
| All precision modes fail | 2-37 |
| Range fails | 2-37 |
| 10-degree elevation fails..... | 2-37 |
| Emergency shutdown | 2-34 |
| Equipment characteristics, capabilities, and features..... | 1-3 |
| Equipment component location | 4-8 |
| Equipment configuration | 1-12 |
| Equipment data | 1-8 |

INDEX

Subject Page

E (CONT)

| | |
|---|------|
| Equipment interlocks | 4-73 |
| Equipment siting limits | 4-4 |
| Equipment siting procedures | 4-9 |
| Expendable supplies and materials list..... | E-1 |

F

| | |
|---|-------|
| Fixed coil amplifier adjustment..... | 4-142 |
| Functions of controls, switches, and indicators | 2-1 |
| Control-indicator..... | 2-6 |
| Pulse generator | 2-4 |
| Receiver-transmitter | 2-1 |

G

| | |
|----------------------------------|------------|
| Glossary..... | Glossary 1 |
| Ground angle determination | 4-53 |

H

| | |
|-------------------------------|------|
| Height finder operation | 2-29 |
|-------------------------------|------|

I

| | |
|---|-------|
| IFF mode | 2-32 |
| IFF operation | 2-31 |
| IFF mode | 2-32 |
| Precision mode..... | 2-32 |
| Search mode..... | 2-31 |
| Simultaneous mode..... | 2-32 |
| Video clutter | 2-32 |
| Indicator rain shields and deflectors installation..... | 4-45 |
| Initial turn-on procedure | 4-76 |
| Installing preselector filters..... | 4-77 |
| Interconnecting cable disconnection | 4-155 |
| Interconnecting cable identification | 446 |
| Interconnecting cable Installation | 4-48 |
| Interconnecting cables | 4-46 |
| Interconnecting cable identification | 446 |
| Interconnecting cable Installation | 4-48 |
| Intermediate storage | 4-174 |

J

| | |
|--|------|
| Jamming and ECM procedures | 2-37 |
| Antijamming procedures | 2-39 |
| Countermeasures, reporting and recording | 2-39 |

INDEX

| Subject | Page |
|---|-------|
| J (CONT) | |
| Jamming and ECM procedures (Cont) | |
| Reflected jamming | 2-38 |
| Transmission jamming..... | 2-38 |
| L | |
| Line-of-site obstructions | 4-3 |
| Local control monitor test | 4-144 |
| Location and description of major components..... | 1-3 |
| Azimuth antenna..... | 1-3 |
| Azimuth antenna drive..... | 1-4 |
| Base pedestal..... | 1-5 |
| Control-indicator group | 1-6 |
| Elevation antenna..... | 1-4 |
| Elevation antenna drive | 1-5 |
| Indicator power supply | 1-8 |
| Receiver-transmitter group | 1-6 |
| Location of target simulators on range displays | 4-87 |
| Low-voltage power supply test..... | 4-143 |
| Lubrication | 4-154 |
| M | |
| Maintenance allocation | B-1 |
| Maintenance allocation chart for ANITPN-18A | B-3 |
| Maintenance forms, records, and reports..... | 1-1 |
| Method four, siting of target simulators..... | 4-62 |
| Method one, siting of target simulators | 4-55 |
| Method three, siting of target simulators | 4-58 |
| Method two, siting of target simulators | 4-56 |
| N | |
| Nomenclature cross-reference list | 1-2 |
| Normal shutdown | 2-33 |
| O | |
| Operating instructions | 2-1 |
| Operation under unusual conditions | 2-34 |
| Emergency procedures..... | 2-36 |
| General | 2-34 |
| Jamming and ECM procedures..... | 2-38 |
| Operation under usual conditions | 2-10 |
| Assembly and preparation for use | 2-10 |
| Emergency shutdown | 2-34 |
| Height finder operation | 2-29 |
| IFF operation | 2-31 |

INDEX

| Subject | Page |
|--|-------|
| O (CONT) | |
| Normal shutdown | 2-33 |
| Precision approach operation..... | 2-25 |
| Preliminary control settings | 2-10 |
| Preliminary operating procedure | 2-13 |
| Search operation | 2-21 |
| Simultaneous mode operation | 2-29 |
| Standby condition | 2-32 |
| Operator maintenance | 3-1 |
| Operator maintenance procedures | 3-1 |
| Operator troubleshooting procedures | 3-1 |
| Operator maintenance procedures | 3-1 |
| Cleaning and inspection | 3-2 |
| Cursor alinement checks | 3-4 |
| Dehydrator cartridge inspection | 3-10 |
| Front panel and Indicator lamp | 3-20 |
| Fuse replacement | 3-21 |
| General | 3-2 |
| Operational check | 3-11 |
| Operator preventive maintenance checks and services | 2-8 |
| Operator's controls and indicators, description and use of | 2-1 |
| Operator troubleshooting procedures | 3-1 |
| Organizational maintenance | 4-1 |
| Organizational maintenance procedures | 4-117 |
| Organizational preventive maintenance checks and services (PMCS) | 4-103 |
| Organizational troubleshooting | 4-105 |
| Preparation for storage and shipment | 4-155 |
| Repair parts, special tools, TMDE, and support equipment | 4-1 |
| Service upon receipt | 4-1 |
| Organizational maintenance procedures | 4-117 |
| Air filter cleaning and servicing | 4-133 |
| Azimuth antenna scan adjustment | 4-143 |
| Azimuth electronic filter alinement | 4-142 |
| Control-indicator power supply adjustment..... | 4-140 |
| Control knob replacement..... | 4-135 |
| Dehydrator cartridge replacement | 4-133 |
| Description of maintenance controls, Indicators, and switches | 4-117 |
| Elevation electronic filter alinement | 4-141 |
| Fixed coil amplifier adjustment | 4-142 |
| General | 4-117 |
| Lubrication..... | 4-154 |
| Performance checks..... | 4-143 |
| Plug-In circuit card replacement | 4-137 |
| Receiver-transmitter low-voltage power supply replacement..... | 4-138 |
| Receiver-transmitter power supply adjustment..... | 4-139 |
| Touchup painting | 4-154 |
| Transmitter control panel lamp replacement | 4-136 |

INDEX

| Subject | Page |
|---|-------|
| O (CONT) | |
| Organizational preventive maintenance checks and services | 4-103 |
| General | 4-103 |
| Organizational preventive maintenance checks and services | 4-103 |
| Organizational troubleshooting | 4-105 |
| General | 4-105 |
| Symptom Index | 4-105 |
| Troubleshooting procedures..... | 4-106 |
| Orientation procedure | 4-68 |
| Orienting radar set group | 4-68 |
| P | |
| Performance tests | 4-143 |
| Control-indicator voltages test | 4-150 |
| Electronic filters performance test | 4-149 |
| Elevation drive motor check | 4-152 |
| Elevation servo and azimuth scan protractor check | 4-151 |
| Local control monitor test | 4-144 |
| Low-voltage power supply test..... | 4-143 |
| Precision scan mode check. | 4-152 |
| Transmitter high-voltage test | 4-153 |
| Plug-in circuit card replacement | 4-137 |
| PPI display adjustment..... | 4-100 |
| PPI orientation | 4-102 |
| Precision approach operation | 2-25 |
| Video clutter | 2-27 |
| Precision display adjustments | 4-85 |
| Precision mode | 2-32 |
| Precision mode | 2-32 |
| Precision scan mode check | 4-152 |
| Preliminary control settings | 2-10 |
| Control-indicators | 2-12 |
| Pulse generator units | 2-13 |
| Receiver-transmitter | 2-10 |
| Preliminary operating procedure..... | 2-14 |
| Control-indicators | 2-16 |
| Receiver-transmitter | 2-14 |
| Turn-on procedure | 2-14 |
| Preliminary servicing and adjustment..... | 4-68 |
| AZ TILTIBITE meter alinement..... | 4-81 |
| Checking Installation | 4-70 |
| Checking the 10- to 35-degree actuator | 4-76 |
| Elevation servo blanking alinement | 4-84 |
| Equipment interlocks | 4-73 |
| Initial turn-on procedure..... | 4-76 |
| Installing preselector filters | 4-77 |
| Orientation procedure | 468 |
| Orienting radar set group | 468 |

INDEX

| Subject | Page |
|--|-------|
| P (CONT) | |
| Preparation for storage and shipment | 4-155 |
| Administrative storage | 4-169 |
| Disassembly | 4-155 |
| General | 4-155 |
| Intermediate storage | 4-174 |
| Pulse generator, description of maintenance controls, indicators, and switches | 4-118 |
| Pulse generator, functions of controls, switches, and indicators | 2-4 |
| R | |
| Radar set assembly and installation instructions..... | 4-21 |
| Radar set group disassembly | 4-156 |
| Radar set group leveling | 4-52 |
| Receiver-transmitter, description of maintenance controls, indicators, and switches..... | 4-125 |
| Receiver-transmitter, functions of controls, switches, and indicators | 2-1 |
| Receiver-transmitter group Installation | 4-30 |
| Receiver-transmitter low-voltage power supply replacement | 4-138 |
| Receiver-transmitter power supply adjustment | 4-139 |
| References..... | A-1 |
| Reflected jamming | 2-38 |
| Repair parts, special tools, TMDE, and support equipment | 4-1 |
| Common tools and equipment | 4-1 |
| Repair parts | 4-1 |
| Special tools, TMDE, and support equipment | 4-1 |
| Repair parts, special tools, TMDE, and support equipment, organizational maintenance | 4-1 |
| Reporting Equipment Improvement Recommendations (EIR) | 1-2 |
| Runway siting configurations | 46 |
| S | |
| Safety, care, and handling | 1-14 |
| Search mode | 2-31 |
| Search operation..... | 2-21 |
| Centering video display | 2-23 |
| Offsetting video display | 2-23 |
| Reducing video clutter from ground returns and precipitation | 2-24 |
| Search mode | 2-21 |
| Video clutter | 2-23 |
| Service upon receipt | 4-1 |
| Antenna pedestal assembly | 4-22 |
| Antenna pedestal installation | 4-28 |
| Azimuth antenna assembly | 4-24 |
| Azimuth antenna drive and yoke assembly installation | 4-32 |
| Azimuth antenna installation | 4-33 |
| Azimuth antenna drive assembly | 4-23 |

INDEX

| Subject | Page |
|--|-------|
| S (CONT) | |
| Service upon receipt (Cont) | |
| Circuit alinement | 4-85 |
| Clinometer installation | 4-44 |
| Elevation antenna assembly | 4-26 |
| Elevation antenna drive Installation | 4-31 |
| Elevation antenna installation | 4-35 |
| Elevation yoke assembly installation | 4-34 |
| General | 4-2 |
| Ground angle determination | 4-53 |
| Indicator rain shields and deflectors installation | 4-45 |
| Interconnecting cables | 4-46 |
| Preliminary servicing and adjustment | 4-68 |
| Radar set assembly and installation instructions | 4-21 |
| Radar set group leveling | 4-52 |
| Receiver-transmitter group installation | 4-30 |
| Site and shelter requirements | 4-2 |
| Siting of target simulators | 4-55 |
| Siting scope Installation | 4-43 |
| Unpacking | 4-12 |
| Waveguides Installation | 4-36 |
| Shelter requirements | 4-11 |
| Shipping drum no. 5, administrative storage..... | 4-173 |
| Shipping drum no. 6, administrative storage..... | 4-169 |
| Shipping frame no.1, administrative storage..... | 4-170 |
| Shipping frame no.1, unpacking | 4-16 |
| Shipping frame no. 2, administrative storage | 4-172 |
| Shipping frame no. 2, unpacking | 4-18 |
| Simultaneous mode | 2-32 |
| Simultaneous mode operation | 2-29 |
| Site and shelter requirements..... | 4-2 |
| Accessibility | 4-3 |
| Applicable regulations | 4-3 |
| Equipment component location | 4-8 |
| Equipment siting limits..... | 4-4 |
| Equipment siting procedures | 4-9 |
| Line-of-site obstructions | 4-3 |
| Runway siting configurations | 4-6 |
| Shelter requirements | 4-11 |
| Terrain | 4-3 |
| Traffic patterns and flow | 4-3 |
| Siting of target simulators | 4-55 |
| Method four | 4-62 |
| Method one | 4-55 |
| Method three | 4-58 |
| Method two | 4-56 |
| Siting scope Installation | 4-43 |
| Standby condition..... | 2-32 |
| System principles of operation | 1-15 |

INDEX

| Subject | Page |
|---|-------|
| T | |
| Terrain | 4-3 |
| Tool and test equipment requirements for radar set AN/TPN-18A | B-17 |
| Touchup painting..... | 4-154 |
| Traffic patterns and flow | 4-3 |
| Transmission jamming | 2-38 |
| Transmitter control panel lamp replacement | 4-136 |
| Transmitter high-voltage test | 4-153 |
| Troubleshooting procedures, organizational | 4-106 |
| U | |
| Unpacking | 4-12 |
| Checking unpacked equipment..... | 4-21 |
| Drum no. 5 | 4-20 |
| Drum no. 6 | 4-20 |
| Shipping frame no. 1 | 4-16 |
| Shipping frame no. 2 | 4-18 |
| V | |
| Video clutter | 2-32 |
| W | |
| Waveguides Installation | 4-36 |

THE METRIC SYSTEM AND EQUIVALENTS

LINEAR MEASURE

1 Centimeter = 10 Millimeters = 0.01 Meters =
0.3937 Inches
1 Meter = 100 Centimeters = 1,000 Millimeters =
39.37 Inches
1 Kilometer = 1,000 Meters = 0.621 Miles

SQUARE MEASURE

1 Sq Centimeter = 100 Sq Millimeters = 0.155 Sq Inches
1 Sq Meter = 10,000 Sq Centimeters = 10.76 Sq Feet
1 Sq Kilometer = 1,000,000 Sq Meters = 0.386 Sq Miles

CUBIC MEASURE

1 Cu Centimeter = 1,000 Cu Millimeters = 0.06 Cu Inches
1 Cu Meter = 1,000,000 Cu Centimeters = 35.31 Cu Feet

LIQUID MEASURE

1 Milliliter = 0.001 Liters = 0.0338 Fluid Ounces
1 Liter = 1,000 Milliliters = 33.82 Fluid Ounces

TEMPERATURE

$5/9 (°F - 32) = °C$
212° Fahrenheit is equivalent to 100° Celsius
90° Fahrenheit is equivalent to 32.2° Celsius
32° Fahrenheit is equivalent to 0° Celsius
 $9/5 C° + 32 = F°$

WEIGHTS

1 Gram = 0.001 Kilograms = 1,000 Milligrams =
0.035 Ounces
1 Kilogram = 1,000 Grams = 2.2 lb.
1 Metric Ton = 1,000 Kilograms = 1 Megagram =
1.1 Short Tons

APPROXIMATE CONVERSION FACTORS

| TO CHANGE | TO | MULTIPLY BY |
|------------------------|------------------------|-------------|
| Inches | Centimeters | 2.540 |
| Feet | Meters | 0.305 |
| Yards | Meters | 0.914 |
| Miles | Kilometers | 1.609 |
| Square Inches | Square Centimeters | 6.451 |
| Square Feet | Square Meters | 0.093 |
| Square Yards | Square Meters | 0.836 |
| Square Miles | Square Kilometers | 2.590 |
| Acres | Square Hectometers | 0.405 |
| Cubic Feet | Cubic Meters | 0.028 |
| Cubic Yards | Cubic Meters | 0.765 |
| Fluid Ounces | Milliliters | 29.573 |
| Pints | Liters | 0.473 |
| Quarts | Liters | 0.946 |
| Gallons | Liters | 3.785 |
| Ounces | Grams | 28.349 |
| Pounds | Kilograms | 0.454 |
| Short Tons | Metric Tons | 0.907 |
| Pound-Feet | Newton-Meters | 1.356 |
| Pounds Per Square Inch | Kilopascals | 6.895 |
| Miles Per Gallon | Kilometers Per Liter | 0.425 |
| Miles Per Hour | Kilometers Per Hour | 1.609 |
| TO CHANGE | TO | MULTIPLY BY |
| Centimeters | Inches | 0.394 |
| Meters | Feet | 3.280 |
| Meters | Yards | 1.094 |
| Kilometers | Miles | 0.621 |
| Square Centimeters | Square Inches | 0.155 |
| Square Meters | Square Feet | 10.764 |
| Square Meters | Square Yards | 1.196 |
| Square Kilometers | Square Miles | 0.386 |
| Square Hectometers | Acres | 2.471 |
| Cubic Meters | Cubic Feet | 35.315 |
| Cubic Meters | Cubic Yards | 1.308 |
| Milliliters | Fluid Ounces | 0.034 |
| Liters | Pints | 2.113 |
| Liters | Quarts | 1.057 |
| Liters | Gallons | 0.264 |
| Grams | Ounces | 0.035 |
| Kilograms | Pounds | 2.205 |
| Metric Tons | Short Tons | 1.102 |
| Newton-Meters | Pound-Feet | 0.738 |
| Kilopascals | Pounds Per Square Inch | 0.145 |
| Kilometers Per Liter | Miles Per Gallon | 2.354 |
| Kilometers Per Hour | Miles Per Hour | 0.621 |

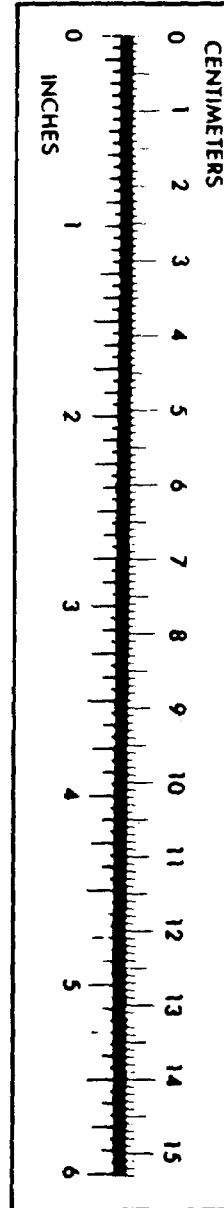

By Order of the Secretary of the Army:

JOHN A. WICKHAM JR.
General, United States Army

Official:

Chief of Staff

MILDRED E. HEDBERG
Brigadier General, United States Army
The Adjutant General

DISTRIBUTION:

To be distributed in accordance with DA Form 12-36 literature requirements for AN/TPN-18A.

*U.S. GOVERNMENT PRINTING OFFICE: 1990 261-872/20637

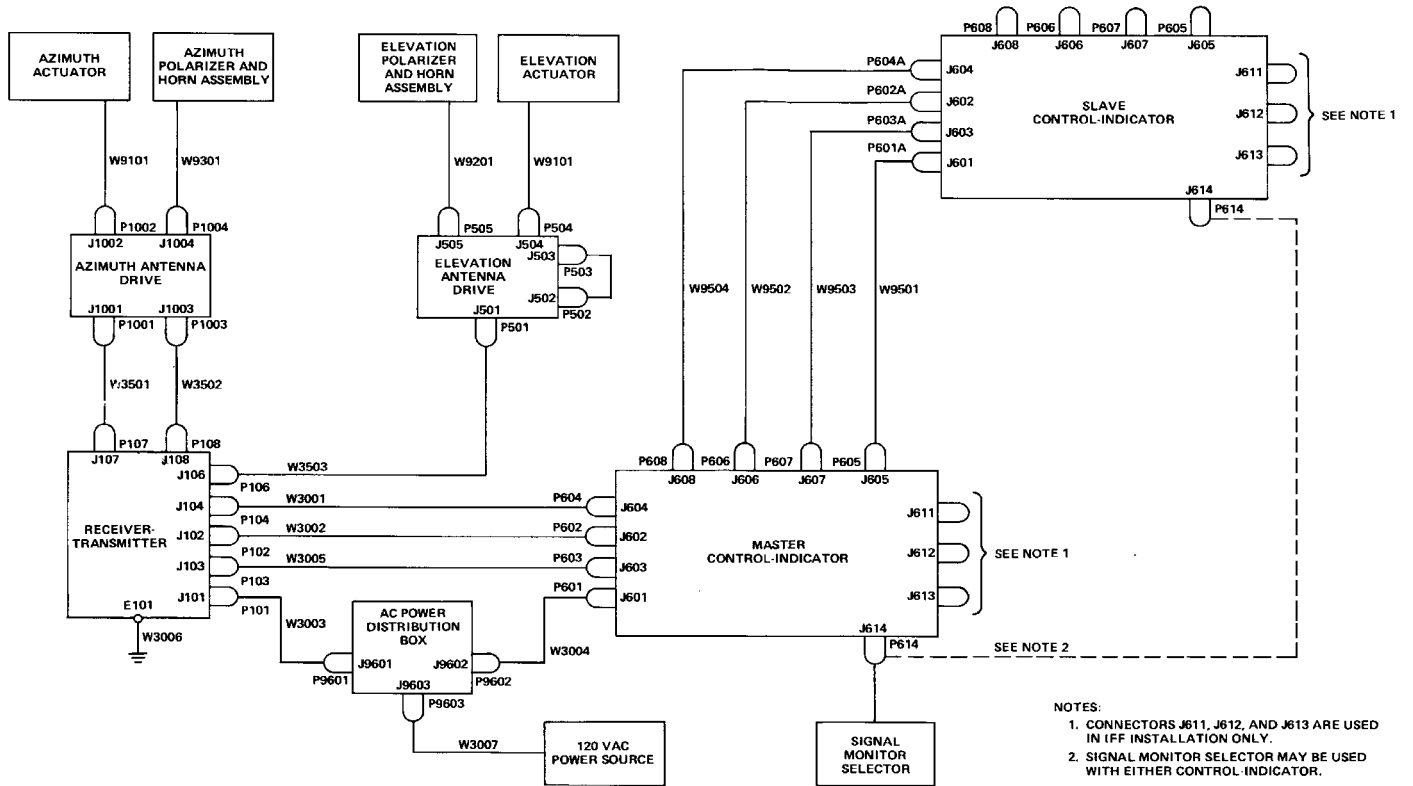

Figure FO-1. Interconnecting Cable Diagram.

☆U.S. GOVERNMENT PRINTING OFFICE: 1990 261-872/20637 FO-1

RECOMMENDED CHANGES TO EQUIPMENT TECHNICAL PUBLICATIONS



THEN... JOT DOWN THE DOPE ABOUT IT ON THIS FORM, CAREFULLY TEAR IT OUT, FOLD IT AND DROP IT IN THE MAIL!

SOMETHING WRONG WITH THIS PUBLICATION?

FROM: (PRINT YOUR UNIT'S COMPLETE ADDRESS)

DATE SENT

PUBLICATION NUMBER

TM 11-5825-270-10

PUBLICATION DATE

23 Jul 81

PUBLICATION TITLE

Radio Frequency R-2176/FRN

BE EXACT... PIN-POINT WHERE IT IS

| PAGE NO. | PARA-GRAPH | FIGURE NO. | TABLE NO. |
|----------|------------|------------|-----------|
| | | | |

IN THIS SPACE TELL WHAT IS WRONG AND WHAT SHOULD BE DONE ABOUT IT:

TEAR ALONG PERFORATED LINE

PRINTED NAME, GRADE OR TITLE, AND TELEPHONE NUMBER

SIGN HERE:

DA FORM 2028-2 JUL 79

PREVIOUS EDITIONS ARE OBSOLETE.

P.S.—IF YOUR OUTFIT WANTS TO KNOW ABOUT YOUR RECOMMENDATION MAKE A CARBON COPY OF THIS AND GIVE IT TO YOUR HEADQUARTERS.

